



Tursdale Technical Services Ltd
Unit N12B
Tursdale Business Park
Co. Durham
DH6 5PG
United Kingdom
Phone: +44 (0) 191 377 3398
Fax: +44 (0) 191 377 3357
info@tursdaletechnicalservices.co.uk
<http://www.industrial-needs.com/>

Manual PCE-008 air velocity meter



TABLE OF CONTENTS

1. FEATURES.....	1
2. SPECIFICATIONS.....	2
3. FRONT PANEL DESCRIPTION.....	6
4. GENERAL MEASURING PROCEDURE.....	8
4-1 Air velocity/Air temperature measurement.....	8
4-2 Air flow (CMM, CFM) measurement.....	9
4-3 Thermocouple (Type K/J) Thermometer measurement.....	10
4-4 Data Hold.....	11
4-5 Data Record (Max., Min. reading).....	11
4-6 Data Logger.....	12
5. ADVANCED ADJUSTMENT PROCEDURE.....	14
5-1 Check Memory Space.....	15
5-2 Clear Memory.....	15
5-3 Date/Time Setting.....	15
5-4 Sample Time Setting.....	16
5-5 Auto Power Off Default Setting.....	16
5-6 Temp. Unit Default Setting.....	16
5-7 Air Velocity Unit Default Setting.....	17
5-8 Air Flow Unit Default Setting.....	17
5-9 Area Size (Air Flow) Default Setting.....	17
5-10 Escape from the SETTING function.....	18
6. HOW TO SEND THE DATA OUT FROM THE METER.....	18
7. RS232 PC SERIAL INTERFACE.....	21
8. BATTERY REPLACEMENT.....	23
9. SYSTEM RESET.....	23
10. OPTIONAL ACCESSORIES.....	24

1. FEATURES

- * Air velocity : m/S, Ft/min, Km/h, Knots, Mile/h,
- * Air flow : CMM ($m^3/min.$) and CFM ($ft^3/min.$).
- * Air temperature ($^{\circ}C$, $^{\circ}F$)
- * Type K/ Type J thermocouple thermometer.
- * Real time data logger, build in clock (hour-min.-sec., year-month-date).
- * Auto or manual data record, 16,000 Data logger no.
- * Wide sampling time adjustment range from two seconds to 8 hours 59 minutes 59 seconds.
- * RS232 computer interface.
- * Can default auto power off or manual power off.
- * Can default the air velocity, air flow, Temp. unit.
- * Air flow measurement can set the area dimension.
- * Multi function with easy operation
- * Low-friction ball vane wheels make sure high accuracy in high & low velocities.
- * Metal vane, high reliability.
- * Large LCD with multiple display.
- * Data hold, record max. and min. reading.
- * Microcomputer circuit provides special function & offer high accuracy.
- * Air Temp. used thermistor sensor, fast response time.
- * Power by UM3 (1.5 V) x 4 batteries or DC 9V adapter.
- * RS232 PC serial interface.
- * Separate probe, easy for operation of different measurement environment.
- * Wide applications: use this anemometer to check air conditioning & heating systems, measure air velocities, wind temperature...etc.

2. SPECIFICATIONS

2-1 General Specifications

Circuit	Custom one-chip of microprocessor LSI circuit.	
Display	LCD size : 58 mm x 34 mm.	
Measurement Unit	<i>Air velocity:</i> m/S (meters per second) Km/h (kilometers per hour) Ft/min (feet per minute) Knots (nautical miles per hour) Mile/h (miles per hour)	
	<i>Air flow:</i> CMM (m ³ /min., cube meter per min.) CFM (m ³ /min., cube feet per min.)	
	<i>Air temperature:</i> °C, °F	
	<i>Type K/ Type J thermometer.</i> °C, °F	
Sampling Time of Data Logger	Manual	Push the data logger button once will save data one time. <i>@Set the sampling time to 0 second</i>
	Auto	2 sec to 8 hour 59 min. 59 sec.
Sensor Structure	<i>Air velocity & Air flow :</i> Conventional twisted van arm and low friction ball bearing design, vane use metal material.	
	<i>Air temperature :</i> Thermistor.	
	<i>Type K/ Type J thermometer.</i> Thermocouple	

Temperature Compensation	Automatic temp. compensation for the Type K/J thermometer.
Data Hold	Freeze the display reading.
Memory Recall	Maximum & Minimum value.
Sampling Time of display	Approx. 1 second.
Power off	Auto shut off saves battery life or manual off by push button.
Data Output	RS 232 PC serial interface.
Operating Temperature	0 to 50 °C.
Operating Humidity	Less than 80% R.H.
Power Supply <i>* main instrument</i>	DC 1,5 V battery (UM3) x 4 PCs, (Heavy duty type). DC 9V adapter input. <i>@ AC/DC power adapter is optional.</i>
Power Supply <i>* clock module</i>	DC 3V silver battery. Type : CR2032.
Power Current	Approx. DC 21.5 mA <i>@ Main instrument.</i> DC 27.5 mA. <i>@ Main instrument. + Anemometer probe.</i>
Weight	515 g/ 1.13 LB. <i>@ Battery is included.</i>
Dimension	<i>Main instrument :</i> 2000 x 762 x 368 mm <i>Anemometer sensor head :</i> Round, 72 mm Dia.
Accessories Included	Instruction manual..... 1 PC Anemometer probe.....1 PC DC 3V silver battery, CR2032.....1 PC Carrying case..... 1 PC

Optional Accessories	Type K thermocouple probe. AC to DC 9V adapter. RS232 cable, UPCB-02. Data Acquisition software, SW-U801-WIN. Data Logger software, SW-DL2005.
----------------------	--

2-2 Electrical Specifications (23± 5 °C)

Air velocity

Measurement	Range	Resolution	Accuracy
m/S	0.4 - 30.0 m/s	0.1 m/S	± (2%+0.2 m/S)
Km/h	1.4 - 126.0 km/h	0.1 Km/h	± (2%+0.8 Km/h)
Mile/h	0.9 - 78.3 mph	0.1 Mile/h	± (2%+0.4 Mile/h)
Knots	0.8 - 68.0 knots	0.1 Knots	± (2%+0.4 Knots)
Ft/min	79 - 6890 ft/min	1 Ft/min	± (2%+40 Ft/min)

Air flow

Measurement	Range	Resolution	Area
CMM (m ³ /min.)	0 to 54,000 m ³ /min.	0.001-1	0.001-30.0 m ³ /min.
CFM (ft ³ /min.)	0 to 1,908,300 ft ³ /min.	0.01-100	0.01-322.91 ft ³ /min.

Air temperature

Measuring Range	0 °C to 50 °C/32 °F to 122 °F
Resolution	0.1 °C/0.1 °F
Accuracy	± 0.8 °C/1.5 °F

Type K/J thermometer

Sensor Type	Resolution	Range	Accuracy
Type K	0.1 °C	-50.0 to 1300.0 °C	± (0.2 % + 0.5 °C)
		-50.1 to -100.0 °C	± (0.2 % + 1 °C)
	0.1 °F	-58.0 to 2372.0 °F	± (0.2 % + 1 °F)
		-58.1 to -148.0 °F	± (0.2 % + 1.8 °F)
Type J	0.1 °C	-100.0 to 1100.0 °C	± (0.2 % + 0.5 °C)
		-50.1 to -100.0 °C	± (0.2 % + 1 °C)
	0.1 °F	-58.0 to 2012.0 °F	± (0.2 % + 1 °F)
		-58.1 to -148.0 °F	± (0.2 % + 1.8 °F)

@Above specification tests under the environment RF Field Strength less than 3 V/M & frequency less than 30 MHz only.

3. FRONT PANEL DESCRIPTION

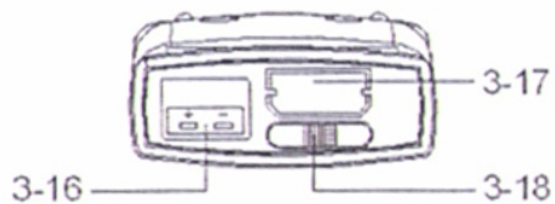
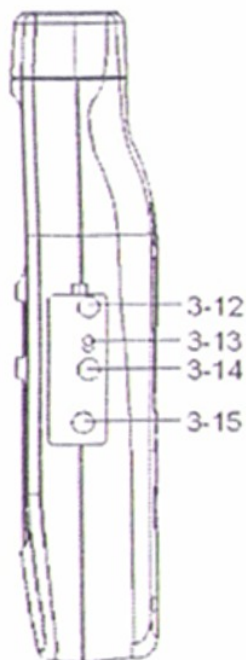
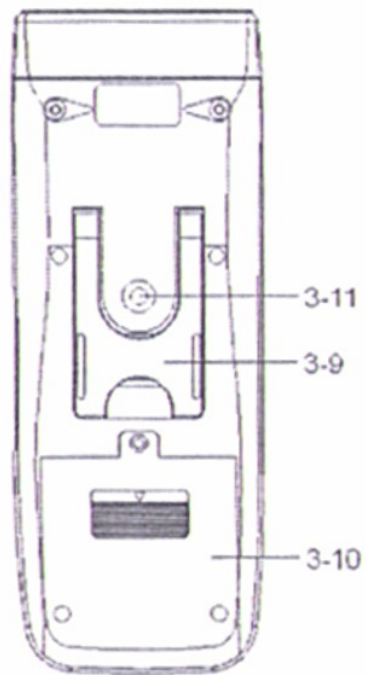
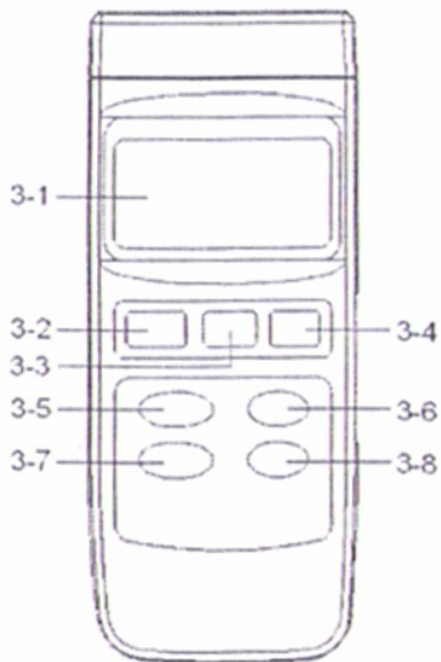

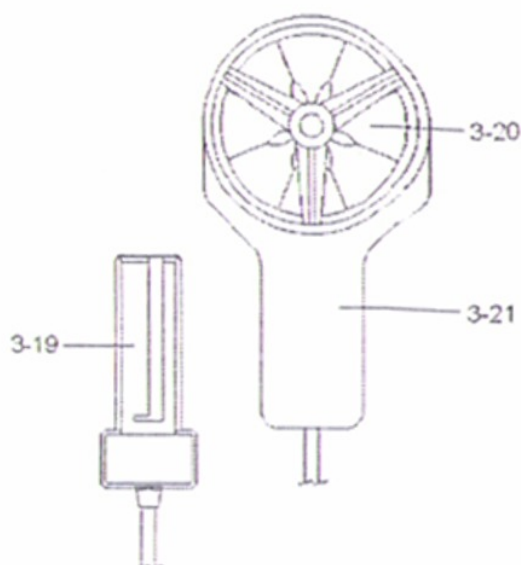

- 3-1 Display
- 3-2 Power Button
- 3-3 HOLD Button (ESC Button)
- 3-4 REC Button (Enter Button)
- 3-5 ▲ Up Button
- 3-6 Function Button (▼ Down Button)
- 3-7 Send Button (Clock Button)
- 3-8 SET Button (Logger Button)
- 3-9 Stand
- 3-10 Battery Compartment/Cover
- 3-11 Tripod Fix Nut
- 3-12 LCD Brightness Adjust VR
- 3-13 System Reset Switch
- 3-14 RS-232 Output Terminal
- 3-15 DC 9V Power Adapter Input Socket
- 3-16 Type K/J Probe Input Socket
- 3-17 Probe Input Socket
- 3-18 Probe Lock Switch (System On/Off Switch)
- 3-19 Probe Plug
- 3-20 Probe head (Anemometer vane & Temperature)
- 3-21 Probe handle

4. GENERAL MEASURING PROCEDURE

The meter default value are following :

- * The air velocity unit is m/S.
- * The temperature unit is °C.
- * The air flow unit is CMM.
- * The air flow area is meter² (meter square).
- * The sampling time of data logger function is 2 seconds.

4-1 Air velocity /Air Temp. measurement

- 1) Install the " Probe Plug " (3-19, Fig. 1) into the " Probe Input Socket " (3-17, Fig. 1).

Attention :

After install the " Probe Plug ", should slide Probe Lock Switch " (3-18, Fig. 1) to the On position (right position).

- 2) Power on the meter by pressing the " Power Button " (3-2, Fig. 1).
- 3) Select measuring function by pressing " Function Button " (3-6, Fig. 1) until the display show the air velocity unit.
 - @ Air velocity measurement, the display unit will show m/S (or Ft/min, Km/h, Knots, Mile/h).
 - @ The Air velocity unit adjustment, please refer Chapter 5-7.

- 4) Hold the " Vane Probe Handle " (3-21, fig. 1) by hand & let the " Vane Probe Head " (3-20, Fig. 1) face against the measuring air flow source, then the Display (3-1, Fig. 1) will show air velocity directly. At the same time, the display will show the air temperature value. @ The Temp. unit adjustment, please refer Chapter 5-6.

Measuring Consideration :

The yellow dot mark on the sensor head indicates the direction that " need to face against the air flow.

4-2 Air flow (CMM, CFM) measurement

- 1) Install the " Probe Plug " (3-19, Fig. 1) into the " Probe Input Socket " (3-17, Fig. 1).

Attention :

After install the " Probe Plug ", should slide Probe Lock Switch " (3-18, Fig. 1) to the On position (right position)

- 2) Power on the meter by pressing the " Power Button " (3-2, Fig. 1).
- 3) Select measuring function by pressing " Function Button " (3-6, Fig. 1) until the display show the air flow unit (CMM or CFM).
- @ Air flow measurement, the display unit will show CMM (or CFM).
- @ CMM : cube meter per minute.
CFM : cube feet per minute.
- @ The air flow unit adjustment, please refer Chapter 5-8.

- 4) The display's bottom left side will show area size in Meter² (or Ft²) when make the air flow measurement.
@ Meter² : Meter square, Ft² : Feet square.
@ The adjusting procedures of area size, please refer Chapter 5-9.
- 5) Hold the " Vane Probe Handle " (3-21, fig. 1) by hand & let the " Vane Probe Head " (3-20, Fig. 1) is opposite to the measuring air flow source, then the Display (3-1, Fig. 1) will show air flow value.

Measuring Consideration :
The yellow dot mark on the sensor head indicates the direction that " need to face against the air flow.

4-3 Thermocouple (Type K/J) Thermometer measurement

- 1) Not install the anemometer " Probe Plug " (3-19, Fig. 1) into the " Probe Input Socket " (3-17, Fig. 1)

Attention :
After take away the anemometer " Probe Plug " , then should slide Probe Lock Switch " (3-18, Fig. 1) to the On position (right position)

- 2) Plug the Thermocouple Temp. Probe (Type K Temp. probe or Type J Temp. probe, optional) into " Type K/J Probe Input Socket " (3-16, Fig. 1)

- 3) Power on the meter by pressing the " Power Button " (3-2, Fig. 1).
- 4) For the Type K Probe, press the " Function Button " (3-6, Fig. 1) to let the bottom right LCD show the " K type " indicator
For the Type J Probe, press the " Function Button " (3-6, Fig. 1) to let the bottom right LCD show the " J type " indicator

4-4 Data Hold

During the measurement, press the " Hold Button " (3-3, Fig. 1) once will hold the measured value & the LCD will display a " HOLD " symbol.

- * Press the " Hold Button " once again will release the data hold function.

4-5 Data Record (Max., Min. reading)

- * The data record function records the maximum and minimum readings. Press the " REC Button " (3-4, Fig. 1) once to start the Data Record function and there will be a " REC. " symbol on the display.

- * With the " REC. " symbol on the display :

- a) Press the " REC Button " (3-4, Fig. 1) once, the " REC. MAX. " symbol along with the maximum value will appear on the display.

If intend to delete the maximum value, just press the " Hold Button " (3-3, Fig. 1) once, then the display will show the " REC. " symbol only & execute the memory function continuously.

- b) Press the " REC Button " (3-4, Fig. 1) again, the " REC. MIN. " symbol along with the minimum value will appear on the display.
If intend to delete the minimum value, just press the " Hold Button " (3-3, Fig. 1) once, then the display will show the " REC. " symbol only & execute the memory function continuously.
- c) To exit the memory record function, just press the " REC " button for 2 seconds at least. The display will revert to the current reading.

4-6 Data Logger

The data logger function can save 16,000 measuring data with the clock time (Real time data logger, build in clock (hour-min.-sec., year-month-date).

The data logger procedures are as following :

- a) If push the Logger Button " (3-8, Fig. 1) once will show the sampling time value on the bottom left display then disappeared.
- b) Press the " REC Button " (3-4, Fig. 1) once to start the Data Record function and there will be a " REC. " symbol on the display.
- c) **Auto Data Logger (Sampling time set from 2 seconds to 8 hours 59 minutes 59 seconds)**
Press the " Logger Button " (3-8, Fig. 1) once to start the Auto Data Logger function, at the same the bottom right display will show the indicator " Recording.... ", now the Data Logger function is executed. The upper display will show DATA " indicator along with " REC " marker.

d) Manual Data Logger (Sampling time set to 0 second)

Press the " Logger Button " (3-8, Fig. 1) once will save the data one time into the memory, at the same time the bottom right display will show the indicator " Recording.... " a while. Now the Data logger function is executed. The upper display will show " DATA " indicator along with " REC " marker.

e) Memory full

Under execute the data logger, if the bottom right display show the " Full ", it indicate the memory data already over 16,000 no. and the memory is full.

f) During the Data Logger function is executed, press the " Logger Button " (3-8, Fig. 1) once will stop to execute the data logger function, the " DATA " indicator will be disappeared.

If press the " Logger Button " (3-8, Fig. 1) once again will continuous the Data Logger function.

Remark :

- 1) If intend to change the data logger sampling time, please refer chapter 5-4.*
- 2) If intend to know the space of balance data numbers into the memory IC, please refer chapter 5-1.*
- 3) If intend to clear the saving data from the memory please refer chapter 5-2.*

5. ADVANCED ADJUSTMENT PROCEDURES

When execute the following Advanced Adjustment Procedures should cancel the " Hold function " and the " Record function " first. The display will not show the " HOLD " and the " REC " marker.

- a. Press the " SET Button " (3-8, Fig. 1) at least two seconds until the lower display show

XXXXX Memory Space

* If push the " ESC Button " (3-3, Fig. 1) will escape the selecting function and return to the normal measuring display.

- b. One by one to press the " Set Button " (3-8, Fig. 1) once a while to select the ten main function, at the same time lower display will show on the lower display will show on the lower display as :

Memory Space
Clear Memory
Date/Time Set
Sample Time
Auto Power Off
Temp. Unit
Default Vel.
Default FLOW
Area
ESC→Finish

c. When make Advanced Adjustment Procedure will use the following key buttons :

ESC Button (3-3, Fig. 1), Enter Button (3-4, Fig. 1)
 ▲ Up Button (3-5, Fig. 1), ▼ Down Button (3-6, Fig. 1)
 SET Button (3-8, Fig. 1), SEND Button (3-7, Fig. 1)

5-1 Check Memory Space

To check the balance data numbers that exist into the memory (allow memorize data no.).

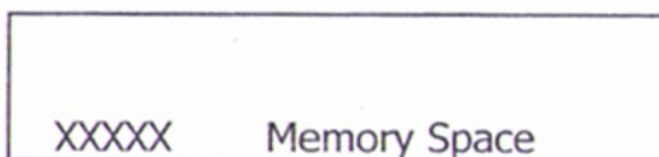

@XXXXX is the balance data numbers, for example
 XXXXX=15417.

5-2 Clear Memory

- * To delete the existing save data numbers from the memory.
- * Push ENTER Button once, then push ENTER Button to confirm.
- * Press the ESC Button once to quite and return to the main measurement manual.

5-3 Date/Time Setting

- * Use ▲ Up Button, ▼ Down Button and Enter (→) Button to select the expect Date (year-month-date) and the time (HOUR-MIN.-SEC.).
- * After finish the Date/Time adjustment, Push the " Enter Button " , then press the " ESC Button " will quite and save the clock data into the memory.

5-4 Sample Time Setting

- * Use ▲ Up Button, ▼ Down Button and Enter (→) Button to select the expect Sample Time (HOUR-MIN.-SEC.).
- * After finish the Sample Time adjustment, Push the " Enter Button " , then press the " ESC Button " will quite and save the clock data into the memory.

5-5 Auto Power Off Default Setting

- * Use ▲ Up Button, ▼ Down Button to select " 1 " or " 0 ".

1 = Auto power On.
0 = Auto power Off.

- * After finish the Auto Power Off adjustment, push the " Enter Button " , then press the " ESC Button " will quite and return to the normal measurement display.

5-6 Temp. Unit Default Setting

- * Use ▲ Up Button, ▼ Down Button to select " 1 " or " 0 ".

1 = °F
0 = °C

- * After finish the Temperature unit adjustment, push the " Enter Button " , then press the " ESC Button " will quite and return to the normal measurement display.

5-7 Air Velocity Unit Default Setting

- * Use ▲ Up Button, ▼ Down Button to select the default Air Velocity unit as :
m/S, Ft/min, Km/h, Knots, Mile/h,
- * After finish the Air Velocity unit adjustment, push the " Enter Button " , then press the " ESC Button " will quite and return to the normal measurement display.

5-8 Air Flow Unit Default Setting

- * Use ▲ Up Button, ▼ Down Button to select the default Air Flow unit as : CMM or CFM
CMM : cube meter per minute.
CFM : cube feet per minute.
- * After finish the Air Flow unit adjustment, push the " Enter Button " first, then press the " ESC Button " again will quite and return to the normal measurement display.

5-9 Area Size (Air Flow) Default Setting

- * Use ▲ Up Button, ▼ Down Button and the SEND (→) to select the desired area value.
@If the 5-8 select the CMM, the area unit is
Meter² (Meter square) and the adjust range is limited to 0.001 to 30.000 Meter square.
@If the 5-8 select the CFM, the area unit is
Feet² (Feet square) and the adjust range is limited to 0.01 to 322.92 Feet square.
- * After finish the Area Size adjustment, push the " Enter Button " first, then press the " ESC Button " again will quite and return to the normal measurement display.

5-10 Escape from the SETTING function

Press the " ESC Button " once a while will quite and return to the normal measurement display.

6. HOW TO SEND THE DATA OUT FROM THE METER

- 1) If intend to send the data out from the meter, it should cancel the " Hold function " and the " Record function " first. The display will not show the " HOLD " and the " REC " marker.
- 2) Press the " SEND Button " (3-7, Fig. 1) at least 2 seconds until the bottom right display show " Transmit mode ", then release the button.

LCD display will show the fowling screen alternately.

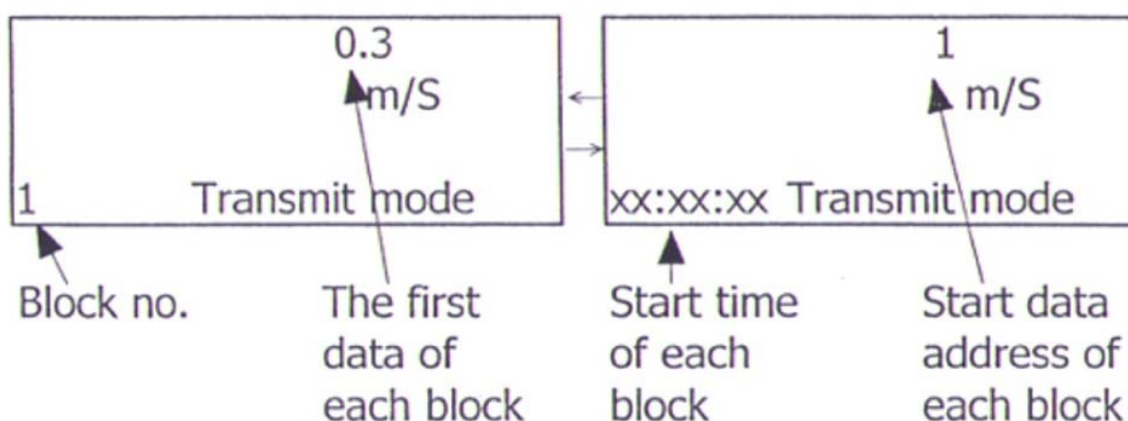

Use ▲ Up Button, ▼ Down Button to select the different data memory block no. (1 to 250).

The meter can save 16,000 data max. , those data will saved into 250 memory block max.

* One " Memory Block " means :

The data that save into one routine Data Logger procedures (Push " REC " button , following push the " Logger " button to save the data, the display will show the " REC " and " DATA " . After save the data push the " Logger " button, following push the " REC " button, will exist the Data Logger function. The " REC " and " DATA " indicator of LCD will be disappeared). Please refer Chapter 4-6, page 12.

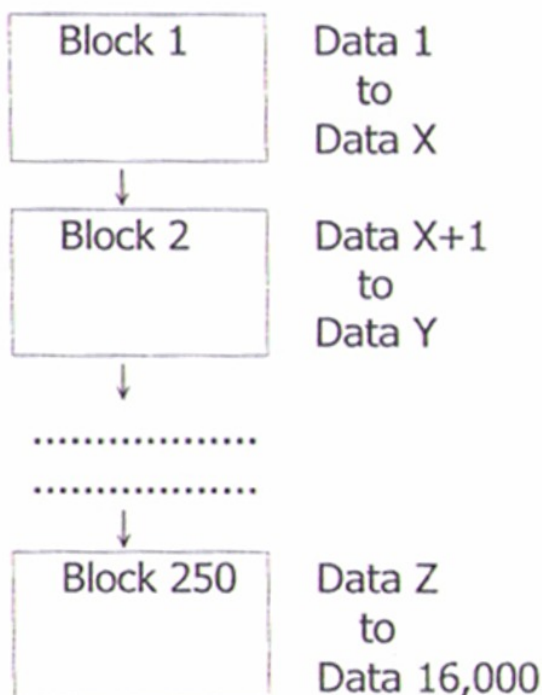

- 3) Until the desired Memory Block no. be selected.
Push the " Send Button " (3-7, Fig. 1) once, the data in the Memory Block will send out.
During the data send out, the bottom right display will show the " Sending Data ! " indicator. When data already send out completely, the bottom right display will show the Transmit mode " indicator again.
- 5) Push the " ESC Button " (3-3, Fig. 1) will exist the data sending function and return to the normal display.

Remarks :

@ If intend up load the data to the computer, then should connect the RS232 cable (optional, model : UPCB-02) and apply the Data Logger software (optional, Model : SW-DL2005).

@ When sending the data, each time just can send one Memory Block data out. for example block 1 data, block 2 data... or block 250 data.

7. RS232 PC SERIAL INTERFACE

The instrument has RS232 PC serial interface via a 3.5 mm terminal (3-14, Fig. 1).

The data output is a 16 digit stream which can be utilized for user's specific application.

A RS232 lead with the following connection will be required to link the instrument with the PC serial port.

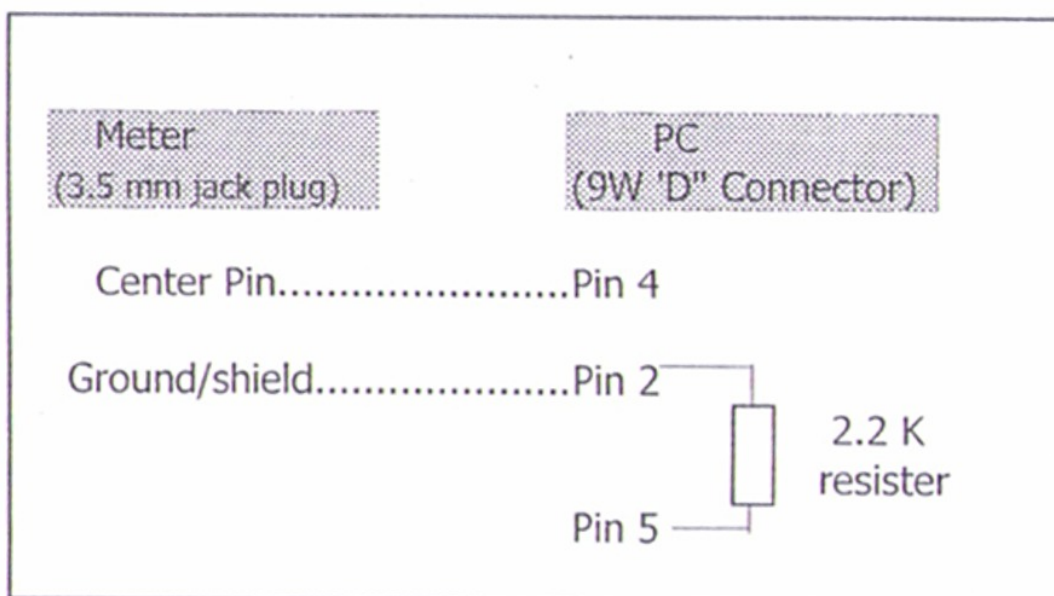

The 16 digits data stream will be displayed in the following format :

D15 D14 D13 D12 D11 D10 D9 D8 D7 D6 D5 D4 D3 D2 D1 D0

Each digit indicates the following status :

D0	End Word = 0D		
D1 & D8	Display reading, D1 = LSD, D8 = MSD For example : If the display reading is 1234, then D8 to D1 is : 00001234		
D9	Decimal Point(DP), position from right to the left 0 = No DP, 1= 1 DP, 2 = 2 DP, 3 = 3 DP		
D10	Polarity 0 = Positive 1 = Negative		
D11 & D12	Annunciator for Display		
	°C = 01	Knot = 09	mile/h = 12
	°F = 02	Km/h = 10	CMM = 84
	m/S = 08	ft/min = 11	CFM = 85
D13	When send the upper display data = 1 When send the lower display data = 2		
D14	4		
D15	Start Word = 02		

RS232 setting

Baud rate	9600
Parity	No parity
Data bit no.	8 Data bits
Stop bit	1 Stop bit

8. BATTERY REPLACEMENT

1) The time to change the UM3 (1.5 V) x 4 PCs

When the left corner of LCD display show "  ", it is necessary to replace the batteries (UM3/1.5 V x 4 PCs).

The time to change the CR2032 (3V silver battery)

When the clock is not accurate or power off the meter then on, the clock time is disappeared or garbled, it is necessary to replace the battery (CR2032)

- 2) Slide the " Battery Cover " (3-10, Fig. 1) away from the instrument and remove the battery.
- 3) Replace with batteries (UM3/1.5 V x 4 PCs or CR2032) and reinstate the cover.
- 4) Make sure the battery cover is secured after changing the battery.

9. SYSTEM RESET

If the meter happen the troubles such as :

CPU system is hold (for example, the key button can not be operated...).

Then make the system RESET will fix the problem.
The system RESET procedures will be either following method :

- 1) Slide the " Probe Lock Switch/System On/Off Switch " from the On to Off, then On again.
- 2) Or during the Power On, used a pin tool to push the " System Reset Switch " (3-13, Fig. 1) once a while.

10. OPTIONAL ACCESSORIES

RS232 cable UPCB-02	* Isolated RS232 cable. * Used to connect the meter to the computer
Data Logger software SW-DL2005	* Software the used to download the data logger (data recorder) from the meter to computer.
Data Acquisition software SW-U801-WIN	* The SW-U801-WIN is a multi displays (1/2/4/6/8 displays) powerful application software, provides the functions of data logging system, text display, angular display, chart display, data recorder high/low limit, data query, text report, chart report.. .xxx.mdb data file can be retrieved for EXCEL, ACCESS., wide intelligent applications.

Thermocouple Probe (Type K) TP-01	<ul style="list-style-type: none"> * Measure Range: -40 °C to 250 °C, -40 °F to 482 °F. * Max. short-tern operating Temperature: 300 °C (572 °F). * It is an ultra fast response naked-bead thermocouple suitable for many general purpose application.
Thermocouple Probe (Type K), TP-02A	<ul style="list-style-type: none"> * Measure Range: -50 °C to 900 °C, -50 °F to 1650 °F. * Dimension: 10cm tube, 3.2mm Dia.
Thermocouple Probe (Type K), TP-03	<ul style="list-style-type: none"> * Measure Range: -50 °C to 1200 °C, -50 °F to 2200 °F. * Dimension: 10cm tube, 8mm Dia.
Surface Probe (Type K), TP-04	<ul style="list-style-type: none"> * Measure Range: -50 °C to 400 °C, -50 °F to 752 °F. * Size : Temp. sensing head - 15 mm Dia. Probe length - 120 mm.



info@tursdaletechnicalservices.co.uk

In this direction will find a vision of the measurement technique:
<http://www.industrial-needs.com/measuring-instruments.htm>

NOTE: "This instrument doesn't have ATEX protection, so it should not be used in potentially explosive atmospheres (powder, flammable gases)."