



Manual
Compact Scale / Balance
PCE-BSH 6000 / 10000



1. SAFETY PRECAUTIONS.....	2
△ WARNING	2
△ CAUTION	2
2. PARTS DESCRIPTION	3
3. PREPARATION.....	4
1. Installing batteries/Connecting the AC adaptor	4
2. Setting up the scale/balance	4
3. FUNCTION SETTINGS	4
4. WEIGHING.....	5
Before weighing	5
Error messages	5
Weighing procedures.....	5
5. CALIBRATION	6
When to calibrate	6
How to calibrate.....	6
6. FEATURES.....	6
7. SPECIFICATIONS	6
8. Counting procedures.....	7

1. SAFETY PRECAUTIONS

All safety messages are identified by the following the words "**WARNING**" and "**CAUTION**". These words mean the following:

WARNING	Important information to alert you to a situation that might cause serious injury and damage to your property if instructions are not followed.
□ CAUTION	Important information that tells how to prevent damage to equipment.

When using the scale/balance, the following safety precautions should always be followed.

WARNING

Use only the AC adaptor with the scale/balance. Other adaptor may cause damage. (AC adaptor is optional)

CAUTION

Avoid installing the scale/balance in direct sunlight; this may cause discoloration or malfunctions.

Do not mix the type of batteries. Replace all other batteries at the same time.

If the scale/balance is not to be used for a long period of time, remove all batteries from the battery compartment to avoid leakage which may cause damage to the instrument.

Avoid overloading that could cause damage to the scale/balance.

Do not drop water in the scale/balance that is not water-resistant. It causes damage, if inside of the scale/balance is wet.

Matter charged static electricity could influence the weighing. Discharge the static electricity. As example, the method is to use the electrification prevention spray, to spray it to both side of weighing platform.

2. PARTS DESCRIPTION

▶ RIGHT SIDE

AC adaptor
Socket



▶ TOP

Display

ON/OFF key
Turns the scale
power on/off.

ZERO key
sets display to zero

PRINT key

UNIT key
Changes weighing units, g ,ct, oz, tola

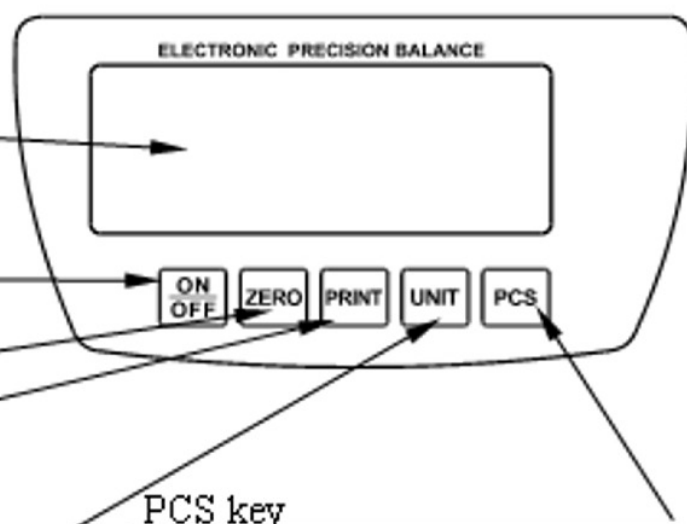

PCS key

▶ BOTTOM

Switch key
Battery compartment

Battery compartment cover

Batteries
Use 6 AA batteries

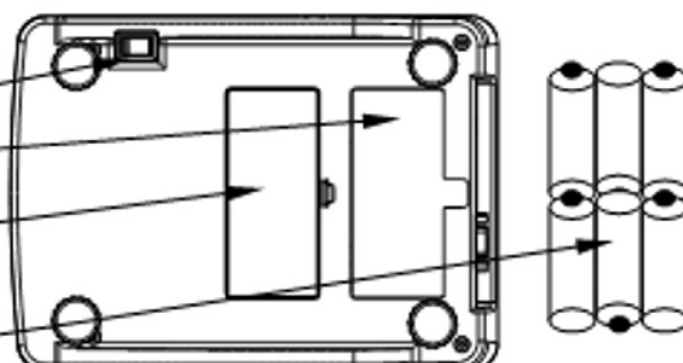

▶ DISPLAY

Low battery indicator

Negative value indicator

STABLE indicator
when the reading is stable.

weighing unit

TARE indicator

Print indicator

ZERO indicator



3. PREPARATION

1. Installing batteries/Connecting the AC adaptor

Batteries

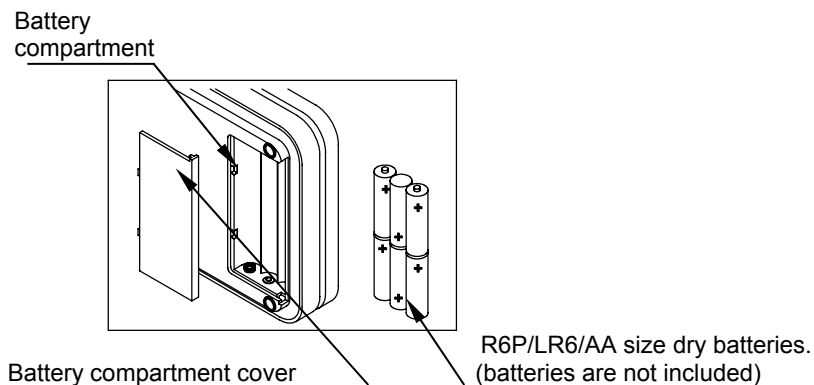

Remove the battery compartment cover and insert six batteries(R6P/LR6 /AAsize) into the battery compartment, taking extreme care that the polarities plus and minus is observed.

AC adaptor (optional)

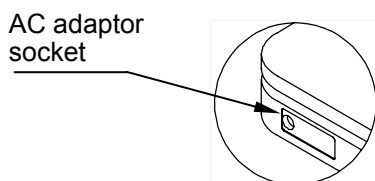

Plug the AC adaptor to the AC adaptor socket on the side. The AC input requirement could be 110,120,220,230 or 240Volts (50/60Hz) depending on the area where used, so please verify that the adaptor is correct

2. Setting up the scale/balance

⚠CAUTION!!

Avoid installing the scale/balance in direct sunlight that may cause discoloration or malfunctions. Place your scale/balance on a firm weighing table so that the scale/balance is level. (The scale/balance will not perform accurately when it is not level.)

Place the scale/balance on the firm surface that is flat and level for an accurate weighing.

3. FUNCTION SETTINGS

1. Press **[ON/OFF]** to turn on the scale, the display will show flash digits and then -----,press **[PRINT]**, the display will show b xxx BAU value (press **[UNIT]** to select among 1200,2400,4800,9600), our default setting is 9600.

Press **[ZERO]** to enter Parity mode, the display will show P XXX PAR, press **[UNIT]** to select odd, even, none (odd stands for 7 data bits with odd parity, even stands for 7 data bits with even parity,none stands for 8 data bit without parity)our default setting is none.

Press **[ZERO]** to enter Print mode, the display will show n xxx Mod, press **[UNIT]**to select ON, OFF, KEY, STB (OFF stands for serial data output disabled, KEY stands for demand mode by press **[PRINT]**, STB stands for automatic print when scale is stable, ON stands for continuous print, our default setting is STB. press **[ZERO]** again to return to weighing mode.

2. Press **[ON/OFF]** to turn on the scale, the display will show flash digits and then -----, press **[UNIT]** to enter unit selecting function, the display will show ON X (X stands for the units: g, oz, lb, twt...tola..), press **[UNIT]** to select ON (activate the selected unit) or OFF (inactive the selected unit) press **[ZERO]** to return to weighing mode.

3. Switch the power to "ON" and than press **[ON/OFF]**to turn on the scale. The display shows F-E-9 to 0 and than "-----" press **[TARE]** key to enter ZERO track function setting display shows ZRD x.xd press **[UNIT]** key to select ZERO track value 0.0d-0.5d-1.0d-1.5d-2.0d); press **[TARE]**key to enter ZERO track function setting display shows ZRT x.xd, press **[UNIT]** key to select ZERO track time (0.5 to 4.0 seconds); press **[ZERO]** key to enter ZERO setting, display shows RZD XXX, press **[UNIT]** key to select ZERO value 0.8d-

1.8d-2.8d-3.8d); press [ZERO] key to enter **FIL** setting, press [UNIT] key to select filter range amend (0-1-2-3-4-5-6-7), "2" is default setting; press [ZERO] key to select zero range when turn on the scale, press [UNIT] key to select percent (PZR 2, PZR 5, PZR 10, PZR 20); press [ZERO] key to set zero range, press [UNIT] key to select percent (**KZR**

3, 4, 5, 10); press [ZERO] key to set TARE range, press [UNIT] key select percent (KTR 50 or KTR 100); press [ZERO] key to enter overload protection setting, press [UNIT] key to select overload protection value (9d OVR-1 OVR-2 OVR-10 OVR);

press [ZERO] key to set beep function, press [UNIT] key to choose turn on or turn off the beep, "bz ON" means activate the beep, "bz OFF" means inactivate the beep; press [ZERO] key to unite the function of TARE and ZREO, press [UNIT] to switch between them. "ZT ON" means unite function activate, "ZT OFF" means unite function inactivate. press [ZERO] key to enter auto off function setting, display shows A xxx, press [UNIT] to select auto off time (3, 5, 10, off); press [**ZERO**] to select backlight, the display will show X BL, press [UNIT] to select **X** value (**X** stands for AUTO, OFF, ON), OFF stands for inactivate backlight function, ON stands for the backlight is always make function, AUTO stands for auto backlight .

4. Press [**ZERO**] to return to weighing mode.

4. WEIGHING

Before weighing

Whenever possible, please allow the balance to warm up for 10 minutes after first turning to power on, so that the balance will function. Properly and accurately.

Error messages

EEEE: Overload

: Low battery

Calibration may be required before weighing.

Read "CALIBRATION" first and if necessary, calibrate your scale/balance for accurate weighing.

Weighing procedures

1. Press [ON/OFF] to turn on the scale/balance.

When power is turned on, all display segments appear on LCD for a few seconds and finally "0" will appear on the display.

2. Select the weighing unit with [UNIT].

Press [UNIT] to select a weighing unit, eg. "g" " ct " " oz " " tola "

Once the unit has been selected, the selected unit will be displayed to the weight value.

3. Start weighing

→ If you do not use a container for weighing,

Verify the reading is "0". If not, press [**ZERO**] to display "0". Place objects on the weighing platform to weigh. When the reading becomes stable, the stable indicator is displayed.

→ If you use a container for weighing,

Place an empty container on the platform.

Wait for the stability indicator to be displayed and press [**ZERO**].

Place the objects to be weighed in the container.

When the reading becomes stable, the stable indicator is displayed.

5. CALIBRATION

When to calibrate

Calibration may be required when it is initially installed, if the scale/balance is moved to a substantial distance. This is necessary because the weight of a mass in one location is not necessarily the same in another location. Also, with time and use, mechanical deviations may occur.

How to calibrate

1. Before entering calibration mode, **there is a switch key on the bottom of the scale. Turn on the switch key first**, press [ON/OFF] to turn the power on for 1minutes.

2. Enter calibration mode

Press [ON/OFF] to turn the power on. the display will show flash digits and then “-----”, Press [ZERO] , the display will show “CAL” , Press [ZERO] again , the display will show “X0000 CAL” , X is flash digit. Press [UNIT] key the flash digit will move to right; Press [PCS] key to increase the flash digit. **(X is the calibration weight which can be setted according to your requirement)**

3. Calibration by the weight

When you selected the calibration weight, and then place the calibration weight on platform. Then press [ZERO] key, the display return to the weight value, now the calibration is complete.

4.Press [ON/OFF], turn off the power, press [ON/OFF] turn on the power again, place the weight on the platform to make sure whether weighing is correct, if not, repeat steps 2-4.

5. Return to weighing mode

Press [ON/OFF] to turn the power off. Press [ON/OFF] again to turn on the power and the scale/balance return to the weighing mode.

6. FEATURES

- Auto shut off (optional).
- Auto zero tracking
- Low batter indication
- Lager LCD Display
- Large square weighting pan
- 1/120000&1/15000 division available
- Auto calibration
- Auto backlight (optional)
- g/ct/oz/tola..... conversion(optional)
- with counting function(optional)
- Net weight/stability indication

7. SPECIFICATIONS

Model number	Capacity	Division
PCE-BSH 6000	6000g	0.1g/0.2g
PCE-BSH 10000	10000g	0.2g/0.5g/1g
Platter	φ115mm or 170 x 180mm	
Net/gross weight	1350/1500g	
Package	Standard carton: 34×22×14(cm ³)	
	6 Units in one box: 47.5×38.5×45(cm ³)	
Operating Temperature	0-40 (32-104)	
Power source	Batteries or AC/DC	
	Adapter 9V/100mA (optional)	

8. Counting procedures

1. Press [ON/OFF] to turn on the scale.

Wait for "0" to appear on the display.

2. Start the Count Procedure

If necessary, press [ZERO] key to set the display to "0".

3. Press the [PCS] key to put the scale in PCS mode. ,the display will show P=X X ,press UNIT to select XX value (10 20 50 100),Place a given number of samples of an item on the pan (the Sample Size should be either 10 20 50 or 100 pieces). The weight of these samples will show on the display.
4. Press the [PCS] key, the display will show "XX pcs", then the scale will recall the sample size you selected and show the starting sample size on the display (you can now remove the samples if you want to return the scale to 0)
5. Press the [PCS] key to return to the weighing mode

In this direction will find a vision of the measurement technique:
<http://www.industrial-needs.com/measuring-instruments.htm>

NOTE: "This instrument doesn't have ATEX protection, so it should not be used in potentially explosive atmospheres (powder, flammable gases)."