

PCE Americas Inc.
711 Commerce Way
Suite 8
Jupiter
FL-33458
USA

From outside US: +1
Tel: (561) 320-9162
Fax: (561) 320-9176
info@pce-americas.com

PCE Instruments UK Ltd.
Units 12/13
Southpoint Business Park
Ensign way
Hampshire / Southampton
United Kingdom, SO31 4RF

From outside UK: +44
Tel: (0) 2380 98703 0
Fax: (0) 2380 98703 9
info@pce-instruments.com

www.pce-instruments.com/english
www.pce-instruments.com

Manual Meteorological Station PCE-FWS-20



Version 2.1
Date of creation: 03.02.2016
Date of last change: 30.03.2016

Contents

1	Introduction	3
2	Safety notes	3
3	Specification	4
4	Setup	5
5	Notes	7
5.1	Glossary of Common Terms.....	7
5.2	Important Note	7
5.3	Operation Note	8
6	Operation	9
6.1	System Start	9
6.2	Positioning	9
6.3	Setting Up	9
6.3.1	Indoor temperature.....	10
6.3.2	Outdoor temperature.....	11
6.3.3	Indoor humidity.....	12
6.3.4	Outdoor humidity.....	12
6.3.5	Wind speed	12
6.3.6	Rain	13
6.3.7	Weather forecast.....	13
6.3.8	Pressure.....	14
6.3.9	Pressure bar graph	14
6.3.10	Time	14
6.3.11	Date.....	15
6.3.12	Memory	15
6.4	PC Connection	15
6.5	Data Storage	15
6.6	Data Recall	15
6.7	Connections and Software	15
6.8	PC software installation	16
7	Software	18
7.1	System Requirements	18
7.2	Installation of the “EasyWeather” Software	18
7.3	Basic Settings of the PC Software	18
7.4	System menu.....	19
7.4.1	Basic setting	19
7.4.2	Alarm settings	20
7.4.3	Max-Min Display.....	20
7.4.4	Language setting.....	21
7.5	Save.....	21
7.5.1	Tabular View	21
7.5.2	Graphic Display.....	22
7.6	Troubleshooting: Graphs are not being displayed	23
7.7	Data upload	24
7.7.1	Upload according to weather underground.....	24

7.8	Special notes to time synchronization between PC and base station.....	24
8	Disposal	25
9	Contact.....	25
9.1	PCE Instruments UK	25
9.2	PCE Americas	25

1 Introduction

Thank you for purchasing a meteorological station from PCE Instruments.

This Weather Station is a high quality, easy to use weather monitoring system that reads, displays and records the weather data from internal as well as external sensors. Besides the internally measured values for indoor temperature, indoor humidity and air pressure the outdoor sensor will take data for temperature and humidity, wind and rainfall. Operation of these units is by wireless transmission to the Base Station.

After installing the “EasyWeather” program on this CD-ROM, your PC can display all indoor data as well as the weather data from the Base Station received from the external sensors. For operation, simply use the USB cable supplied and connect the Base Station to the PC. From now on you can start to track current and history weather information at your fingertips.

2 Safety notes

Please read this manual carefully and completely before you use the device for the first time. The device may only be used by qualified personnel and repaired by PCE Instruments personnel. There is no warranty of damages or injuries caused by non-observance of the manual.

- The device may only be used in approved temperature range
- The opening of the case should only be done by qualified personnel of the PCE Instruments.
- The instrument should never be placed with the user interface (e.g. keyboard side on a table)
- You should not make technical changes on the device
- The appliance should only be cleaned with a damp cloth / use only pH-neutral cleaner

This user's handbook is published from PCE Instruments without any guarantee.

We expressly point to our general guarantee terms, they can be found in our general terms of business.

If you have any questions please contact PCE Instruments.

3 Specification

Outdoor data

Transmission distance in open field	100 m (330 feet)
Frequency	868 MHz (Europe) / 915 MHz (North America)
Temperature range	-40°C ... 65°C (-40 °F to +149 °F)
Resolution	0.1 °C (0.2 °F)
Measuring range rel. humidity	10 ... 90 %
Rain volume display	0 ... 9999mm (show --- if outside range)
Resolution	0.1mm (if rain volume < 1000mm) 1mm (if rain volume > 1000mm)
Wind speed	0...240km/h (0...100mph) (show --- if outside range)
Measuring interval thermo-hygro sensor	48 s
Water proof level	IPX3

Indoor data

Measuring interval pressure / temperature	48 s
Indoor temperature range	0 ... +50 °C (32°F to + 122°F) (show --- if outside range)
Resolution	0.1°C (0.2°F)
Measuring range rel. humidity	10 ... 90 %
Resolution	1%
Measuring range air pressure	700 ... 1100hpa (27.13inHg ... 31.89inHg)
Resolution	0.1hpa (0.01inHg)
Alarm Duration	120 s

Power consumption

Base station	3XAA 1.5V LR6 Alkaline batteries
Remote sensor	2xAA 1.5V LR6 Alkaline batteries
Battery life	Minimum 12 months for base station Minimum 24 months for thermo-hydro sensor

Remark: where outdoor temperature is lower than -20°C, make sure proper type of batteries to be used to assure that the device can get enough power to maintain its function properly. Normal alkaline batteries is not allow to be used since when outdoor temperature is lower than -20 °C, the battery's discharging capability is greatly reduced.

4 Setup

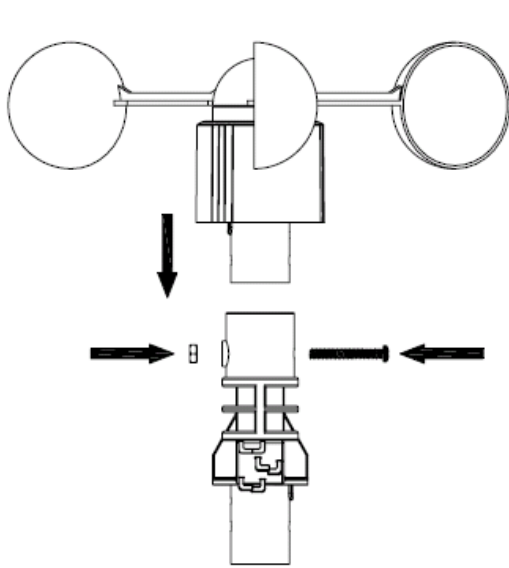

1

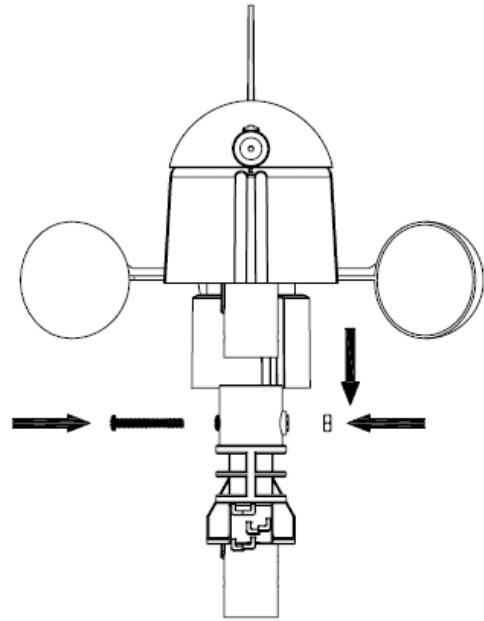

2

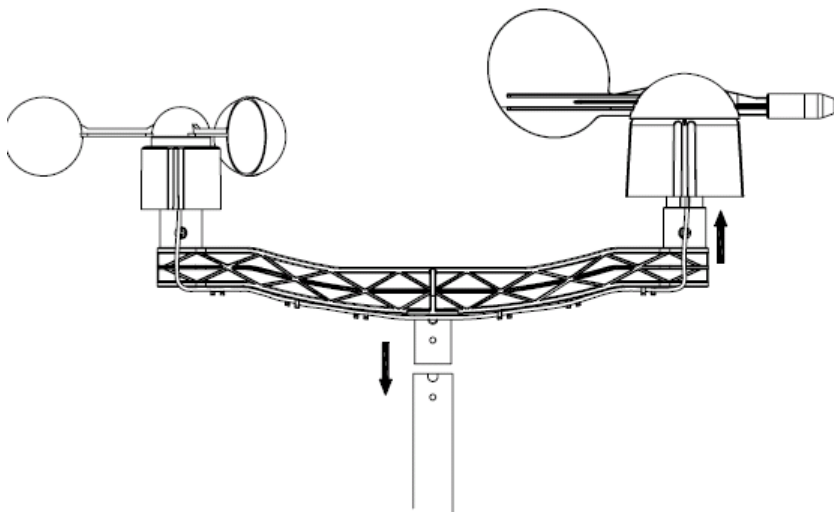

3

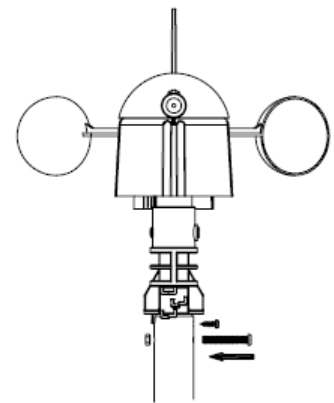

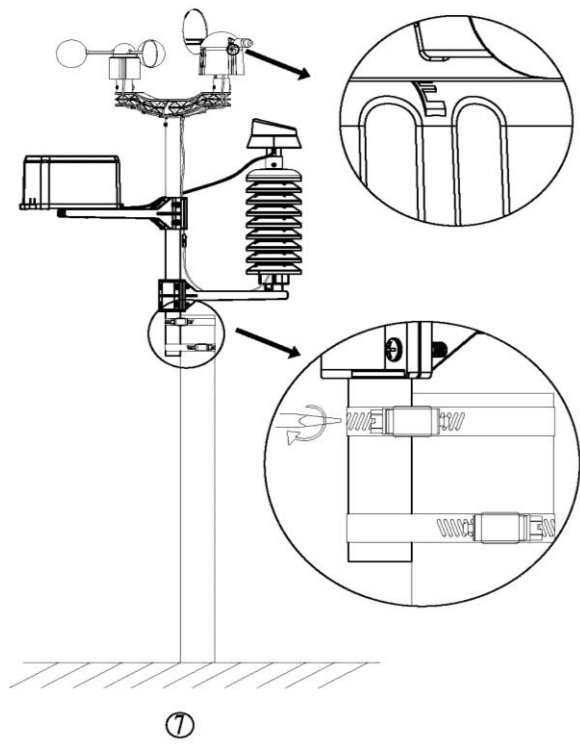
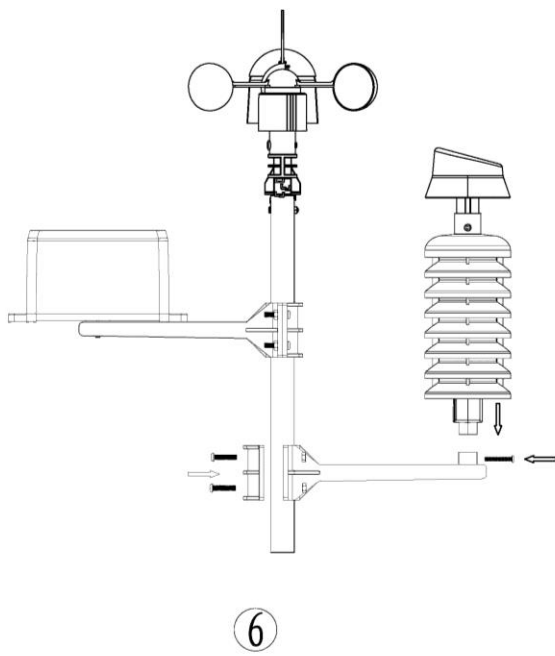
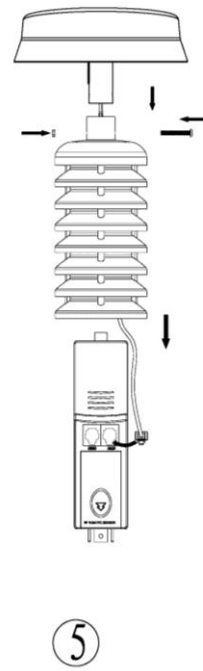
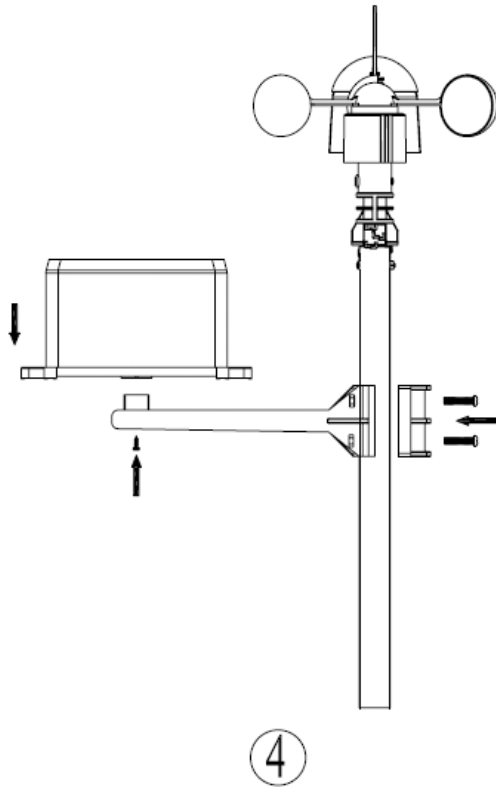

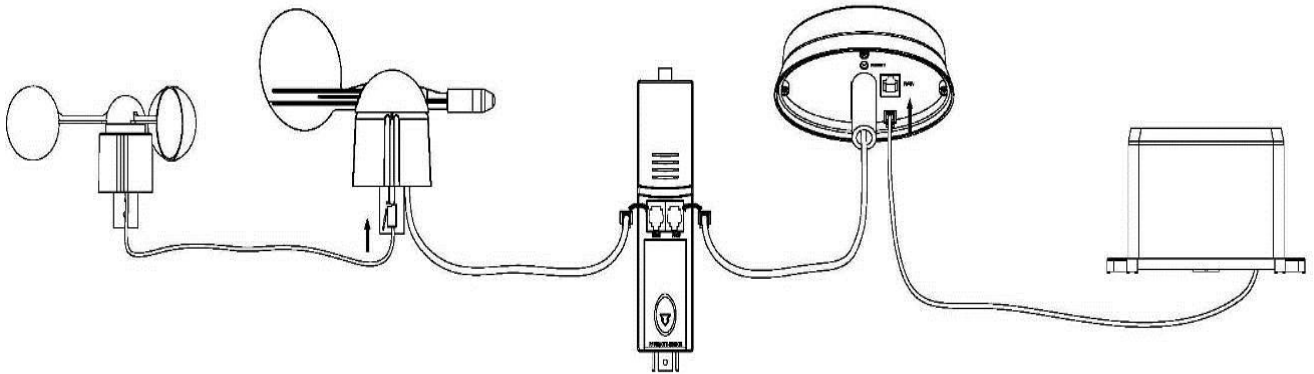

5 Notes

5.1 Glossary of Common Terms

DCF/WWVB

The DCF or WWVB time signal is an AM modulated time-of-day signal broadcasted by the Federal Government of Germany or NIST from USA. The time base is generated from an atomic time generator which is accurate to 10 billion of one second.

LCD

“LCD” is an acronym for “Liquid Crystal Display”. This is a common type of display screen used in televisions, computers, watches, and digital clocks.

BAROMETER & BAROMETRIC PRESSURE

A barometer is a device that measures the pressure of the air pushing on it—this measurement is called the barometric pressure. We don’t actually feel the barometric pressure because the air pressure is pushing equally in every direction.

RELATIVE AIR PRESSURE

Relative air pressure is the same as the barometric pressure. The calculation of relative air pressure is a combination of the absolute air pressure and the altitude.

ABSOLUTE AIR PRESSURE

Absolute air pressure is the actual air pressure on the barometer without regard to altitude.

INCHES OF MERCURY (inHg)

An inch of Mercury is the common unit of measurement for air pressure in the United States.

HECTOPASCALS (hPa)

Hectopascals are the common units of measurement for air pressure in the International System (SI) of measurement. The hectopascal holds the same value

5.2 Important Note

Before inserting batteries, please carefully read the operation manual.

The touch screen weather station PCE-FWS 20 includes a base station (receiver), a transmitter unit, one wind direction sensor, one wind speed sensor, one rain gauge, USB cable and a PC software package on CD-ROM.

The Base Station is equipped with a Touch Screen LCD Monitor and allows the display of a large variety of time and weather data.

Left Top LCD: IN-OUT temperature and humidity

Right Top LCD: Wind and Rain measurement

Left Middle LCD: Weather Forecast (Tendency)

Right Middle LCD: Air Pressure and Air Pressure History

Bottom Line LCD: Time and Date, Memory Data Usage

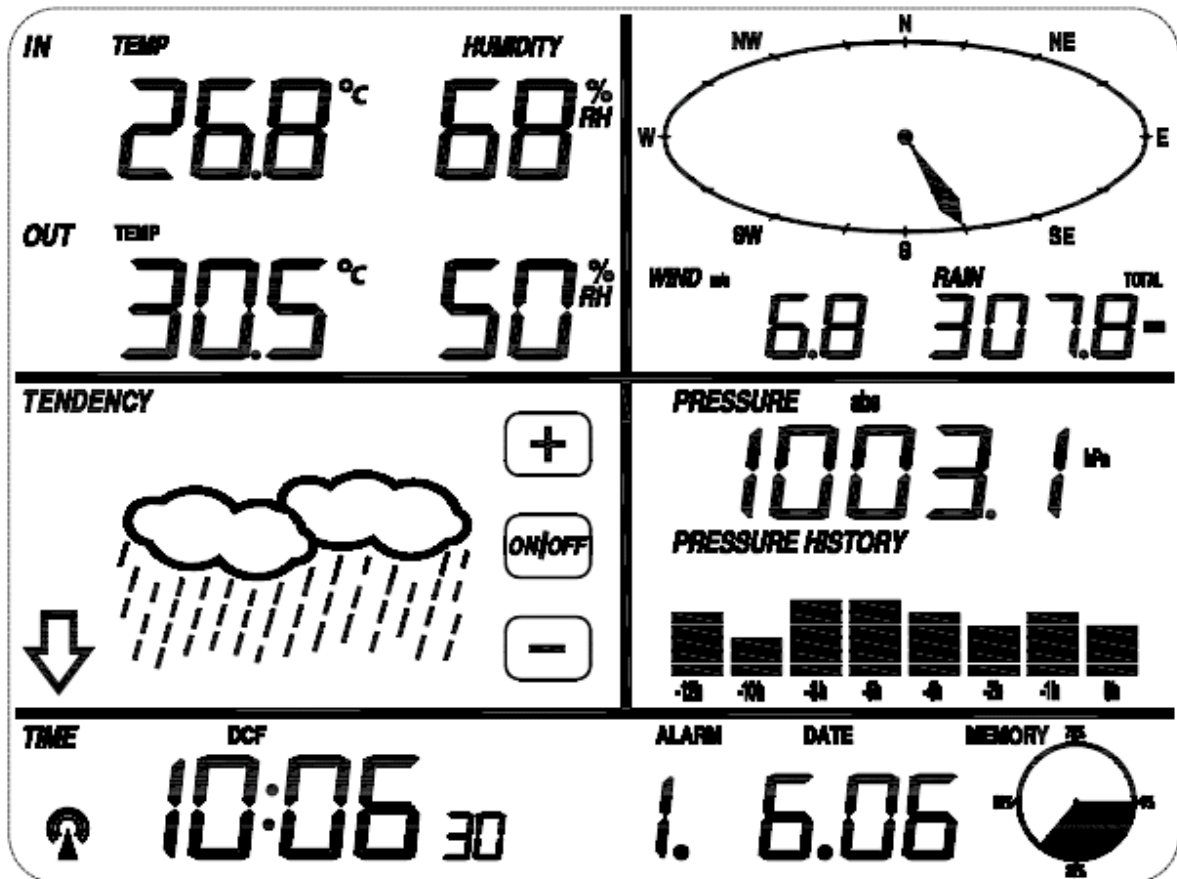

5.3 Operation Note

All actions and functions of the weather station are started on the touch screen by slightly touching (not pressing!) the related areas, touch the flashing +, ON/OFF or – to make the corresponding selection or increase the value.

Every time a programming step is activated by touching a switching area on the Touch Screen a tone will sound, and the back light is switched on for a few seconds as well.

If no areas are pressed for 30 seconds, the LCD will automatically revert to the normal display mode (automatic time out).

On the edge of wind direction sensor, there are four alphabet letter of “N”, “E”, “S” and “W” representing for the direction of North, East, South and West. Wind direction sensor has to be adjusted so that the directions on the sensor are matching with your real location. Permanent wind direction error will be introduced when the wind direction sensor is not positioned correctly during installation.

Wind speed sensor wire has to be inserted into the phone jacket on wind direction sensor. Wind direction sensor wire has to be inserted into the phone jacket located on the thermo-hygro sensor with marking of “Wind” on top.

The rain sensor wire has to be inserted into the phone jacket located on the thermo-hygro sensor with marking of “Rain” on top.

6 Operation

6.1 System Start

Insert two pieces of LR6 (AA size) batteries into the transmitter, the LED located in the middle front case of transmitter will be turned on for 4 seconds, and then it will be off and start to work normally. The transmitter will make a data transmission and then start radio controlled time reception routine. If time signal can be detected correctly, then the LED will start to flash 5 times indicating time signal has been found correctly. When time signal is bad and reception is not possible, the transmitter will terminate radio controlled time reception within one minute and resume normal mode. When there is a data transmission happened, the LED will be on for 20ms. During radio controlled time reception period, there is no transmission and normal transmission will only resume after time reception routine is complete. The longest time for radio controlled time reception is 5 minutes.

After inserting the batteries into the Weather Station, all LCD segments will be turned on for a few seconds; all possible display segments are turned on for checking.

After this, the weather station will make initial measurement and start to register the transmitter (the radio reception icon will be turned on). Before there is outdoor data received, it is not allowed to touch the LCD; otherwise the outdoor sensor learning mode will be terminated right after the touch of LCD. When outdoor transmitter has been registered, the Touch Screen Weather Station will automatically switch to the normal display mode from which all further settings can be performed by the user.

If no RCC signal is detected in the initial setup, the transmitter will try once every hour to get an RCC signal until a signal is received. Once the transmitter receives the RCC signal it will transmit the signal to the monitor. On the monitor the RCC icon will be displayed, if the monitor doesn't receive the RCC signal or loses the signal the RCC icon will not be display.

Note: The best condition for reception is at night, between midnight and 6:00am – when there is less atmospheric interference.

6.2 Positioning

Once you have verified that all of the components of the weather station are working, they can be positioned in their permanent places. Before permanently mounting, make sure that all components work properly together at their chosen mounting or standing locations. If e.g. there appear to be problems with the 868 MHz radio transmission, they can mostly be overcome by moving the mounting locations.

Note: Commonly the radio communication between receiver and transmitter in the open field can reach a distance of up to 330 feet providing that there are no interfering obstacles such as buildings, trees, vehicles, high voltage lines, etc.

Radio interferences such as PC screens, radios or TV sets can, in bad cases, entirely cut off radio communication. Please take this into consideration when choosing standing or mounting locations.

6.3 Setting Up

Note: Because of the default settings already determined by the manufacturer it may not be necessary for the majority of users to perform – except the Relative Air Pressure (see further down) - any further basic settings. Changes, however, can be easily made.

















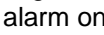

For basic settings, the following menu is started by touching the Touch Screen in the desired display area.

The basic settings can now be performed in the following successive order:

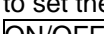
Note: setting procedure can be exited at any time by touching any other function area (except "+", "-" or "ON/OFF").

6.3.1 Indoor temperature

Activate the indoor temperature related setting by:

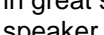
1. Touch the INDOOR TEMPERATURE section,  button and  button will be flashing. Touch the  button or  button to Shift the display unit between °C and °F.
2. Touch the INDOOR TEMPERATURE section again to set the indoor temperature high alarm function, the  button,  and  button will be flashing, HI AL icon will light up. Touch the  button or  button to change the value, hold the  button or  button for 3s to change the number in great step. Touch the  button to choose the alarm on or off (if alarm is enabled, the speaker icon will be turned on indicating the alarm function has been enabled).
3. Touch the INDOOR TEMPERATURE section the third time to set the indoor temperature low alarm function, the  button,  and  button will be flashing, LO AL icon will light up. Touch the  button or  button to change the value, hold the  button or  button for 3s to change the number in great step. Touch the  button to choose the alarm on or off (if alarm is enabled, the speaker icon will be turned on indicating the alarm function has been enabled).
4. Touch the INDOOR TEMPERATURE section the fourth time to display maximum indoor temperature record, the maximum records will be flashing, MAX icon will light up as well. Hold the flashing max value for 3s, the maximum value will be reset to current reading.
5. Touch the INDOOR TEMPERATURE section the fifth time to display minimum indoor temperature record, the minimum records will be flashing, MIN icon will light up as well. Hold the flashing min value for 3s, the minimum value will be reset to current reading.

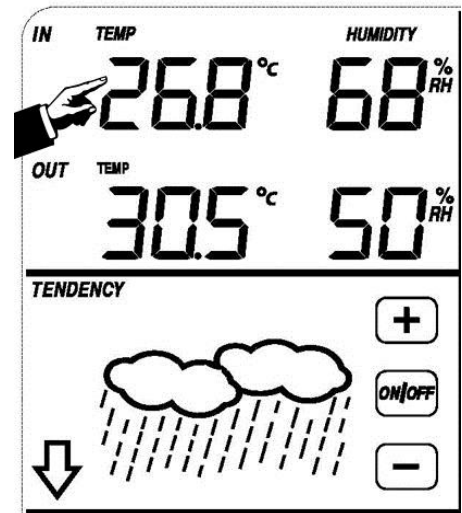

6.3.2 Outdoor temperature

Activate the outdoor temperature related setting by

1. Touch the OUTDOOR TEMPERATURE section, **+** button and **□** button will be flashing. Touch the **+** button or **□** button to Shift the display between Outdoor Temperature, Wind Chill and Dew Point.
2. Touch the OUTDOOR TEMPERATURE section again, **+** button and **□** button will be flashing. Touch the **+** button or **□** button to Shift the display unit between °C and °F.
3. Touch the OUTDOOR TEMPERATURE section the third time to set the outdoor temperature high alarm function, the **+**, **ON/OFF** and **□** button will be flashing, **HI AL** icon will light up. Touch the **+** button or **-** button to change the value, hold the **+** button or **□** button for 3s to change the number in great step. Touch the **ON/OFF** button to choose the alarm on or off (if alarm is enabled, the speaker icon will be turned on indicating the alarm function has been enabled).
4. Touch the OUTDOOR TEMPERATURE section the fourth time to set the outdoor temperature low alarm function, the **+**, **ON/OFF** and **□** button will be flashing, **LO AL** icon will light up. Touch the **+** button or **□** button to change the value, hold the **+** button or **□** button for 3s to change the number in great step. Touch the **ON/OFF** button to choose the alarm on or off (if alarm is enabled, the speaker icon will be turned on indicating the alarm function has been enabled).
5. Touch the OUTDOOR TEMPERATURE section the fifth time to display maximum outdoor temperature record, the recorded maximum value will be flashing, **MAX** icon will light up. Hold the flashing max value for 3s, the maximum value will be reset to current reading.
6. Touch the OUTDOOR TEMPERATURE section the sixth time to display minimum outdoor temperature record, the recorded minimum value will be flashing, **MIN** icon will light up as well. Hold the minimum value for 3s, the minimum value will be reset to current reading.

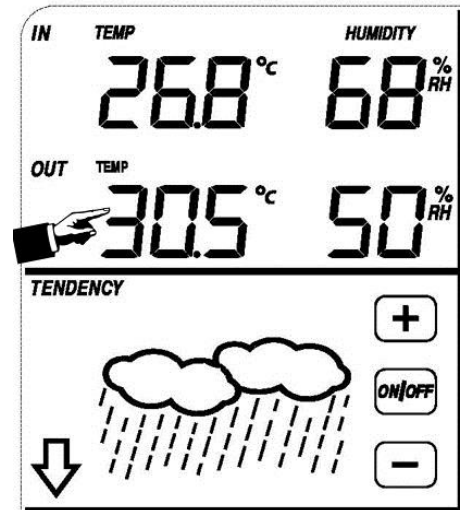

6.3.3 Indoor humidity

Activate the indoor humidity related setting by

1. Touch the INDOOR HUMIDITY section again to set the indoor humidity high alarm function, the **HI AL** icon will light up. Touch the **+** button or **-** button to change the value, hold the **+** button or **-** button for 3s to change the number in great step. Touch the **ON/OFF** button to choose the alarm on or off (if alarm is enabled, the speaker icon will be turned on indicating the alarm function has been enabled).
2. Touch the INDOOR HUMIDITY section again to set the indoor humidity low alarm function, the **LO AL** icon will light up. Touch the **+** button or **-** button to change the value, hold the **+** button or **-** button for 3s to change the number in great step. Touch the **ON/OFF** button to choose the alarm on or off (if alarm is enabled, the speaker icon will be turned on indicating the alarm function has been enabled).
3. Touch the INDOOR HUMIDITY section the third time to display maximum indoor humidity record, the recorded maximum value will be flashing, **MAX** icon will light up as well. Hold the maximum value for 3s, the maximum value will be reset to current reading.
4. Touch the INDOOR HUMIDITY section the fourth time to display minimum indoor humidity record, the recorded minimum value will be flashing, **MIN** icon will light up as well. Hold the minimum value for 3s, the minimum value will be reset to current reading.

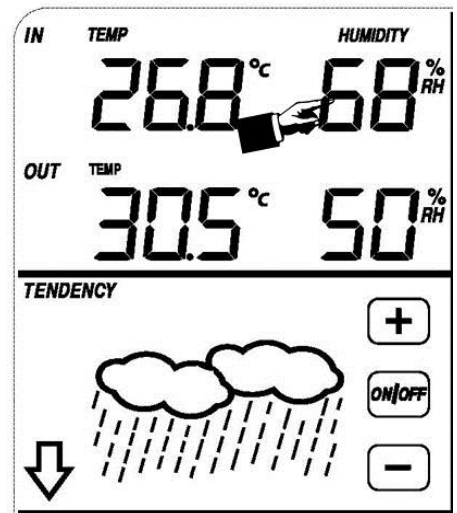

6.3.4 Outdoor humidity

Procedures and settings are similar to Indoor humidity

6.3.5 Wind speed





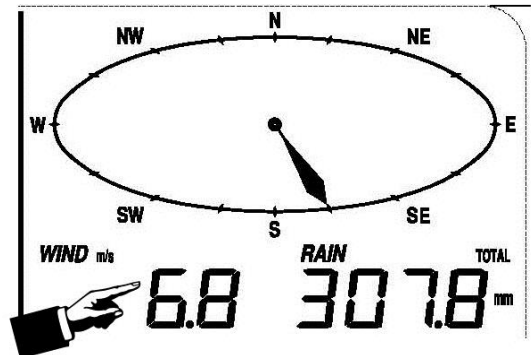











Activate the wind related setting by

1. Touch the WIND SPEED section, **+** button and **-** button will be flashing. Touch the **+** button or **-** button to Shift the display between Wind Average Speed and Gust Speed.
2. Touch the WIND SPEED section again, **+** button and **-** button will be flashing. Touch the **+** button or **-** button to select wind speed unit between km/h, mph, m/s, knots, bft.
3. Touch the WIND SPEED section the third time to set the high alarm function, the **HI AL** icon will light up. Touch the **+** button or **-** button to change the value, hold the **+** button or **-** button for 3s to change the number in great step. Touch the **ON/OFF** button to choose the alarm on or off (if alarm is enabled, the speaker icon will be turned on indicating the alarm function has been enabled).
4. Touch the Wind SPEED sections the fourth time to set wind direction alarm function, the wind direction arrow will start to flashing. Touch **+** or **-** to select desired alarm for wind direction, press **ON/OFF** to enable or disable the wind direction alarm.
5. Touch the Wind SPEED section the fifth time to display maximum wind speed record, the recorded maximum value will be flashing, **MAX** icon will light up as well. Hold the maximum value for 3s, the maximum value will be reset to current reading.









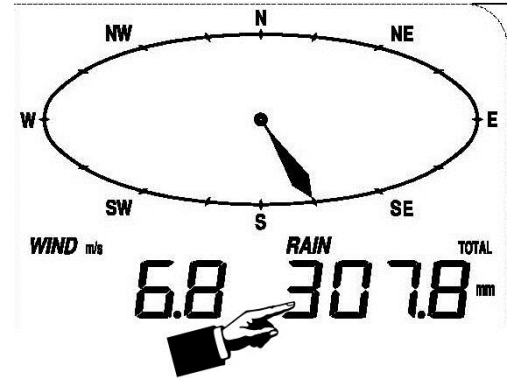





6.3.6 Rain

Activate the rain related setting by

1. Touch the rain section,  button and  button will be flashing. Touch the  button or  button to Shift the display between 1h,24h,week,month and total rain.
2. Touch the rain section again,  button and  button will be flashing. Touch the  button or  button to select rain fall unit between mm, inch.
3. Touch the rain section the third time to set the high alarm function, the  ,  and  button will be flashing, HI AL icon will light up. Touch the  button or  button to change the value, hold the  button or  button for 3s to change the number in great step. Touch the  button to choose the alarm on or off (if alarm is enabled, the speaker icon will be turned on indicating the alarm function has been enabled).
4. Touch the rain section the fourth time to display current maximum rain fall record. Touch the rain section for 3s will reset the maximum rain fall value to current value.
5. Touch the rain section the fifth time to reset rain fall value to 0 by pressing the rain section for 3s, and then 1h, 24h, week, month and total rain will be reset to 0.







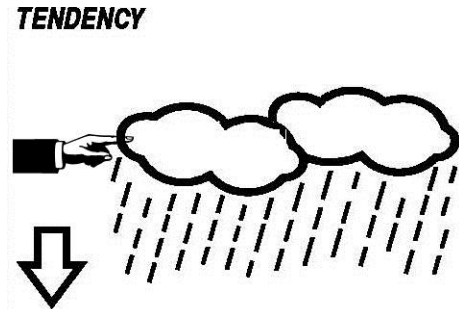





















6.3.7 Weather forecast

1. Touch the WEATHER FORECAST section,  button and  button will be flashing. Touch the  button or  button to Shift the display between SUNNY, PARTLY CLOUDY and CLOUDY, RAINY icon.
2. Touch the WEATHER FORECAST section again,  button and  button will be flashing. Touch the  button or  button to set the pressure threshold from 2-4hPa (default 2hPa).
3. Touch the WEATHER FORECAST section the third time,  button and  button will be flashing. Touch the  button or  button to set the storm threshold from 3-9hPa (default 4 hPa).





6.3.8 Pressure

1. Touch the PRESSURE section,  button and  button will be flashing. Touch the  button or  button to Shift the display between Absolute pressure and Relative pressure.
2. Touch the PRESSURE section again,  button and  button will be flashing. Touch the  button or  button to Shift the display unit between hPa, inHg and mmHg.
3. Touch the PRESSURE section the third time to set the Relative Pressure value. The  and  button will be flashing, **rel** icon will light up. Touch the  button or  button to change the value, hold the  button or  button for 3s to change the number in great step.
4. Touch the PRESSURE section the fourth time to set the pressure high alarm function, the  , **ON/OFF** and  button will be flashing, **HI AL** icon will light up. Touch the  button or  button to change the value, hold the  button or  button for 3s to change the number in great step. Touch the **ON/OFF** button to choose the alarm on or off (if alarm is enabled, the speaker icon will be turned on indicating the alarm function has been enabled).
5. Touch the PRESSURE section the fifth time to set the pressure low alarm function, the  , **ON/OFF** and  button will be flashing, **LO AL** icon will light up. Touch the  button or  button to change the value, hold the  button or  button for 3s to change the number in great step. Touch the **ON/OFF** button to choose the alarm on or off (if alarm is enabled, the speaker icon will be turned on indicating the alarm function has been enabled).
6. Touch the PRESSURE sections the sixth time to display maximum pressure record, to display maximum pressure, the recorded maximum value will be flashing; **MAX** icon will light up as well. Hold the maximum value for 3s, the maximum value will be reset to current reading.
7. Touch the PRESSURE section the seventh time to display minimum pressure record, to display minimum pressure record, the recorded minimum value will be flashing, **MIN** icon will light up as well. Hold the minimum value for 3s, the minimum value will be reset to current reading.















Note: when absolute pressure is selected, step 3 will be skipped since absolute pressure is selected for display.

6.3.9 Pressure bar graph









Touch the PRESSURE BAR GRAPH section and then press  or  to toggle the bar graph time scale between 12hrs or 24 hrs for pressure history.

6.3.10 Time







































1. Touch the TIME section,  button and  button will be flashing. Touch the  button or  button to set the time zone.
2. Touch the TIME section again,  button and  button will be flashing. Touch the  button or  button to Shift the 12/24 hours format.
3. Touch the TIME section the third time,  button and  button will be flashing. Touch the  button or  button to set the DST ON or OFF (this function is only available for WWVB version, while for DCF version, this feature is not activated).



Note: “DST OFF” indicates that the feature is off and the internal real time clock will not change times automatically. “DST ON” indicates that the feature is on and the internal real time clock will change times according to the DST time schedule automatically. Some locations (Arizona and parts of Indiana) do not follow Daylight Saving Time, and should select “DST OFF”.





4. Touch the TIME section the fourth time to set the hour, the  and  button will be flashing. Touch the  button or  button to change the value.
5. Touch the TIME section the fifth time to set the Minute, the  and  button will be flashing. Touch the  button or  button to change the value.

6.3.11 Date

1. Touch the DATE section,  button and  button will be flashing. Touch the  button or  button to shift between alarm time, date and week date.
2. Touch the DATE section again,  button and  button will be flashing. Touch the  button or  button to Shift between DD-MM format and MM-DD format for the date.
3. Touch the DATE section the third time,  button and  button will be flashing. Touch the  button or  button to set the year. Hold the  button or  button for 3s to change the number in great step.
4. Touch the DATE section the fourth time,  button and  button will be flashing. Touch the  button or  button to set the month. Hold the  button or  button for 3s to change the number in great step.
5. Touch the DATE section the fifth time,  button and  button will be flashing. Touch the  button or  button to set the day. Hold the  button or  button for 3s to change the number in great step.
6. Touch the DATE section the sixth time,  button and  button will be flashing. Touch the  button or  button to set the alarm hour. Hold the  button or  button for 3s to change the number in great step.
7. Touch the DATE section the seventh time,  button and  button will be flashing. Touch the  button or  button to set alarm minute. Hold the  button or  button for 3s to change the number in great step. Touch ON/OFF to enable or disable time alarm function.



6.3.12 Memory

1. Touch Memory section to activate history data toggle display,  button and  button will be flashing. Press  to toggle forward to see earlier weather history data together time stamp, press  to see later history weather data. When history data displayed, the corresponding time will be displayed at the time section area (History data saving interval can only be changed using the PC software that comes with this product, the default history data saving time interval is present to 30 minutes prior to shipment).
2. Touch Memory section again will trigger the memory clear procedure: the word of "CLEAR" will be flashing, the full memory usage icon will be flashing. Press and hold the memory full icon for 3 seconds will clear the memory.

6.4 PC Connection

As an important feature in addition to the display on the Touch Screen, the Weather Station allows the read-out of all measured and displayed time and weather data in form of complete history data sets on a PC.

6.5 Data Storage

For a comprehensive weather history, the Base Station allows the internal storage of up to 4080 complete sets of weather data with time and date. These data sets are being stored in ring buffer memory. In case the memory capacity of the Weather Station is exhausted the oldest data sets stored will be overwritten by the new ones entered.

6.6 Data Recall

Certain weather data or setting values can only be read out, processed, and displayed by means of a PC. Also the settings of the storing intervals from 5 minutes to 250 minutes for the storage of data sets can only be performed by means of a PC.

6.7 Connections and Software

The wiring between Weather Station and PC takes place by means of an included USB cable. The EasyWeather software package, also included in the shipping contents, must be installed on the PC. This software allows the display of all present weather data with graphic symbols. It also allows the display, storage, and printing of history data sets, whose volume exceeding the maximum 4080 data sets of the Weather Station is only limited by the capacity of the PC's main memory.

6.8 PC software installation

The installation of PCE-FWS 20 software is very simple: double click the setup.exe file and follow the steps popped up.

Make sure you are running the program under the administrator accounts of your windows PC platform. Otherwise the graphic function might not be working when graph display mode is needed to display all history data.

If you run the program for the first time, the current weather display will be displayed and at the sub line of the window, the program will show related information regarding the read of all history data into the PC. Please note however, when there is large amount of data is being uploaded, it will take a few minutes time before the system can respond to your setup settings. Otherwise it will display “read weather data fail” error message since the USB port is reading the data from the memory and the system is not able to respond any further job tasks.

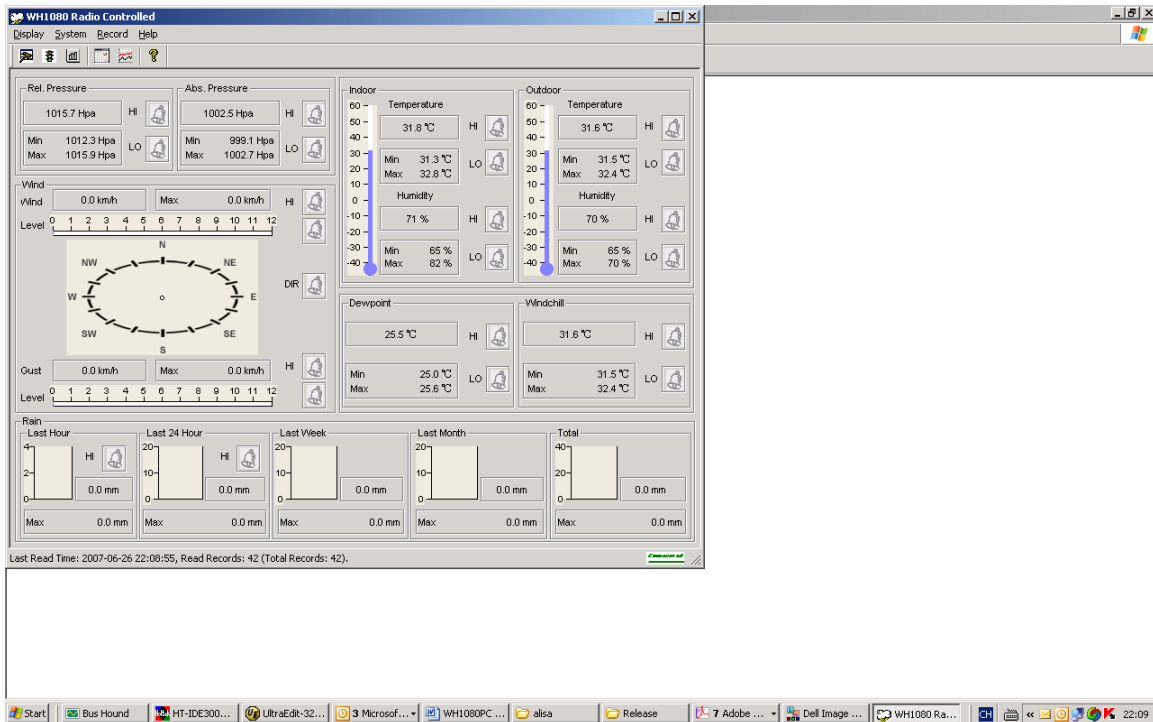

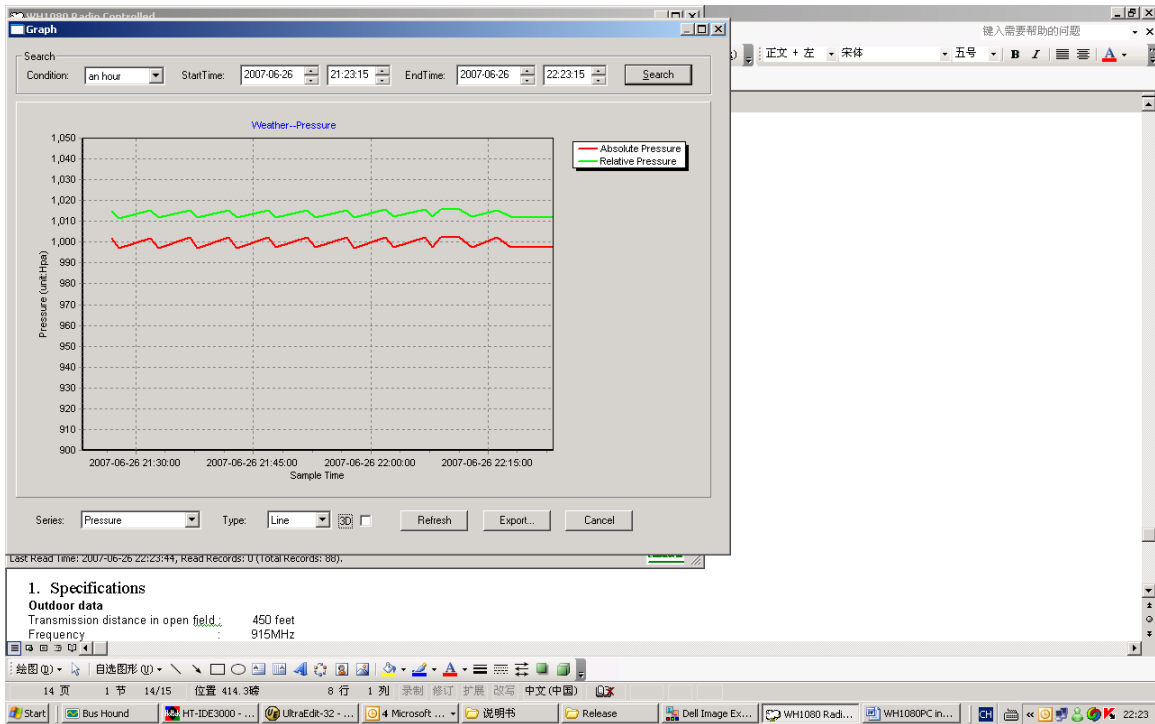

When memory is full, it will take about two minutes to upload all history data into PC and it takes another two minutes to process all history data for graphic display. Further detailed PC software user manual can be found from the help menu.

7 Software

7.1 System Requirements

To install the "EasyWeather" software onto your PC, the minimum requirements are as follows:
 Operating System: Windows NT4 (Service Pack >= 6a), Windows 2000, Windows XP, Windows Vista.
 Internet Explorer 6.0 or above
 Processor: Pentium III 500 MHz or above
 Memory: at least 128MB, 256MB recommended
 CD-ROM Drive
 Base Station and PC must be connected by USB cable

7.2 Installation of the "EasyWeather" Software

The Base Station and the Outdoor Sensors must be connected and checked for correct function (see **Setup**).

After successfully checking proper function of the weather station, install the "EasyWeather" software as follows:

1. Switch on your PC and insert the CD-ROM into the CD-ROM Drive.
2. Double click "Setup.exe"
3. Select the language and click next
4. Click next and select the storage location
5. Click next to install the programme
6. Press ok to finish the installation process
7. The programme is to be found under "Start—All Programs—EasyWeather"

Note: The user should be aware, that to fully access the graphic functions, they need to have administrative rights for the computer.

7.3 Basic Settings of the PC Software

After the start-up of "EasyWeather.exe" programme, the following window will appear on the PC screen:

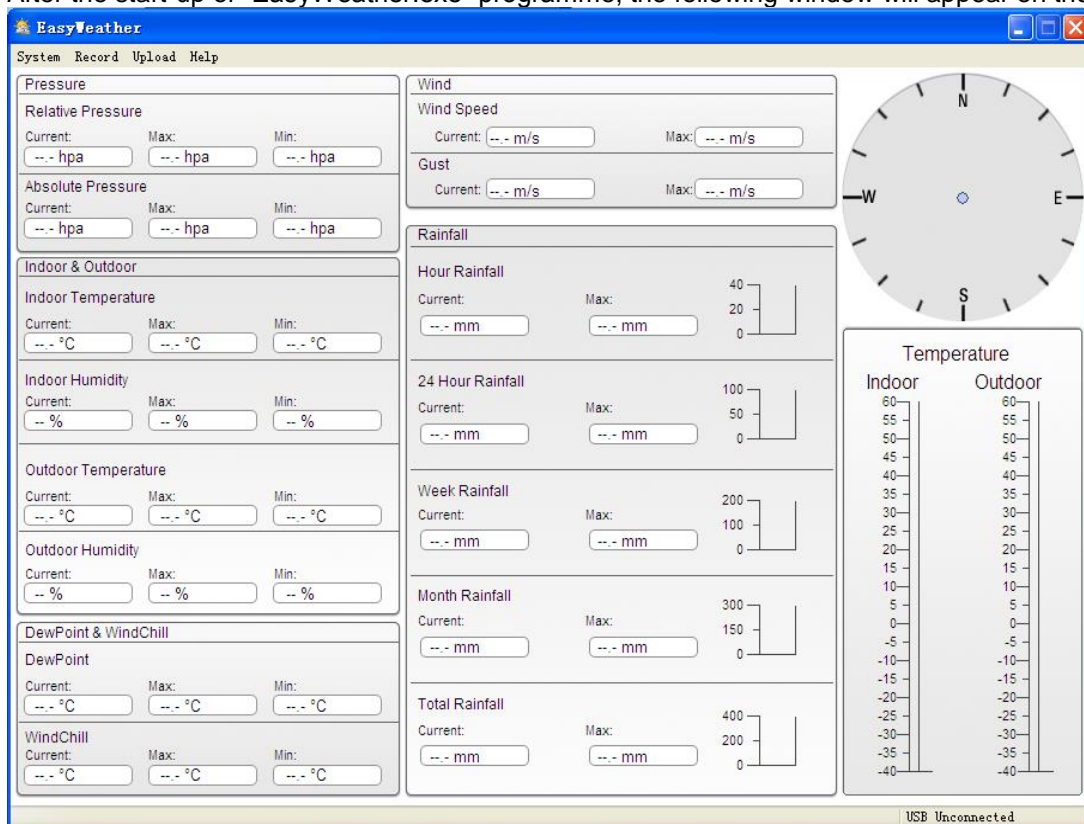

The settings from the base unit are transferred to the PC software. Once the settings of the base unit have been completed, then no other setting changes need to be made on the PC software. However it is easy to change the settings on the PC software and transfer these to the base station. (The settings will be updated on the base station in the next full minute)

7.4 System menu

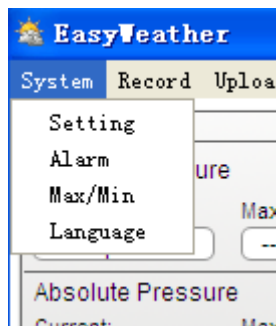

7.4.1 Basic setting

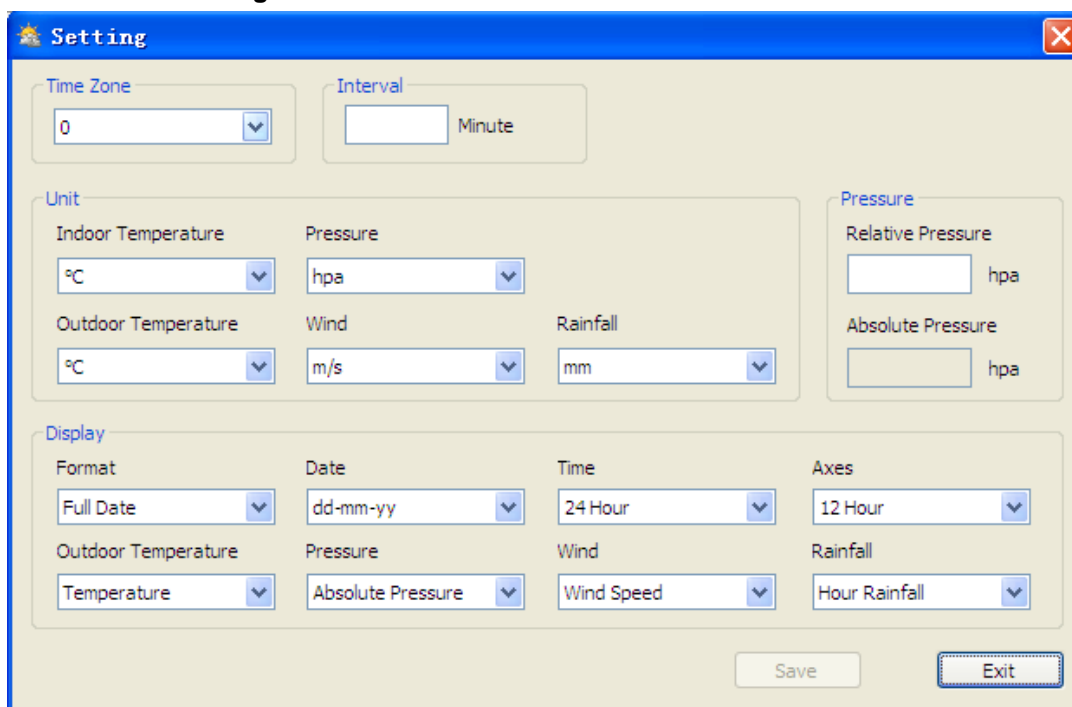

This section is used to set the language, the basic element, the units and to switch the corresponding warning function on or off. Press the “Save” button to confirm the settings.

7.4.2 Alarm settings

This section is used to set the desired time and to set a higher or lower warning value. Press the “Save” button to confirm the settings. If you do not need to change any of the settings, press “Cancel” and exit.

7.4.3 Max-Min Display

This section is used to display the recorded min and max value values with a time stamp. Min/Max reset can only be carried out on the base station.

If you would like to start a new weather history record, press the “Clear Data” button and all the recorded data will be deleted.

If you would like to keep a backup history file before deleting all weather data, rename the “EasyWeather.DAT” file, to “Jan-07.DAT” or copy the file into another folder.

7.5.2 Graphic Display

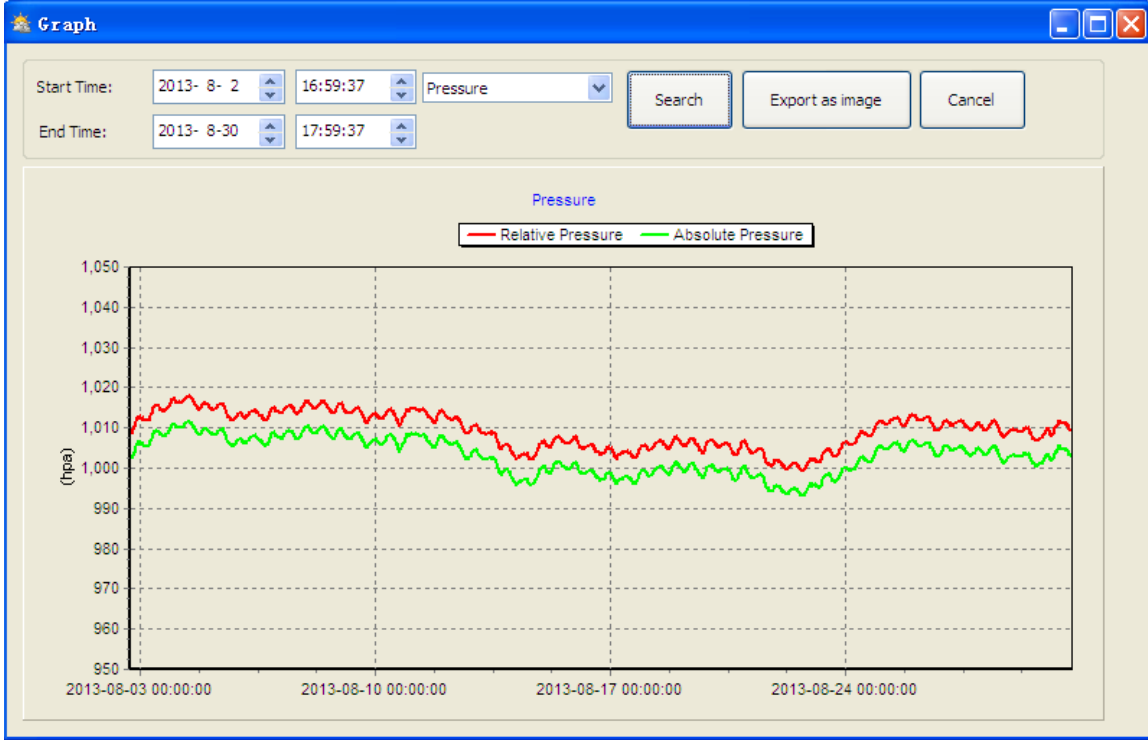

In this section, the saved data can be viewed in graph format. If you want to view more details, use the mouse to select the area and the display will automatically be updated in more detailed scale:

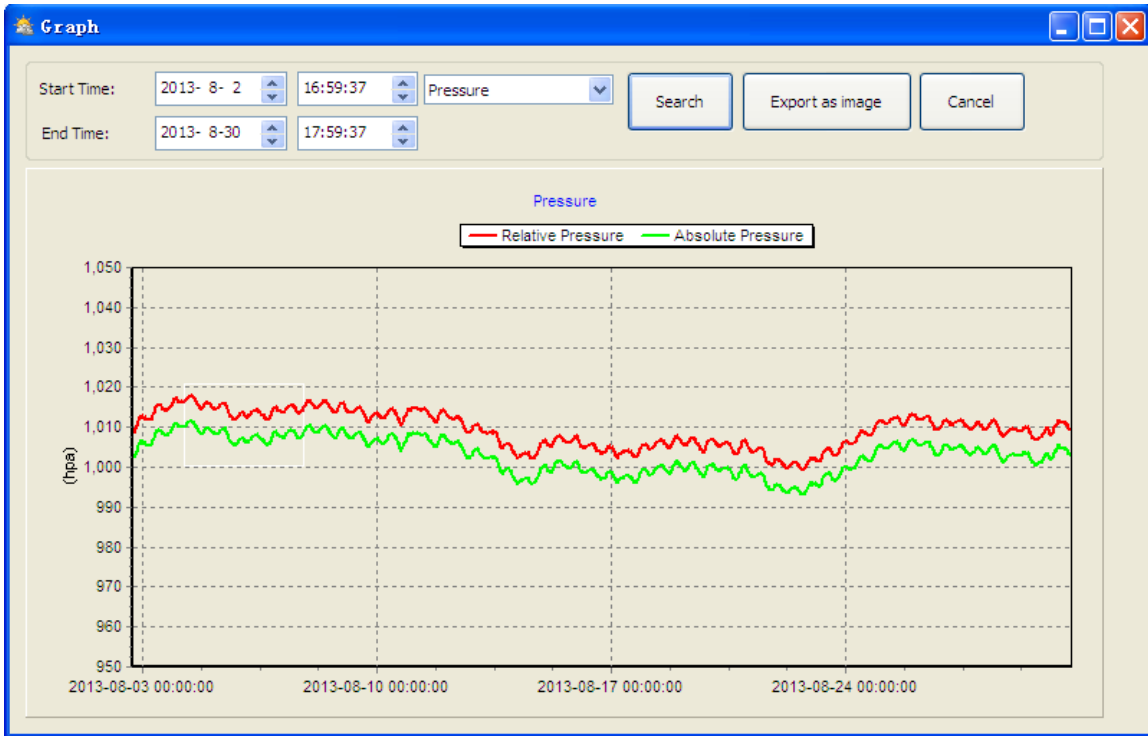

The y-axis can be changed by scrolling the mouse wheel or selecting an area.

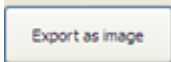
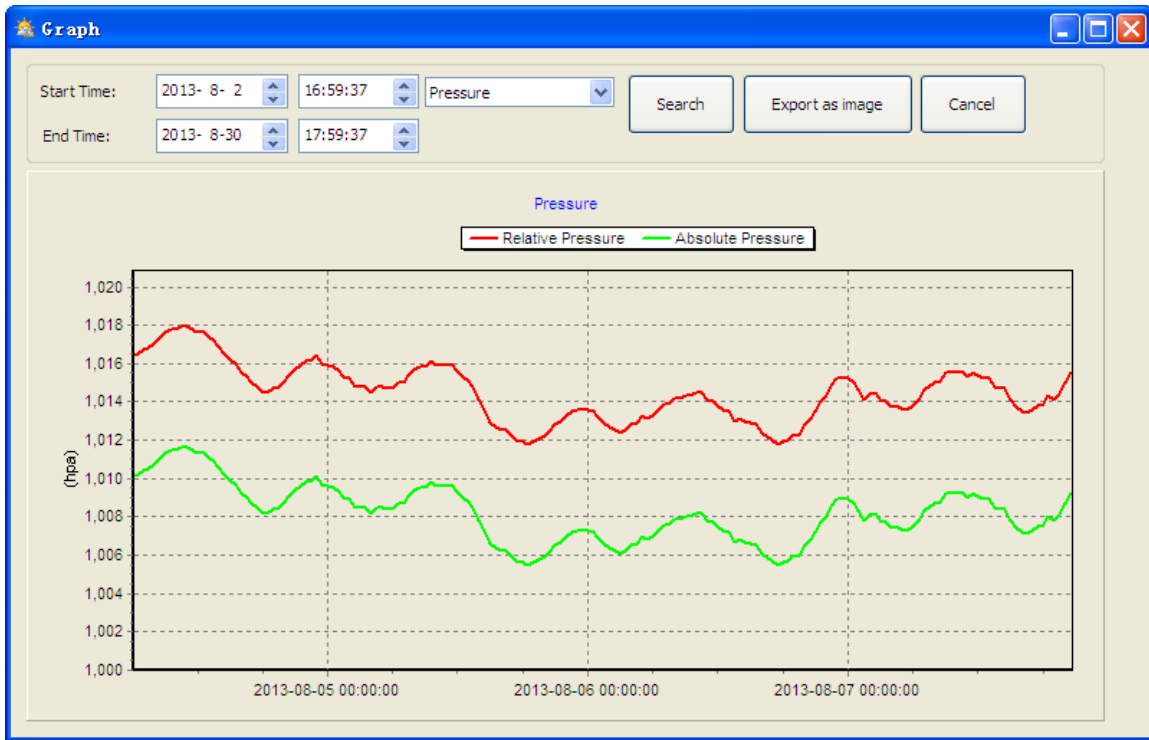

The  button exports the graph to an image.

7.6 Troubleshooting: Graphs are not being displayed

This is the most encountered problem with this software. To make sure the graph will be displayed, proceed as follows:

1. Find the folder in which the “EasyWeather.exe” file is located.
2. Create a file name “reg_graph.bat” file with word pad or notepad editor programme (Make sure that Windows saves the file with the correct ending and not as “reg_graph.bat.txt” – the file name in front of the point is not relevant).
3. Give in “regsvr32 easyweather.ocx” (without quotation marks) into the text editor and save the file.
4. Double click on the created file – The following message confirms that the command has been successfully executed.

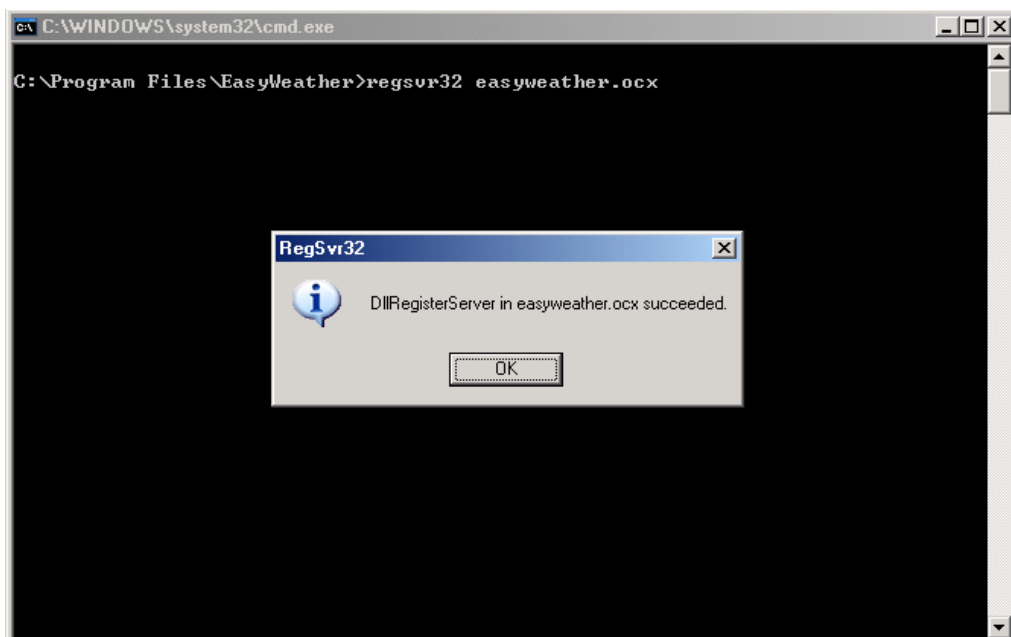

7.7 Data upload

Note: This function is available from Version 8.3. The current version is available for download on the PCE Homepage.

7.7.1 Upload according to weather underground

The saved measurement data can be uploaded on www.wunderground.com. Register on www.wunderground.com. Then enter your password and ID.

The 'Upload' dialog box contains the following fields and options:

- Website:** A dropdown menu with a blank selection.
- Server:** A text box containing 'www.wunderground.com' and '(Custom)' below it.
- Type:** A dropdown menu set to 'php'.
- Port:** An empty text box.
- Upload Type:** A dropdown menu set to 'Customize'.
- ID:** An empty text box.
- PassWord:** An empty text box.
- Auto Upload
- Buttons:** 'Save' and 'Cancel' buttons.

The 'Upload' dialog box is filled out with the following values:

- Website:** 'www.wunderground.com'
- Server:** 'rtupdate.wunderground.com'
- Type:** 'php'
- Port:** '80'
- Upload Type:** 'Customize'
- ID:** (empty)
- PassWord:** (empty)
- Auto Upload
- Buttons:** 'Save' and 'Cancel' buttons.

7.8 Special notes to time synchronization between PC and base station

The PC software obtains its own time scale through the time interval marker from the base station. To set the time scale correctly, the time on the PC and the base stations time have to be set identically. This prevents weather data being overwritten or omitted. If the saved weather recordings on the base station are deleted manually, then the weather recordings since the last saving will be permanently lost.

It is recommended that the recorded weather data should be saved periodically on the PC before the memory of the base station is fully used up (the LCD display shows 100% when full).

8 Disposal

For the disposal of batteries, the 2006/66/EC directive of the European Parliament applies. Due to the contained pollutants, batteries must not be disposed of as household waste. They must be given to collection points designed for that purpose.

In order to comply with the EU directive 2012/19/EU we take our devices back. We either re-use them or give them to a recycling company which disposes of the devices in line with law.

If you have any questions, please contact PCE Instruments.



9 Contact

If you have any questions about our range of products or measuring instruments please contact PCE Instruments.

9.1 PCE Instruments UK

By post:

PCE Instruments UK Ltd.
Units 12/13 Southpoint Business Park
Ensign Way, Southampton
Hampshire

United Kingdom, SO31 4RF

By phone:

02380 987 035

9.2 PCE Americas

By post:

PCE Americas Inc.
711 Commerce Way
Suite 8
Jupiter
33458 FL
USA

By phone:

561 320 9162