



Manual

Balanza dosificadora PCE-ABZ 200C



1. General description.....	3
2. Completeness.....	3
3. General view	3
Front view:.....	3
Rear view:	4
4. Keys and indicators	4
5. Technical Data	5
6. Security rules.....	5
7. Preparations – working environment	7
8. Preparation – the balance.....	8
9. Operation principles.....	8
10. Testing and calibration	9
11. External calibration / calibration options	9
Operations sequence:	10
12. Internal calibration (autocalibration)	11
Internal calibration settings (time intervals and temperature changes)	11
13. Connecting a balance to a computer or a printer	12
1. Standard mode:.....	12
2. Automatic mode:.....	12
14. Special functions description.....	14
15. Legend.....	14
16. Normal weighing.....	14
17. Weighing with tare.....	14
18. Autozeroing (Aut ...).....	15
19. Pieces counting (PCS)	15
20. Serial port setting (rS-232CS).....	16
21. Date and time setting (F.-dAt).....	17
22. Maintenance and repairs of small defects	17
Error communicates:	18

1. General description

PCE-ABZ...C series balances are destined for high accuracy weighing in laboratory practice.

Balances are equipped with an internal calibration system for proper accuracy control during operation. The user should also own weight standard of OIML F2 or F1 class for periodical control of the balance (weight value stated in Technical Data sheet) - available separately.

All balances are metrologically tested - calibration on demand.

2. Completeness

A standard set consist of:

1. Balance
2. Tin floor plate and pan ring,
3. Pan support and pan
4. Feeder ZN 12V/500mA,
5. User Manual,
6. Guarantee card.

3. General view

Front view:

- 1 – pan
- 2 – support pan
- 4 – display LCD
- 5 – keyboard
- 6 – legs
- 7 – water-level

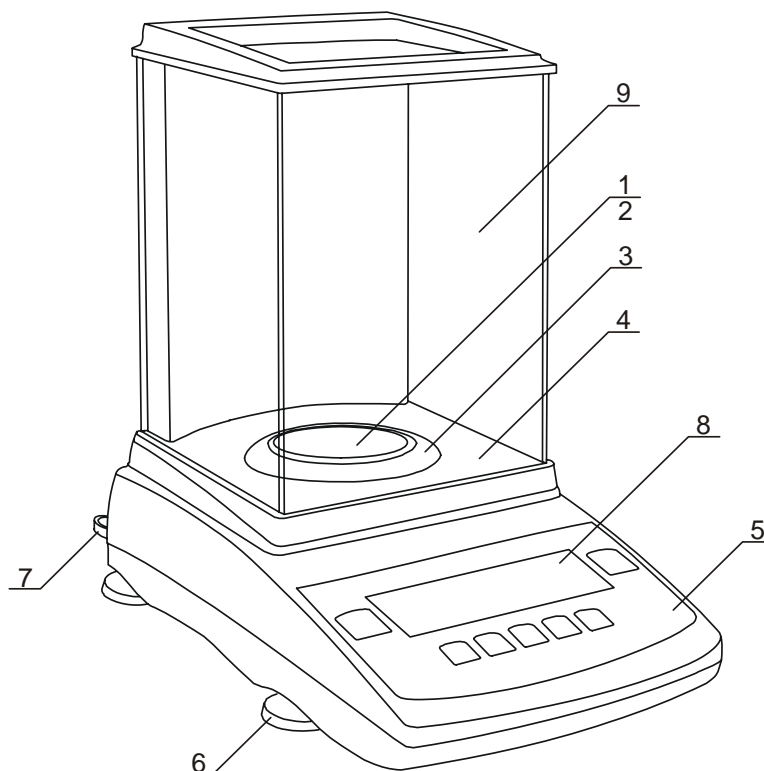



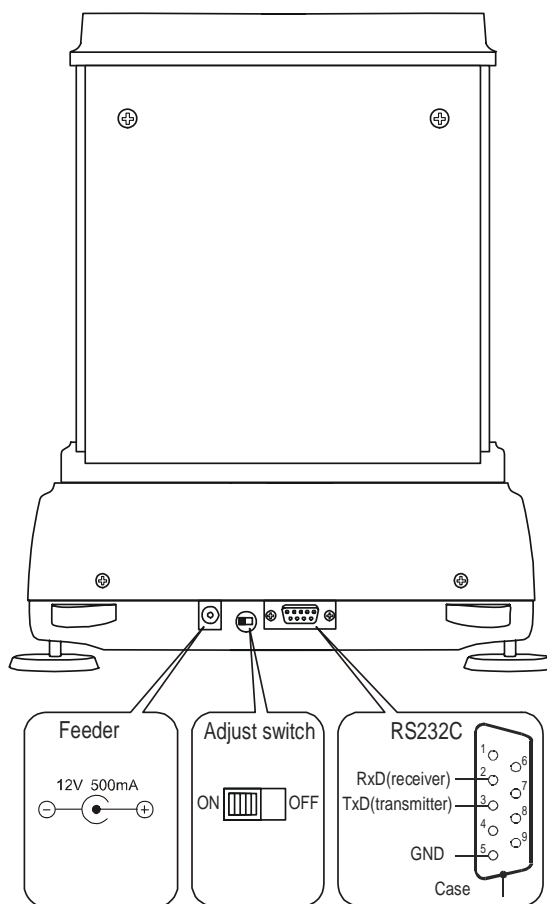

Rear view:

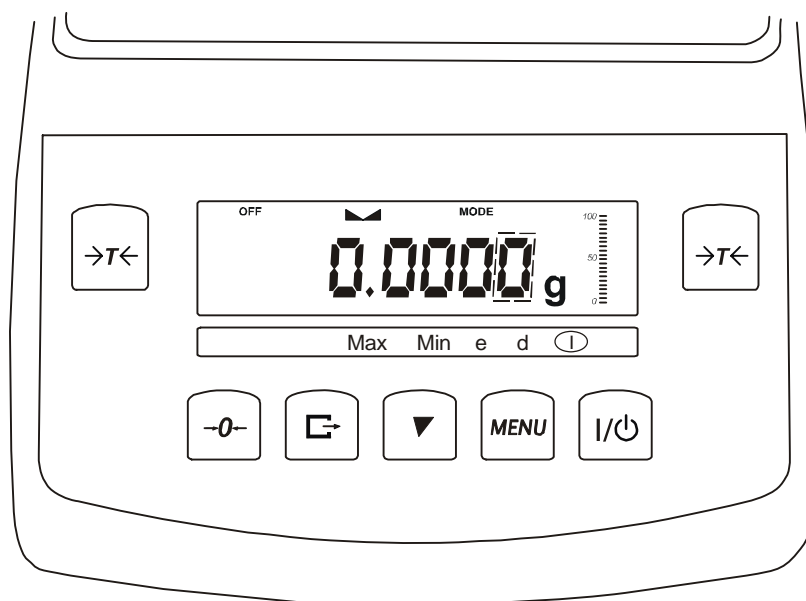

4. Keys and indicators



- | | | |
|--------------------|--|--|
| key | →T← | - tare (subtract package weight from weighed mass) |
| key | →0← | - numeric key / zeroing (balances for direct sale use only), |
| key |  | - numeric key / data output (print / transmission), |
| key |  | - numeric key / internal calibration on and off, |
| key | Menu | - numeric key / Menu, |
| key | I/  | - switch-on/switch-off (standby), |
| indicator |  | - result stabilisation, |
| bar indicator | | - load indicator 0 ÷ 100%, |
| indicator | OFF | - stand-by mode, |
| Max, Min, d, e, II | | - metrologic parameters and accuracy class. |

5. Technical Data

Type		
Capacity (Max)	100g	200g
Min load (Min)	10mg	10mg
Reading unit (d)	0,1mg	0,1mg
Verification unit (e)	1mg	1mg
Tare range	-100g	-200g
Accuracy class	I	
Working temperature	+18 ÷ +30 °C	
Weighing time	<8s	
Pan dimension	φ90mm	
Balance base dim. (including legs)	215(235)x345x350mm	
Weighing chamber dimensions	175x140x230mm	
Power	~230V 50Hz 9VA / =12V 300mA	
Balance weight	6,5kg	
Calibration weight (OIML)	E2 100g	E2 200g

6. Security rules

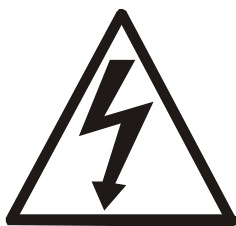

To avoid electrical shock or damage of the balance or connected peripheral devices, it is necessary to follow the security rules below.

- All repairs and necessary regulations can be made by authorised personnel only.
- To avoid fire risk use a feeder of an appropriate type (supplied with the balance). Pay attention that supply voltage is compatible with specified technical data.
- Do not use the balance when its cover is opened.
- Do not use the balance in explosive conditions.
- Do not use the balance in high humidity.
- If the balance seems not to operate properly, unplug it from the mains and do not use until checked by authorised service.



According to legal regulations it is forbidden to dispose electronic equipment in waste containers.

- Please return wasted balance to the point of purchase or other company specialised in recycling of wasted electronic components.

7. Preparations – working environment

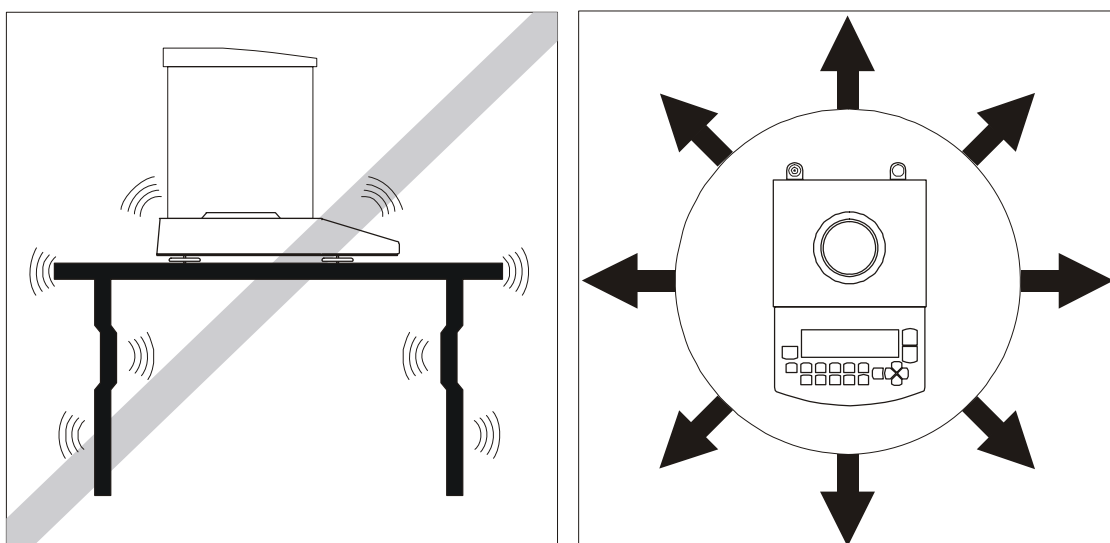
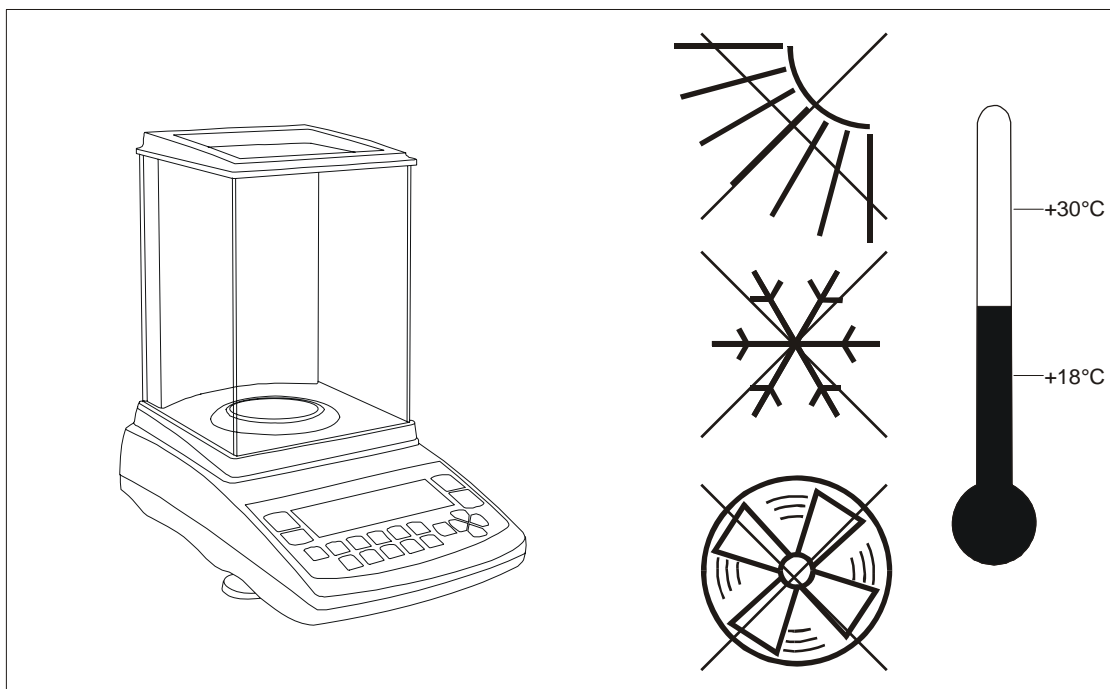

When choosing a location to set up the balance, remember the following rules to ensure proper working conditions and user-friendly operating:

- Setup the balance on an even, flat surface leaving necessary room for easy access.
- Maintain proper working temperature.
- Avoid strong air drafts, vibrations, dust, big temperature changes and humidity over 75%.
- Avoid locations with extreme heat radiation and electromagnetic PCE-ABZ 100C or metric PCE-ABZ 200C fields.

8. Preparation – the balance

1. Take the balance and supplied accessories (a feeder, pan elements) out of the box.
2. Place the balance on a stable ground not affected by mechanical vibrations and airflows.
3. Level the balance with rotating rear legs **6** so that the air bubble in water-level **7** at the back of the balance is in the middle.
4. Place tin floor plate **4** and the pan ring **3** in the weighing chamber and gently put on the pan support **2** and finally the pan **1**.
5. Plug a feeder to the power socket at the back of the balance.

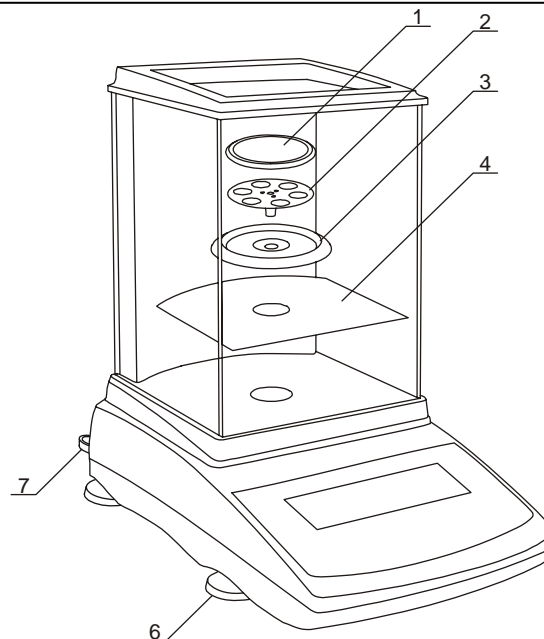

Moisture in the air may condense on the surface of the balance when transferred to the warmer environment. In this case leave the balance for at least 4 hours unplugged from the mains for conditioning to avoid wrong operating or damage of the balance.

Leave the pan empty and plug the feeder to the mains. At the end of self-tests, the balance displays zero indication and is now ready to work.

9. Operation principles



Do not overload the balance more than 20% of maximum load (Max). Do not press the pan with a hand.



Before transportation take off the pan (move it slightly and lift it up) and the pan base and preserve from any damages.

1. To ensure proper weighing accuracy the balance is equipped with internal calibration system. The system automatically calibrates the balance every 2 hours and with temperature changes more than 1°C (values modification possible) without user intervention. When the balance is moved to another localisation remember to level the balance and proceed with internal calibration.
2. Weighed sample should be placed in the centre of the pan.
3. In balances equipped with 0 key and with d=e, make sure that zero indicator is displayed. If not, press 0 key and wait until zero indication and zero indicators appears. In other balances the key does not operate.
4. The balance is equipped with a tare equal to its range. To tare the balance press →T← key (left or right). Storing a tare value does not extend measuring range, but only subtracts it from a load placed on the pan. To make weight control easier and to avoid range overdrawn, the balance is equipped with a load indicator (graduated in percentages).
5. Weighing result should be read when the indicator "▲" lights, which signals stabilisation of a result.
6. When the balance is not used but it is necessary to be ready to work immediately, it can be switched off by pressing I/O key. The balance reading system is then switched off to "standby" mode (signalled by the indicator "OFF"). To switch the balance on press I/O key. The balance is immediately ready to operate maximum accuracy (after self tests).
7. The mechanism of the balance is a precise device, sensitive to mechanical strokes and shocks.

8. The balance should not be used to weigh aerometric PCE-ABZ 200C materials due to accuracy decrease.

10. Testing and calibration

To ensure reliable results it is advised to check balance accuracy with an object of precisely known weight before and after each measuring session.

To check a balance with EC verification use a weight standard as stated in Technical Data table for specific balance type (or of better accuracy) with valid calibration certificates. In case permissible error is exceeded please contact an authorised service.

11. External calibration / calibration options

Calibration with external weight standard in verified balances should be performed in case balance indications exceed permissible error. To calibrate the balance a service centre should use calibration weight as stated in Technical Data table (or of better accuracy) with valid calibration certificate.



External calibration in verified balance should be performed in authorised PCE services, as it is possible only after removing protective seals. In this case the validity of the verification is void and the balance must be re-verified by the nearest Notified Body or at the place of installation.

In balances with EC verification calibration function is blocked for the user. It is only possible to print calibration report useful for routine balance check-through.

The report printout example

Date: ...	Time: ...
CALIBRATION REPORT	

FACTORY NUMBER:	...
PROGRAM NUMBER:	...
CALIBRATION PRIMARY MASS:	...
CALIBRATION MASS:	...
DIFFERECE MASS:	...

- Internal weight value registered during factory calibration.

- Internal weight value registered during last calibration.

- Difference between internal weight values: factory value–current value (PCE-ABZ 200C diosis).

Operations sequence:

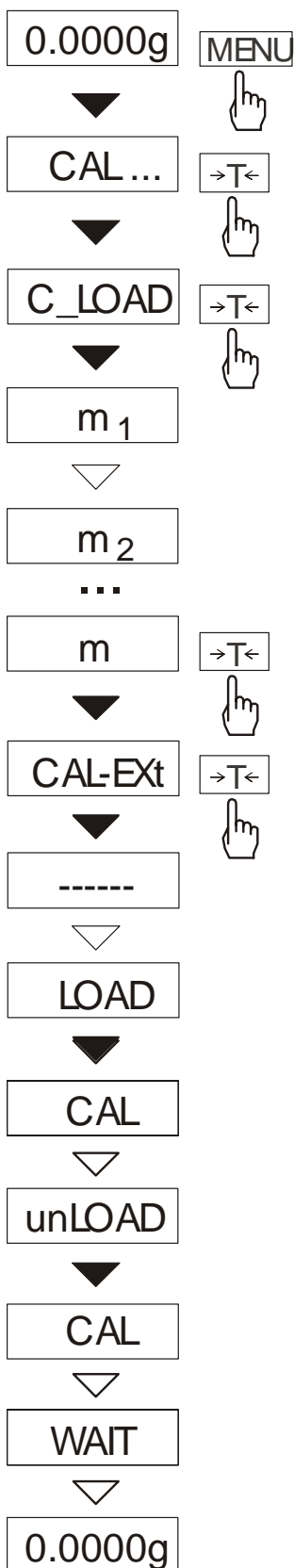
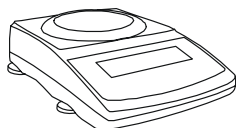

Press MENU to call functions and press →T← to choose calibration "CAL ..".

Press →T← to choose "C_LOAD" and calibration weight value.

Press →T← to choose "CAL_EXT".

Wait until zeroing process is finished.

When "LOAD" communicates put a calibration weight on the pan.

Wait until calibration process is finished.

When "unLOAD" communicate appears remove the calibration weight from the pan.

Wait until internal calibration is finished.

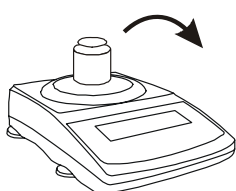
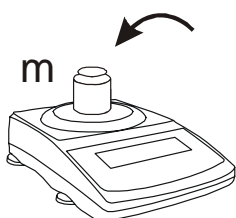

12. Internal calibration (autocalibration)

Internal calibration is performed automatically after each start-up, also in defined time intervals and temperature changes.

To calibrate the balance with internal weight, simply empty the pan and press key. The beginning of internal calibration is signalled with -CAL- communicate on the display.

Internal calibration settings (time intervals and temperature changes)

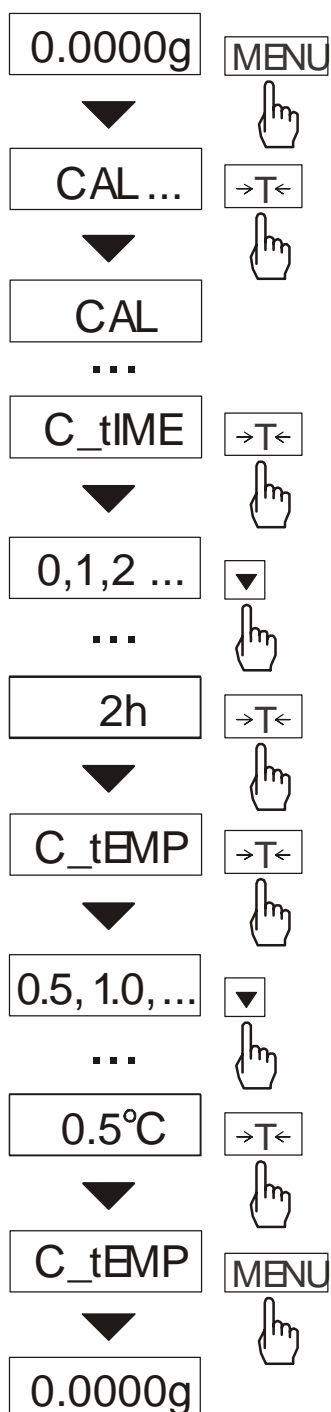
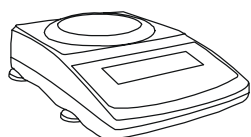

Press MENU to call functions and press $\rightarrow T \leftarrow$ to choose calibration "CAL ..".

Calibration function options:
 -CAL - calibration (see chapt. 11).
 -C_LOAD – calibration weight.
 -C_time - time interval setting.
 -C_tEMP - temp. change setting.
 -Report - calibration report.

Press $\rightarrow T \leftarrow$ to choose option (to accelerate press several times) and value.

13. Connecting a balance to a computer or a printer

The balance may send data to a computer or a printer through RS232C port.

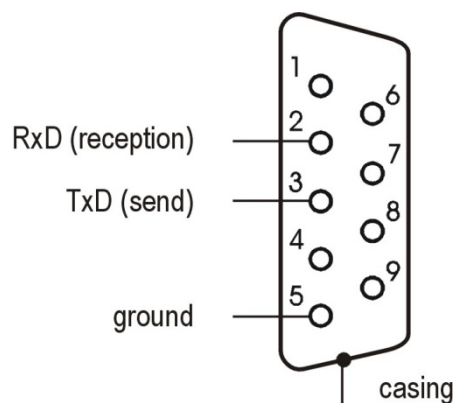

When cooperating with the balance, a computer should be equipped with a program which enables processing data from the balance.

AXIS offers computer programs cooperating with balances. There is also a freeware program for testing a serial port of the balance.

We also offer:

- Computer wires
- Thermal printers
- Label printers

Serial port working modes:

Standard mode

The balance sends weighing result after initialising signal from a computer or after pressing  key.

Automatic mode (when cooperating with a printer)

The balance sends data automatically after result stabilisation; next transmission is possible after removing previously weighted sample.

To select serial port working mode use LPt function (see further part of the manual).

Standard transmission parameters: 8bits, 1stop, no parity, 4800bps. To change transmission parameters use rS function (see further part of the manual).

Data transmission protocol description (Long protocol)

1. Standard mode:

Computer→Balance: initialising signal S I CR LF (53h 49h 0Dh 0Ah)

Balance→Computer: balance indication in the following format (16Bytes)

Byte 1	- sign or space
Byte 2, 11 and 14	- space
Byte 3÷4	- digit or space
Byte 5÷9	- digit, decimal point or space
Byte 10	- digit
Byte 12	- k, l, c, p or space
Byte 13	- g, b, t, c or %
Byte 15	- CR (0Dh)
Byte 16	- LF (0Ah)

2. Automatic mode:

After stabilisation of each weighing result, excluding zero indication, the balance sends 3-digit successive measurement number and a weighing result.

To clear the measurement counter chose automatic mode once more (see LPt function description for further details).

Sample printout:

1	1250.5 g
2	1250.0 g
3	1250.1 g
	...

When dAt function is active, a printout is extended with current date and time:

1	1250.5 g	2005.04.20	8:05
2	1250.0 g	2005.04.20	8:05
3	1250.1 g	2005.04.20	8:06

Connection cable WK-1 (balance – computer / 9-pin):

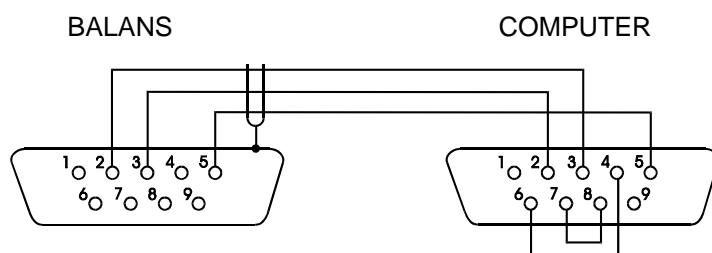

Connection cable WD-1 (balance - KAFKA printer):

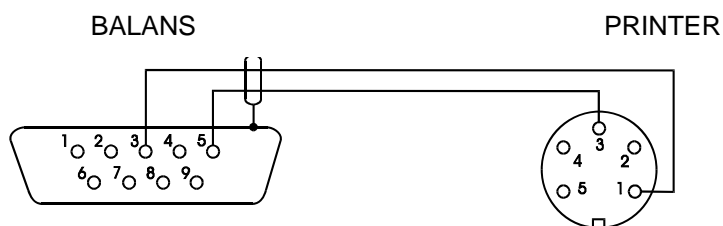

KAFKA printer internal switches set-up:

SW-1	SW-2	SW-3	SW-4	SW-5	SW-6	SW-7	SW-8
on	off	on	off	off	on	off	off

It is possible to use a transmission protocol other than LonG on customer's demand, e.g. Farb protocol used for cooperation with automatic paint mixer: continuous transmission (Send option), transmission speed 2400bps, additional "+" sign in first byte.

14. Special functions description

All balances, beside basic functions like weighing and tare, are equipped with a set of additional functions: calibration, pieces counting, auto zeroing and serial port working mode setting. Other functions: recipe ingredients summing, density calculation and other special functions can be enabled as an option on customer request (described in additional brochure when ordered).

To display all available function, enter Function Menu with MENU key. Functions are displayed: Aut..., PCS, CAL..., rS-232C, DATE..., etc. When special functions are displayed, MODE indicator is displayed.

To make clear how to manage with each function, in further part of instruction descriptions are replaced with pictures.

15. Legend



123.4 g



- press a key
- balance indication
- forced change
- automatic change

16. Normal weighing

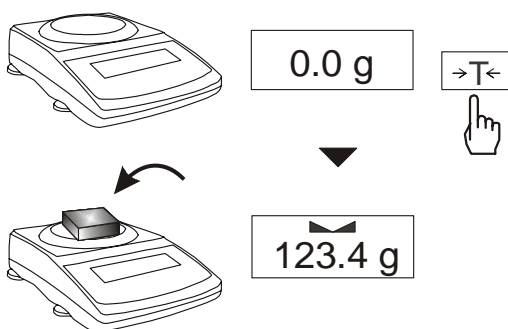

When the pan is empty and indication is different than zero press →T← key.

Weighing result should be read when the indicator "▲" lights.

17. Weighing with tare

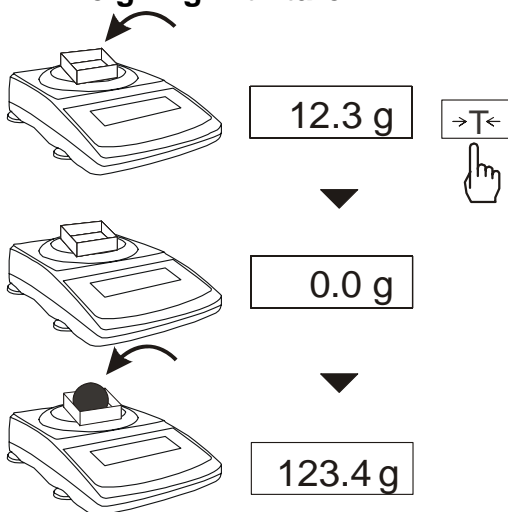

The balance is equipped with tare equal to its range.

18. Autozeroing (Aut ...)

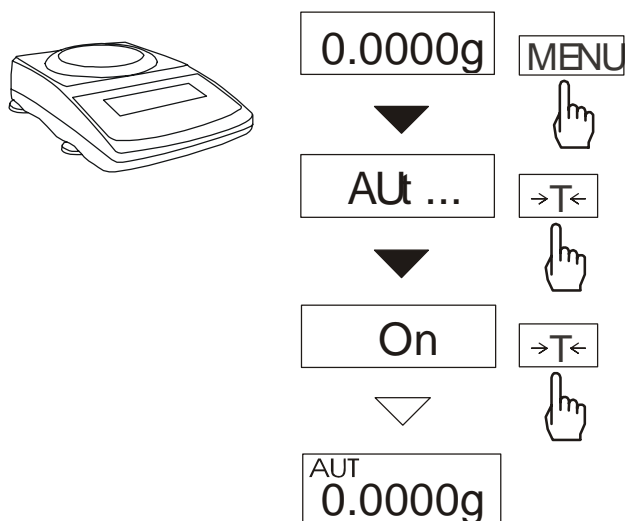

When "Aut" function is activated, the balance automatically ensures stable zero indication if the pan is empty or if zero indication was acquired by pressing →T← key.

Function has options:

- On – function is activated
- OFF – function is not activated
- Correct - maximum zero flow to be automatically corrected
- out – exit of setting

Changing value of maximum zero flow:

- ▼ - Next digit,
- ⇨ - Decimal point,
- T← - Next position,
- MENU - end.

Note: Autozeroing function is activated automatically for 10 min. after switching-on.

19. Pieces counting (PCS)

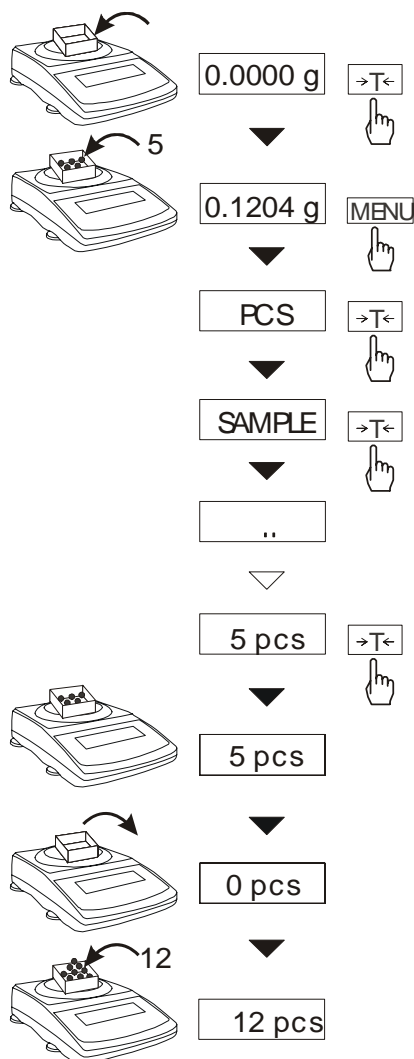

This function enables to count identical pieces, e.g. turnbuckles or buttons.

A measurement is performed in two phases:

- First phase - single piece weight calculation on the basis of defined pieces amount (5, 10, 20, 50, 100, 200 or 500 pieces),
- Second phase – pieces counting.

It is advised that single piece weight is not less than one reading unit and sample weight used in first phase is bigger than 100 reading units.

To leave function press MENU key and then with →T← key chose "PCS" and "OFF".

Note:

Err-PCS communicate signalises that a sample was not put on the pan. The same communicate appears if single piece weight is less than one reading unit (it is possible to count pieces but measuring error is bigger).

To chose previously used pieces amount select ".." in first phase.

During pieces counting T key function does not change.

20. Serial port setting (rS-232CS)

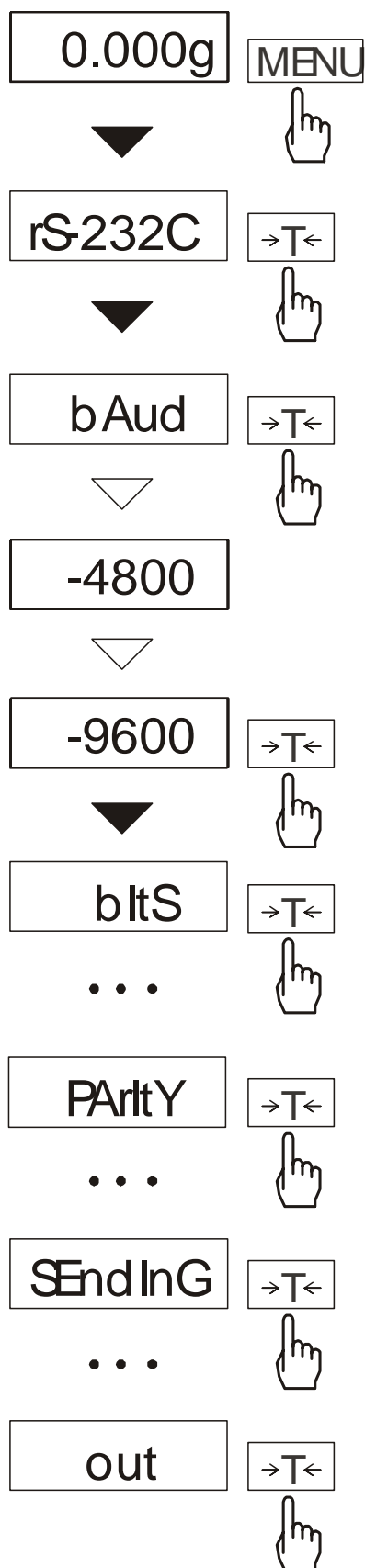

Function allows to set RS232C parameters:
 velocity (bAud: 1200, 4800, 9600),
 bits (bit: 7, 8),
 parity control (PARItY: 0, 1; Odd: 0, 1),
 Continuous transmission – without key , 10 times per second (SEnd: 0, 1).

Press MENU to choose "rS-232C", press →T← to choose parameter.
 Set parameter and choose "out" to finish.

21. Date and time setting (F..-dAt)

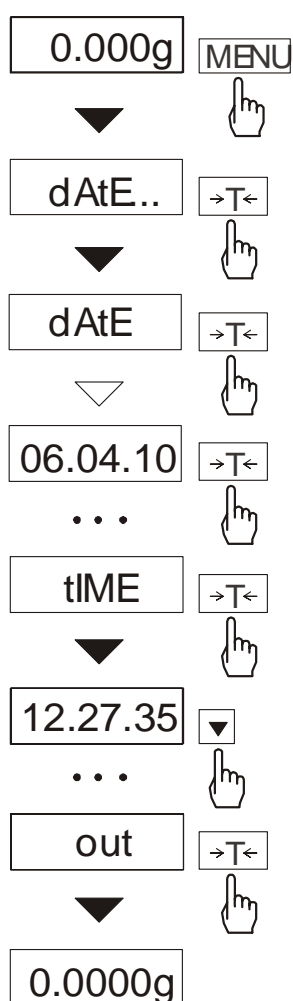

Function puts date and time into printout and allows to set actual.

Function has options:
dAtE – date setting,
tIME – time setting.

Changing value:
▼ - next digit,
→T← - next position,
MENU - end.

22. Maintenance and repairs of small defects

1. The balance should be kept clean.
2. Take care that no dirt gets between a casing and the pan. If found any, remove the pan (lift it up), remove dirt and then replace the pan.
3. In case of improper operation caused by short-lasting power supply decay, unplug the balance from the mains and then plug it again after few seconds.
4. To calibrate the balance contact nearest service.
5. It is forbidden to make any repairs by unauthorised persons.
6. To repair the balance, please contact our nearest service.

Error communicates:

Communicate	Possible cause	Remedy
C-1 ... 6 (over 1 min.)	selftests failed	if displayed more than 1 minute, contact an authorised service
L	pan missing	put the pan on
	mechanical damage	contact an authorised service
H	overloading	remove the load from the pan
	mechanical damage	contact an authorised service
 indicator does not appear	unstable ground vibrations air flows	place the balance on a stable ground not affected by mechanical vibrations and airflows
	balance damage	contact an authorised service
-----	taring in progress	as above

In this direction will find a vision of the measurement technique:
<http://www.industrial-needs.com/measuring-instruments.htm>

NOTE: "This instrument doesn't have ATEX protection, so it should not be used in potentially explosive atmospheres (powder, flammable gases)."