



Tursdale Technical Services Ltd
Unit N12B
Tursdale Business Park
Co. Durham
DH6 5PG
United Kingdom
Phone: +44 (0) 191 377 3398
Fax: +44 (0) 191 377 3357
info@tursdaletechnicalservices.co.uk
<http://www.industrial-needs.com/>

Manual PCE-FM50



TABLE OF CONTENTS

1 FEATURES.....	1
2 SPECIFICATIONS.....	1
3 FRONT PANEL DESCRIPTIONS	4
3-1 Universal Sensing Head.....	4
3-2 LCD Display.....	4
3-3 Fast Indicator.....	4
3-4 FAST/SLOW Button.....	4
3-5 LCD Reverse Display Button.....	4
3-6 Zero Button.....	4
3-7 g/oz/Newton Unit.....	4
3-8 Power Off/On/Peak Hold.....	4
3-9 Mounting Holes/fixing Screws.....	4
3-10 Battery Cover/Compartment.....	4
3-11 Flate-head Adapter	4
3-12 Cone Adapter.....	4
3-13 Chisel Adapter	4
3-14 Hook Adapter	4
3-15 120 mm Extension Rod.....	4
3-16 LCD Back Light Button.....	4
3-17 DC 9V Power Adapter Input Socket.....	4
3-18 RS-232 output terminal.....	4
4 MEASURING PROCEDURE	5
4-1 Preparations For Measurement	5
4-2 Normal Measurement	6
4-3 Peak Hold Measurement	7
4-4 LCD Back light On/Off.....	7
5 BATTERY REPLACEMENT	8
6 RS232 PC SERIAL INTERFACE.....	8
7 MOUNTING HOLES & OPTIONAL TEST STAND.....	10
8 APPLICATIONS.....	11

1. FEATURES

- * Large LCD display with back light.
- * 5,000 g, wide capacity, high resolution, high accuracy, high repeatability.
- * 3 kind display unit : g, oz, Newton.
- * Tension & compression capability .
- * Peak hold (Max. load) can be held in display during make tension or compression measurement.
- * Zero button can operate both for normal measuring & the " peak hold " operation.
- * Full capacity zero (tare) control capability.
- * Fast/Slow response time push button.
- * Positive or reverse display direction select.
- * Full line accessories (adapters) are included.
- * Hand held & stand mounted gauges are available.
- * Low power consumption gives long battery life.
- * Build in low battery indicator.
- * Microprocessor circuit & exclusive load cell transducer.
- * Over load protection.
- * RS-232 computer interface
- * Built-in DC 9V power adapter input socket.
- * Professional test stand (optional).

2. SPECIFICATIONS

Display	LCD (Liquid crystal display). 5 digits, 16 mm (0.63") digit size. Back light.
---------	---

Display Direction	Positive or Reverse direction, select by the push button on the front panel.
Function	Tension & Compression (Push & Pull). Normal force, Peak hold (Max. load).
Peak hold	Will freeze the display value of the Peak load (Max. load).
Zero	Zero button can be operated both for "normal force" or "peak hold" operation
Unit select	g/oz/Newton
Measure Capacity	5,000 g/176.40 oz/49.03 Newton.
Resolution	1 g/0.05 oz/0.01 Newton.
Min. Display	3 g/0.10 oz/0.03 Newton.
Accuracy	$\pm (0.4 \% + 1 \text{ digit })$, within $23 \pm 5^{\circ}\text{C}$. <i>* Under the test weight on 3000 g & 5000 g.</i>
Update time	Fast Approx. 0.2 second. Slow Approx. 0.6 second.
Over range Indicator	Display show " - - - - " when in over range status.
Data output	RS-232 serial computer interface.
Overload Capacity	Max. 7 kg.
Full Scale Deflection	Approx. 2 mm max.
Zero/tare Control	Max. full capacity.
Circuit	Exclusive microprocessor LSI-circuit.
Power Supply	6 x 1.5 V AA (UM-3) size battery or DC 9V adapter (not included).
Power Consumption	Approx. DC 28 mA

Transducer	Exclusive load cell.
Operating Temperature	0°C to 50°C (32°F to 122°F).
Operating Humidity	Less than 80% RH.
Dimension	215 x 90 x 45 mm (8.5 x 3.5 x 1.8 inch).
Weight	650 g (1.43 LB)/with batteries.
Mounting Holes	Main instrument with mounting holes are provided on the back case, easy stand mounting.
Accessories Included	Operating manual 1 PC. Flat-head adapter..... 1 PC. Hook adapter 1 PC. Cone head adapter 1 PC. Chisel head adapter 1 PC. 120 mm extension rod..... 1 PC. Carrying case 1 PC.
Optional Accessories	* Test stand, Model : FS-1001 * Wedge grip, Model : WG-01 * RS232 cable, Model : UPCB-01. * USB cable, Model : USB-01 * Software for data logging & data recorder. Model : SW-U801-WIN.

3. FRONT PANEL DESCRIPTION

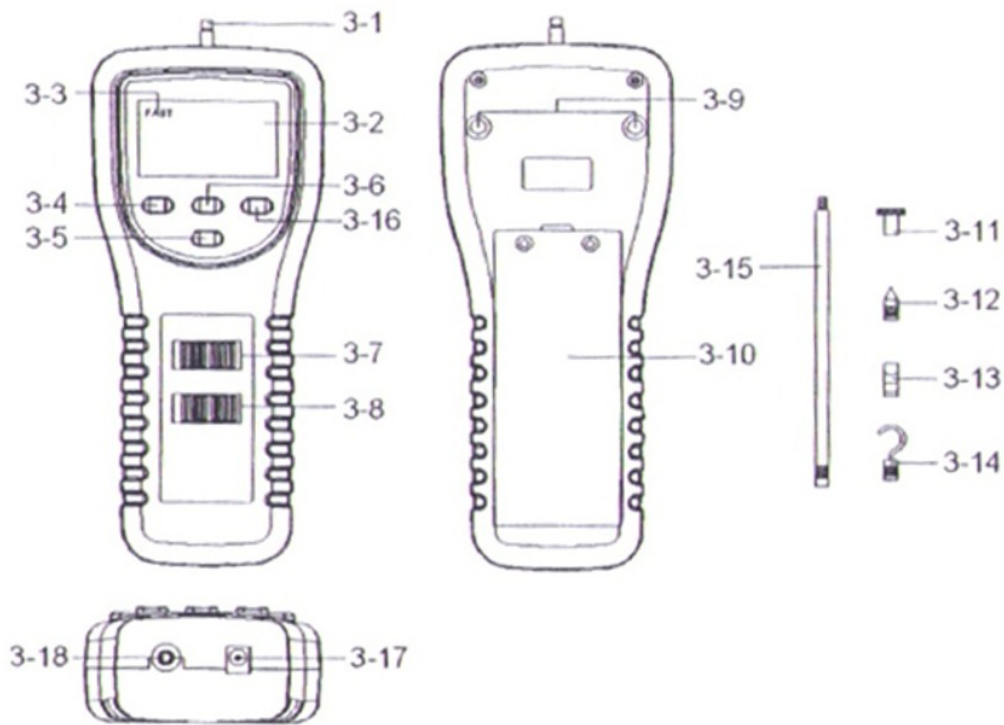

Fig. 1

- | | |
|---|---------------------------------------|
| 3-1 Universal Sensing Head | 3-9 Mounting Holes/fixing Screws |
| 3-2 LCD Display | 3-10 Battery Cover/Compartment |
| 3-3 Fast Indicator | 3-11 Flate-head Adapter |
| 3-4 FAST/SLOW Button | 3-12 Cone Adapter |
| 3-5 LCD Reverse Display Button | 3-13 Chisel Adapter |
| 3-6 Zero Button | 3-14 Hook Adapter |
| 3-7 g/oz/Newton Unit Switch | 3-15 120 mm Extension Rod |
| 3-8 Power Off/On/Peak Hold
0 = Off, 1 = On | 3-16 LCD Back Light Button |
| | 3-17 DC 9V Power Adapter Input Socket |
| | 3-18 RS-232 output terminal |

4. MEASURING PROCEDURE

4-1 The Tension & Compression measuring function is executed automatically.

- 1) Compression measurement, the display will show the " - " mark automatically.

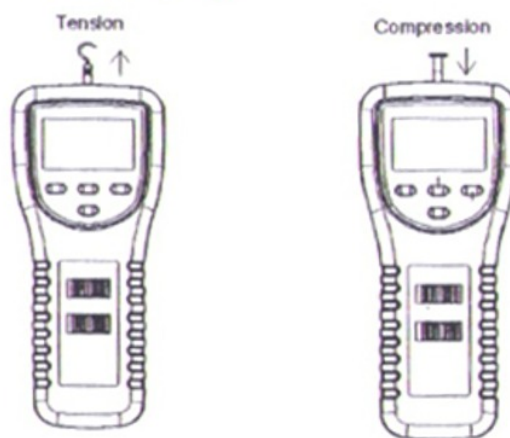

- 2) During the measurement, the SENSING HEAD along the adapter has to be on a line with measuring object. (ref. Fig. 2)

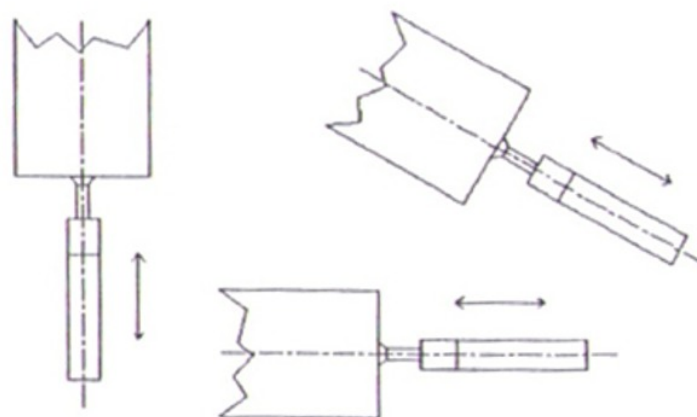

Fig. 2

- 3) Rotate the SENSING HEAD is prohibited. Some certain angles between SENSING HEAD & measuring object are not allowed (ref. Fig. 3).

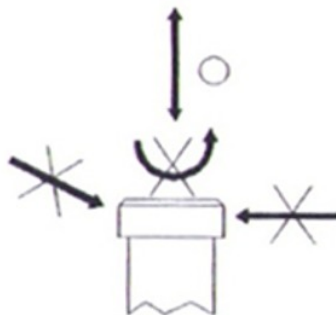

Fig. 3

4-2 Normal Measurement

- 1) Slide the " Power Off/On/Peak Hold Switch " (3-8, Fig. 1) to the " On " position.
0 = Off, 1 = On
- 2) Determine display unit of g, oz or Newton by selecting " g/oz/Newton Unit Switch " (3-7, Fig. 1).
- 3) Connect " Sensing Head " (3-1, Fig. 1) with proper " Adapter " (3-11 to 3-14, Fig. 1) and the " Measuring Object " should be in straight line. Don't give any force in standby mode..
- 4) " Zero Adjust " by pushing " Zero Button " (3-6, Fig. 1) before every measurement.
- 5) Start measurement by giving force (push or pull), then the LCD will display the Average reading value.

Note :

** During the measurement, if intend to change the display direction, just push the " Reverse Button " (3-5, Fig. 1) once.*

- * There are two kind sampling time of display, FAST and SLOW. Push the " FAST/SLOW Button " once (3-4, Fig. 1), if the upper left corner of LCD show " FAST " (Fast Indicator, 3-3, Fig. 1), then the display reading is under the operation of fast sampling time.
- * If the upper left corner of LCD not show the " Fast Indicator " (3-3, Fig. 1), the display reading is under the slow sampling time.
- * Over range display of tension function, LCD will show " ----- "
- * Over range display of compression function, LCD will show " ----- "

4-3 Peak Hold Measurement

The meter can measure the peak value of force both of tension & compression operation. The operation procedures of Peak Hold Measurement are same as above " 4-2 Normal Measurement " but should slide the " Power Off/On/Peak Hold Switch " (3-8, Fig. 1) to the " PEAK H. " position.

Slide the " Power Off/On/Peak Hold Switch " (3-8, Fig. 1) to the " On " position will cancel the peak hold function.

4-4 LCD Back Light On/Off

During the measurement, press and hold (> 2 seconds) the "  Button " (3-16, Fig. 1) until LCD Back Light is ON, then it will be off after a period time. several seconds then off automatically

5. BATTERY REPLACEMENT

- 1) When the LCD shows " Lo ", it is necessary to replace the batteries. However, in-spec. measurement may still be made for several hours after low battery indicator appears before the instrument become inaccurate.
- 2) Take out the battery cover (3-10, Fig. 1) away from the instrument and remove the batteries.
- 3) Install the batteries ((6 x 1.5 V AA, UM-3) correctly into the battery case.

6. RS232 PC SERIAL INTERFACE

The instrument features an RS232 output via 3.5 mm Terminal (3-18, Fig. 1).

The connector output is a 16 digit data stream which can be utilized to the user's specific application.

An RS232 lead with the following connection will be required to link the instrument with the PC serial input.

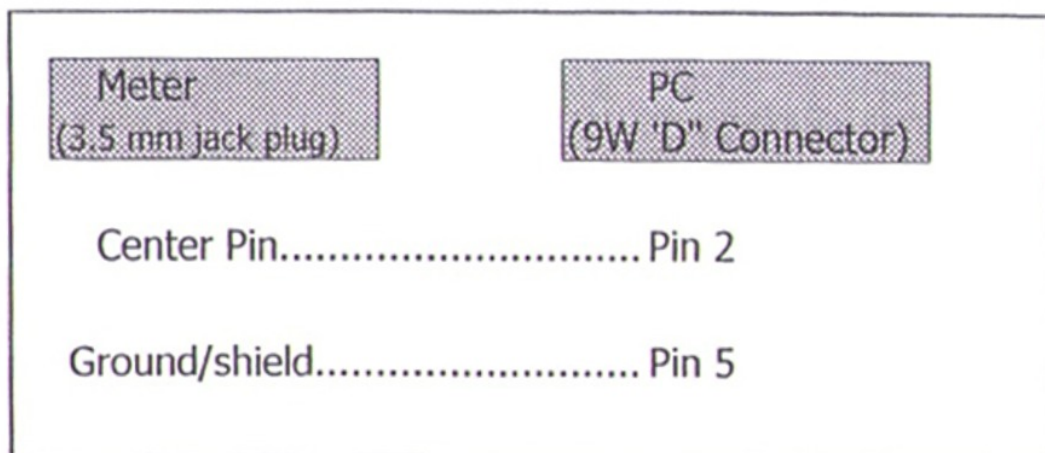

The 16 digit data stream will be displayed in the following format :

D15 D14 D13 D12 D11 D10 D9 D8 D7 D6 D5 D4 D3 D2 D1 D0

Each digit indicate the following status :

D0	End Word
D1 & D8	Display reading, D1 = LSD, D8 = MSD <i>For example :</i> <i>If the display reading is 1234, then D8 to D1 is : 1234</i>
D9	Decimal Point(DP), position from right to the left 0 = No DP, 1 = 1 DP, 2 = 2 DP, 3 = 3 DP
D10	Polarity 0 = Positive 1 = Negative
D11 & D12	Anunuciator for Display
	g = 57 Newton = 59 oz = 58
	Kg = 55 LB = 56
D13	1
D14	4
D15	Start Word

RS232 setting

Baud rate	9600
Parity	No parity
Data bit no.	8 Data bits
Stop bit	1 Stop bit

7. MOUNTING HOLES & OPTIONAL TEST STAND

FORCE GAUGE is a precise instrument, best results are obtained when the gauge is fitted to a test stand. Mounting holes (3-9, Fig. 1) are provided on the back of the gauge for easy stand mounting.

Optional Test Stand & accessory :

* TEST STAND, Model : FS-1001

Test stand, cooperate with Force gauge, whole system will be become the useful tool for material's tension & compression analysis.

Size : 630 x 250 x 230 mm. Weight : 7.02 Kg (15.4 LB).

* WEDGE GRIP, Model : WG-01

Wedge grip, the optional accessory to install to the base of FS-1001 be used to hold the tested material.

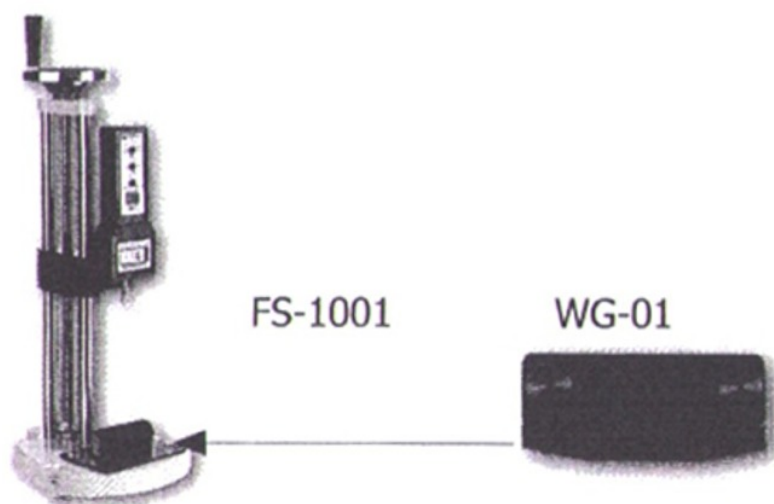

8. APPLICATIONS

8-1 Electronics

- * Test strength of solder points and spot welds on circuit boards.
- * Test wire wraps on clip connection.
- * Test pull strength of modified wire wrap connection on posts.
- * Test spring clip insertion and withdrawal forces.
- * Pull test welds in micro-electronic devices.
- * Measure torque, timing belt tension, sliding friction, etc., on computer peripheral equipment.
- * Test P.C. board insertion force.
- * Test insertion and withdrawal forces of various circuit components such as transistors and integrated circuits.
- * Test actuating force of snap action switches.

8-2 Business Equipment

- * Measure force required to perforate cards.
- * Measure load on slitter knives.
- * Measure actuating requirements of typewriter.
- * Test clutch release force.
- * Measure torque, timing belt tension (by deflection), sliding friction, etc., on computer peripheral equipment.
- * Test adhesion strength of labels and stickers.
- * Test load on paper thickness gages.
- * Measure tension of pencils.
- * Test actuating requirements on push buttons and flip switches.

8-3 Chemical & Plastics

- * Test film bond strengths.
- * Tensile test rubber, fibers and filaments.
- * Measure firmness of polyurethane foam.
- * Test crush strength of pills (medicine)
- * Test peel strength of adhesives.
- * measure compression of ceramic compounds.
- * Test vacuum take-down pressure on process machines.

8-4 Machinery & Manufacturing

- * Test load on wire feel
- * Test force to open cabinet doors.
- * Test sprocket chain tension.
- * Test pull-out forced of drive shaft.
- * Rate testing of springs in systems.
- * Calibrate a cantilever beam-type Apparatus to obtain a force/deflection relationship.

8-5 Automotive

- * Measure force of seat belt retractors.
- * Measure arm pressure of windshield wipers.
- * Measure flip force in mechanical snap action switches.
- * Test effort to operate hand tool.
- * Test forces required to move linkages and tension cables.
- * Measure force of odometer pull.
- * Test peel strength of vinyl insert bonded to body side moldings
- * Evaluate physical efforts (door, lock, hood, glove compartment, brake pedal, etc.).

8-6 Other Industries

- * Measure pedal depression force in aircraft.
- * Test hardness of gypsum wallboard.
- * Test keyboard and pedal contact force of organs and pianos.
- * Test force to remove cover tops of aerosol cans.
- * Measure trigger pulling forces on firearms, hand tools etc.
- * Test firmness of sausages in casings.
- * Test integrity of seals on blister packages and plastic bags.
- * Test pressure of surgical instruments (forceps, scissors).
- * Test fruit removal force and fruit firmness.
- * Measure force on spindles of photographic equipment



In this direction will find a vision of the measurement technique:
<http://www.industrial-needs.com/measuring-instruments.htm>

NOTE: "This instrument doesn't have ATEX protection, so it should not be used in potentially explosive atmospheres (powder, flammable gases)."