



Tursdale Technical Services Ltd  
Unit N12B  
Tursdale Business Park  
Co. Durham  
DH6 5PG  
United Kingdom  
Phone: +44 (0) 191 377 3398  
Fax: +44 (0) 191 377 3357  
[info@tursdaletechnicalservices.co.uk](mailto:info@tursdaletechnicalservices.co.uk)  
<http://www.industrial-needs.com/>

## MANUAL PCE-HT200



## Contents

Chapter 1. Introduction .....	3
1.1 Main features and application .....	3
1.2 Fundamental.....	3
Chapter 2. Technical Specification: .....	3
Chapter 3. Main functions and configuration .....	3
3.1 Main functions .....	3
3.2 Basic configurations.....	3
3.3 Optional configurations: .....	4
Chapter 4. Composition .....	4
4.1 Composition of main unit See figure 2.....	4
4.2 Usage of battery house.....	4
4.3 Usage of display screen .....	4
4.4 Usage of press button.....	5
4.5 Usage of communication interface .....	5
Chapter 5. Functions setting.....	5
5.1 Start.....	5
5.2 Max value function .....	6
5.3 Test times function and average value function setting.....	6
5.4 Auto turn off function .....	7
Chapter 6. Measuring .....	7
6.1 Preparation before measuring .....	7
6.2 Calibration.....	7
6.3 Operation method.....	8
6.4 Communication with computer.....	8
Chapter 7. Attention items .....	9
Chapter 8. Maintenance .....	9
Points for consumers attention .....	9

## Chapter 1. Introduction

### 1.1 Main features and application

TIME TH210 Shore A hardness tester (hereafter called hardness tester) is a kind of advanced integral digital hardness tester. It includes measuring device and data processing system. It is of the merit of advanced technology, pocket size, accurate measuring data, appearance beautiful, light weight, and easy to operate. It can be connected with computer by RS-232 communication cable. It is mainly used to measure hardness of hard plastic and rubber such as heat plasticity, hard resin, floor materials, bowling etc. Especially suitable for finished products in working situation.

### 1.2 Fundamental

When the steel indenter of certain shape is pushed into the sample surface vertically with testing force, and when surfaces of pressure foot and the sample touched completely (see figure 1), the indenter extends out for a certain length "L" from the pressure foot plane. Greater length "L" means lower Shore hardness value and smaller length "L" means bigger Shore hardness value. The formula is  $HA=100-L/0.025$ , HA is Shore A hardness value in the formula.

The formula indicates that the hardness value is relevant to displacement of indenter. Displacement of the indenter is measured by the sensor, then the value is given through calculation and processing of the CPU.

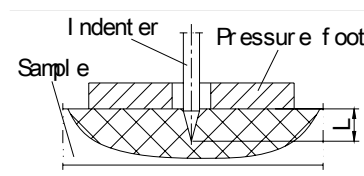

(Figure 1)

## Chapter 2. Technical Specification:

Measuring range:	0HA 100HA
Measuring error within	20HA 90HA, error $\leq \pm 1$ HA
Resolution:	0.2HA
Environmental temperature	0 °C 40 °C
Power supply	1.55V×3 button batteries and 5V AC- DC adapter
Dimensions:	168mm×31mm×30mm
Weight:	144g

## Chapter 3. Main functions and configuration

### 3.1 Main functions

Peak value locked storage, average value calculating and low-voltage alarming.  
Data communication with computer by use of RS-232 communication cable of company  
Shut off automatically.

### 3.2 Basic configurations

TH200 main unit Three SR44 button batteries

### 3.3 Optional configurations:

RS-232 communication cable

Shore hardness stand of TH200FJ

## Chapter 4. Composition

### 4.1 Composition of main unit See figure 2

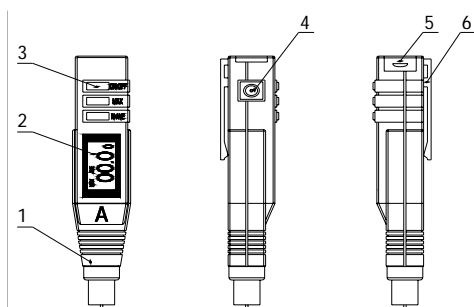

(Figure 2)

- |                  |                            |
|------------------|----------------------------|
| 1. TH200unit     | 2. Display screen          |
| 3. Press button  | 4. Communication interface |
| 5. Battery house | 6. Hook                    |

### 4.2 Usage of battery house

Pull out and turn the battery house slightly to make it rotate about 90° around axis with thumb, see figure 3. Put into three button batteries. Take care of positive pole symbol “+” consistently. At last, turn battery house reversely until clamped closely with main unit, see figure 3.

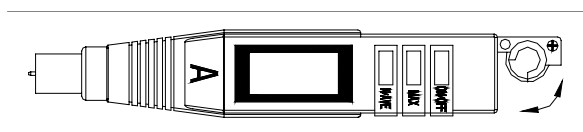

(Figure 3)

### 4.3 Usage of display screen

Screen is used to display results as well as working states of tester. The screen is divided into 5 displaying areas which is stated as follow, see figure 4

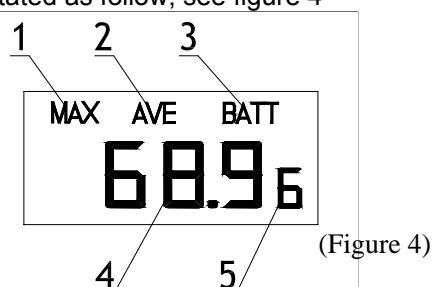

(Figure 4)

- 1---MAX Max value function (tester locked automatically and stored peak value),  
 2---AVE Average value function,

- 3---BATT Low-voltage indication,
- 4---Hardness value
- 5---Test times,

#### 4.4 Usage of press button

Buttons is used to turn on or turn off power as well as set functions, see figure 5:

- N/AVE---- Test times function and Average function button,
- MAX-----Max value function button
- ON/OFF---Switch button red.

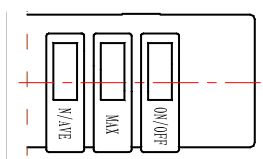

(Figure 5)

#### 4.5 Usage of communication interface

It can communicate with computer by RS-232 communication cable. See figure 6.

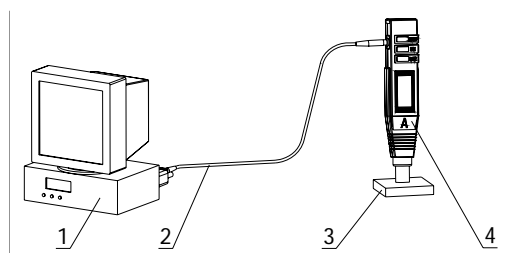

(Figure 6)

- 1. Computer
- 2. Communication cable
- 3. sample
- 4. Hardness tester

## Chapter 5. Functions setting

### 5.1 Start

Press button ON/Off-screen displays “0” firstly after seconds, the data displayed changed as “00.0”. At same time, the program of hardness tester starts to work, see figure 7.

Press switch button ON/OFF again,

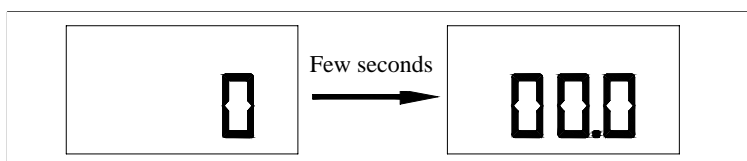

(Figure 7)

## 5.2 Max value function

Press MAX button, screen displays MAX symbol, see figure 8. The value is the maximum of once test (auto locks peak value function). If you want to cancel this function, only need to press MAX again (MAX symbol vanishes).

Under MAX situation (when do not set Ave. function), it needs to press button MAX to clear zero before next measurement (MAX symbol vanishes correspondingly), then press MAX again to start measuring.

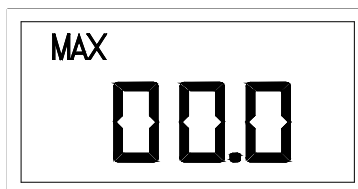

(Figure 8)

## 5.3 Test times function and average value function setting

Press down button N/AVE (the MAX function do not be set), the "00.0" vanishes and displays AVE symbol at same time as well as display test times on right bottom corner (before setting, it displays the test times to be set last time, the test times is supposed as 7 on illustration), see figure 9. At this moment, the test times setting should be carried on. The setting method sees below 5.3.1. Supposed setting value is 3 shown on screen, see figure 10 seconds later of completed setting, displaying area restore hardness value as "00.0" and test times changed as "0" at same time, see figure 11 It indicates setting successful and can be put into measuring situation. If want to cancel this function, only need to press button N/AVE again, AVE symbol and test times vanishes at this moment.

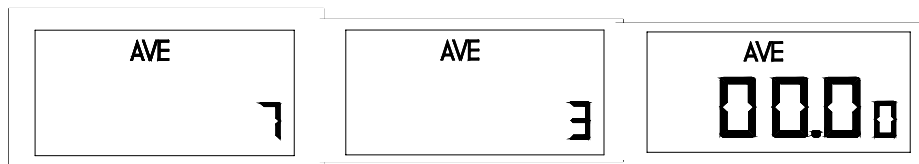

(Figure 9)

(Figure 10)

(Figure 11)

### 5.3.1 Setting methods of test times

Under figure 9 state, the test times can be set by press button N/AVE continually. The max test times are 9, in which the times can be circled within 0-9 range. There are two kinds of setting method:

**Method 1** Press button N/AVE for a while, the times circulated among 0-9 range until it reaches requirement, then release button at once and completed.

**Method 2** Press button N/AVE repeatedly. The value adds one for every times press in which the times circulated among 0-9 range until reaches requirement, then release button at once and completed. After completed test times setting, machine is in ready state for testing, see figure 11.

### GAS Arrester Testing.

Today, most equipments and electrical installations are protected by MOVs and GAS arresters. The Multifunction Tester can test these devices to establish if the devices are still operating correctly or not. Energy conservation is featured on all these new Advanced Products.

EnerSave™ limits the test duration to about 10 Seconds to save energy.

This new generation of test equipments has no moving parts. All calibration are saved internally in a non volatile memory.

Calibration can be done at any calibration facility around the world, without the need for dedicated calibration equipment.

This makes these products easier to maintain and lower the cost of calibration and ownership.

Their calibration interval can be extended without much problem.  
 They comply to all the latest regulations, including UK 16<sup>Th</sup> Edition.  
 This product family is part of our new World Class series.  
 They prominently feature heavy duty protections in their circuitry.

### 5.3.2 Average value setting:

After test times being set, hardness tester can judge based on test times. When test times are among 3-9, hardness tester displays current measured value and test times of this test. When reached the set times, automatically cancels rough error and displays average value. If rough error is too larger, displays "E.", see figure 12. When test times is set as 2, arithmetical mean of the two tested data will be displayed. When test times is set as 1, tester displays the measure value only. After average value displays for 8 seconds, hardness tester clears zero automatically and restores ready state. The times to be set are still valid.

User can record measured data by manual and calculates arithmetic mean. The average value is divided as max average value and random average value. When calculating max average value, the max function and average function should be set and displays MAX and AVE symbol at same time; see figure 13. Their setting method is the same as above mentioned and setting order is not required. When calculating random average value, only need to set average function and displays AVE on screen, see figure 11. The setting method is the same as above mentioned

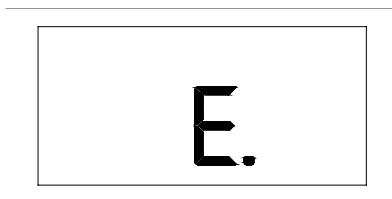

(Figure 12)

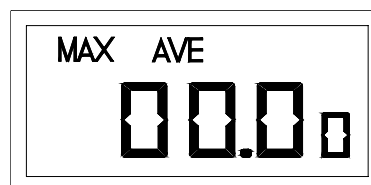

(Figure 13)

## 5.4 Auto turn off function

If tester is in ready state for three minutes, and flashes on

Screen for fifteen seconds then turns off automatically.

## Chapter 6. Measuring

### 6.1 Preparation before measuring

The preparation of sample: The sample thickness should be equable, surface smooth, no bubble inner, no damaged, no impurities and so on.

Tester preparation: disassemble protective sleeve and put into batteries or connect power adapter.

### 6.2 Calibration

6.2.1 Zero point calibration: After switch on power, hardness tester is in ready state. The protrusion length of indenter needle is max; the hardness value displayed on the screen is zero.

#### 6.2.2 Non zero point calibration

Make bottom surface of pressure foot of hardness tester touch glass surface completely. At this moment, hardness value displayed should be 100 on the screen, see figure 14. Note: when calibrating in this method, in order to protect indenter, it should avoid indenter point to touch glass promptly and rudely. Otherwise, it is easy to damage the point of indenter needle of hardness tester and operate abnormally.

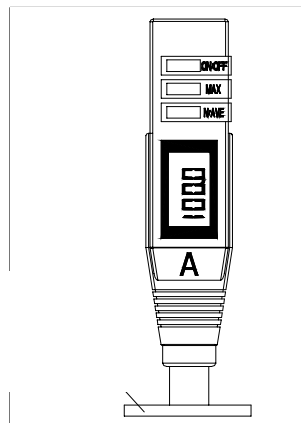

## 6.3 Operation method

### 6.3.1 Manual measure:

Place the sample on the slab. Hold the tester and press indenter needle into sample vertically and slowly to avoid any shake. When the bottom of pressure foot touches the sample surface completely, read the value within 1 second. The displayed value then is the hardness value of the sample.



(Figure 15)

### 6.3.2 Measuring by the operating stand:

A After completed connection of hardness tester with stand, place sample on work table (see shore hardness tester stand of TH200FJ)

B Assemble the balancing weight with balancing fixing rod together through its middle hole. Then press down handle, at this moment, work table and sample move up together, see (figure 16). When pressure foot of the hardness tester touches sample surface and balancing weight slightly moves up, the testing state is reached. Read the display data on screen of hardness tester in 1 second. This value is Shore A hardness value.

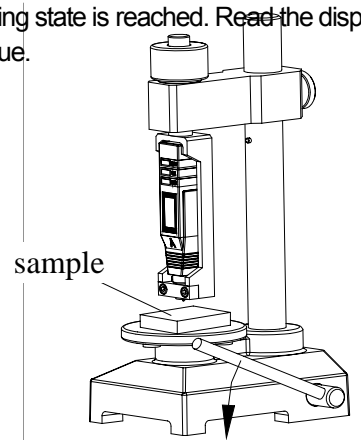

(Figure 16)

## 6.4 Communication with computer

This tester can communicate with computer which the band rate is 9600. The data is transferred by text file which can receive by common communication software (such as super technical device of WINDOWS). The RS-232 communication cable is needed to connect the tester with a computer, see figure 6. It can send signal to computer when gets the reading value. The operation procedure is as follow when using super terminal device of WINDOWS:



6.4.1 Connect the nine cores bottom of RS-232 communication cable to series interface of computer. Insert the other bottom into communication interface of hardness tester (series interface), see figure 6. Switch on the tester.

6.4.2 Click “start” → “program” → “Accessories” → “communication” on WINDOWS to HyperTerminal.

6.4.3 Run HyperTerminal, type in a file name at new established connection, then press “Enter”.

6.4.4 Select the series interface of communication cable, then select band rate 9600, press “Enter”. At this moment, the measured value should be displayed on computer.

6.4.5 If you want to store the measured result, select “Disconnect” under “dial” menu of HyperTerminal, select “save as” under “file” menu. Type in a file’s name. That is OK.

## Chapter 7. Attention items

7.1. The indenter of hardness tester is sharp cone, forbid to touch it with glass plate forcibly in order to protect it. Otherwise, it is easy to be damaged and to operate abnormally.

7.2. Forbid hardness tester collision and fall break. After service, pull on protective sleeve so as to protect the indenter needle.

7.3. When displays symbol BATT in low-voltage, see figure 8, replace batteries in time and pay attention to the pole of batteries, see figure 5.

7.4 After completed measurement by using operating stand, see figure 7, close the joint cover of hardness tester so as to avoid dust entering into.

## Chapter 8. Maintenance

### 8.1. Routine maintenance

This hardness tester should avoid impact and heavy loading, and keep away from strong magnetic field, damp or oil environment.

If store for long time and do not use it, take out batteries and take care of them.

When do not using the tester, please put it into packing box.

8.2. Maintenance. If any abnormal phenomenon occurs, please contact the service maintenance centre of company.

8.3. The list of non maintenance parts

Items	Name	Quantity	Remarks
1	Indenter needle	1	
2	Button battery	3	

## Points for consumers attention

1. From purchased date, the products occur any fault except for non guarantee maintenance parts, will free maintain by warranty card and invoice copy within one year. If you could not show above mentioned requirement, company calculates guarantee period in accordance with the date of leaving factory, valid period is one year.

2. If the fault product exceeds maintenance period, in accordance with stipulation of Company, it will be taken charge of maintenance and service.

3. The “special configuration” out of Company’s approved products would take fees in accordance with related standards.

4. The product should not receive free maintenance service if belongs to conditions as follow: storage unsuitable, operated incorrectly which is not in accordance with manual book, disassembled, altered by oneself as well as no purchasing proof.

In this direction will find a vision of the measurement technique:

<http://www.industrial-needs.com/measuring-instruments.htm>

**NOTE:** "This instrument doesn't have ATEX protection, so it should not be used in potentially explosive atmospheres (powder, flammable gases)."