



Tursdale Technical Services Ltd  
Unit N12B  
Tursdale Business Park  
Co. Durham  
DH6 5PG  
United Kingdom  
Phone: +44 ( 0 ) 191 377 3398  
Fax: +44 ( 0 ) 191 377 3357  
[info@tursdaletechnicalservices.co.uk](mailto:info@tursdaletechnicalservices.co.uk)  
<http://www.industrial-needs.com/>

## Three-phase power analyzer Manual PCE-PA 8000



# Operation Manual

## Caution Symbol

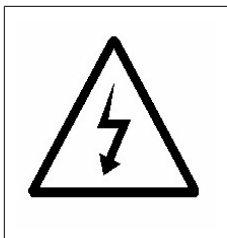

**Caution :**

- \* **Risk of electric shock !**
- \* **During the measurement, do not open the cabinet.**



**Caution :**

- \* **Do not apply the overload voltage, current to the input terminal !**
- \* **Remove test leads before open the battery cover !**
- \* **Cleaning - Only use the dry cloth to clean the plastic case !**

## Environment Conditions

- \* Installation Categories III 600V.
- \* Pollution Degree 2.
- \* Altitude up to 2000 meters.
- \* Indoor use.
- \* Relative humidity 80% max.

# TABLE OF CONTENTS

1. FEATURES.....	1
2. SPECIFICATIONS.....	2
2-1 General Specifications.....	2
2-2 Electrical Specifications.....	4
3. FRONT PANEL DESCRIPTION.....	8
4. MEASURING PREPARATION .....	10
4-1 The original screen.....	10
4-2 Entry the measurement Screen.....	10
4-3 The summary description of keyboard.....	12
4-4 SETUP KEY description.....	13
4-5 Setting function description before measuring.....	14
5. MEASURING PROCEDURES .....	35
5-1 1 $\Phi$ 2W ( one phase by two wires ) measurement.....	35
5-2 1 $\Phi$ 3W ( one phase by three wires ) measurement.....	36
5-3 3 $\Phi$ 3W ( three phase by three wires ) measurement.....	38
5-4 3 $\Phi$ 4W ( three phase by four wires ) measurement.....	39
5-5 The CT and PT measurement.....	41
5-6 ZERO adjustment for Watt Hour.....	42
5-7 Data Logger function.....	43
5-8 Data Hold function.....	45
5-9 Backlight key.....	46
5-10 A ( Current ) Range key.....	46
5-11 LOWBAT screen.....	48
5-12 Appendix 1.....	49
6. MAINTENANCE.....	50
6-1 Cleaning.....	50
6-2 Replacement of batteries .....	50
7. RS232 PC SERIAL INTERFACE.....	51
8. Download the saving data from the SD card to the computer ( EXCEL software ) .....	53
9. PATENT.....	57
10. THE ADDRESS OF AFTER SERVICE CENTER .....	58

# 1. Features

- \* Analysis for 3 phase multi-power system, 1P/2W, 1P/3W, 3P/3W, 3P/4W
- \* Voltage & Current are the True RMS value.
- \* True Power ( KW · MW · GW ) measurement.
- \* Apparent Power ( KVA · MVA · GVA ) measurement.
- \* Reactive Power ( KVAR MVAR · GVAR) measurement.
- \* Watt-Hour ( WH · SH · QH · PFH ).
- \* Power Factor( PF ) · Phase Angle(  $\Phi$  ).
- \* Voltage measurement range : 10 to 600 ACV
- \* Current measurement range: 0.2A to 1200 ACA.
- \* Programmable CT ratio (1 to 600) and PT ratio (1 to 1000).
- \* ACV input impedance is 10 Mega ohms.
- \* Safety Standard : IEC 1010, CAT III 600V
- \* Built-in clock and Calendar, real time data record with SD memory card , sampling time set from 2 to 7200 seconds. Just slot in the SD card into the computer, it can down load the all the measured value with the time information ( year/month/data/ hour/minute/second ) to the Excel directly, then user can make the further data analysis by themselves.
- \* Complete set with 4 PCs Test Leads, 4 PCs Alligator clips, 3 PCs Clamp Probe, AC to DC 9V adapter, 2 G SD memory card and Carrying bag.
- \* Computer data output, can cooperate with USB Cable /USB-01 RS232 cable/UPCB-02 and Data Acquisition software, SW-U801-WIN.

## 2. Specifications

### **2-1 General Specifications:**

Circuit	Custom one-chip of microprocessor LSI circuit	
Display	<ul style="list-style-type: none"> <li>* LCD Size : 81.4 X 61 mm ( 3.2 X 2.4 inch )</li> <li>* Dot Matrix LCD (320 X 240 pixels ) with back light.</li> </ul>	
Measurement	<ul style="list-style-type: none"> <li>* ACV</li> <li>* ACA</li> <li>* AC WATT ( True Power )</li> <li>AC WATT( Apparent Power )</li> <li>AC WATT( Reactive Power )</li> <li>* Power factor</li> <li>* Phase angle</li> <li>* Frequency</li> </ul>	
Wire connections	1P/2W, 1P/3W, 3P/3W, 3P/4W.	
Voltage ranges	10 ACV to 600 ACV, auto range.	
Current ranges	0.2 ACA to 1200 ACA, auto range/manual range.	
Safety standard	IEC1010 CAT III 600 V.	
ACV input impedance	10 Mega ohms.	
Range select	ACV	Auto range.
	ACA	Auto range & manual range.
Clamp frequency response	40 Hz to 1 KHz.	
Spec. tested frequency	45 to 65 Hz.	
Over load protection	ACV	720 ACV rms
	ACA	1300 ACA with clamp probe CP-1200

Over Indicator	Show " OL ".
Under Indicator	Show " UR ".
Data Hold	Freeze the display reading.
Data Record	SD Card Record.
Sampling Time	Approx. 1 second.
Power ON/OFF	Manual OFF by push button.
Real time data logger	* Real time data logger, saved the data into SD memory card and down load the all the measured value with the time information ( year/month/data/ hour/minute/second ) down load to the Excel
	* Integration time for data logger : 2 seconds to 7200 seconds, the during of setting step are 2 seconds.
Data Output USB/RS232 * <i>Computer interface</i>	RS232 computer serial interface : * Connect the optional USB cable USB-01 will get the USB plug. * Connect the optional RS232 cable UPCB-02 will get the RS232 plug.
Operating Temperature	0 to 50°C ( 32 to 122°F ).
Operating Humidity	Less than 80% R.H..
Power Supply	* DC 1.5V, AA ( UM-3 ) Battery X 8 PCs (Alkaline or heavy-duty battery). * AC to DC 9V power adapter.
Power Consumption	* Meter : 300 DCmA. * Clamp : 34 DCmA.
Clamp max. conductor Size	50 mm ( 2.0 inch ) Dia.

Weight	<ul style="list-style-type: none"> <li>* Meter : 948g ( includes batteries )</li> <li>* Clamp ( included cable ) : 467g</li> </ul>
Dimension	<i>Meter :</i> 225 X 125 X 64 mm ( 8.86 X 4.92 X 2.52 inch )
	<i>Clamp :</i> 210 X 64 X 33mm ( 8.3 X 2.5 X 1.3 inch )
	Clamp Jaw : 86 mm (3.4 inch)- outside
Accessories Included	<ul style="list-style-type: none"> <li>* Instruction manual..... 1 PC</li> <li>* Test Leads (TL88-4AT)..... 1 Set (4 PCs)</li> <li>* Alligator clips (TL88-4AC) 1 Set (4 PCs)</li> <li>* Clamp Probe ( CP-1200 )..... 3 PCs</li> <li>* AC to DC 9V adapter..... 1 PC</li> <li>* SD card ( 2 G )..... 1 PC</li> <li>* Carrying bag.....1 PC</li> </ul>
Optional Accessories	<ul style="list-style-type: none"> <li>* USB Cable , USB-01</li> <li>* RS232 cable, UPCB-02</li> <li>* Data Acquisition software, SW-U811-WIN</li> </ul>

## ***2-2 Electrical Specifications:***

### **ACV**

<b>Range</b>	<b>Resolution</b>	<b>Accuracy</b>
10.0V to 600.0V * Phase to neutral line	0.1V	± (0.5%+0.5V)
10.0V to 600.0V * Phase to phase		

### **ACA**

<b>Range</b>	<b>Resolution</b>	<b>Accuracy</b>
20A	0.001A, < 10 A 0.01A, ≥ 10 A	± (0.5%+0.1A)
200A	0.01A, < 100 A 0.1A, ≥ 100 A	± (0.5%+0.5A)
1200A	0.1A, < 1000 A 1A, ≥ 1000 A	± (0.5%+5A)

### **Power factor**

<b>Range</b>	<b>Resolution</b>	<b>Accuracy</b>
0.00 to 1.00	0.01	± 0.04

#### **Remark :**

\* **PFH** : Long term power factor

\* **PFΣ** :

*For 3Φ 4W, 3Φ 3W*

$$PF_{\Sigma} = ( PF1 + PF2 + PF3 )/3$$

*For 1Φ 3W*

$$PF_{\Sigma} = ( PF1 + PF2 )/2$$

### **Φ ( Phase angle )**

<b>Range</b>	<b>Resolution</b>	<b>Accuracy</b>
-180° to 180°	0.1°	± 1° * ACOS ( PF )

### **Frequency**

<b>Range</b>	<b>Resolution</b>	<b>Accuracy</b>
45 to 65 Hz	0.1 Hz	0.1 Hz



### **Active (Real) Power**

<b>Range</b>	<b>Resolution</b>	<b>Accuracy</b>
0.000 to 9.999 KW	*0.001/0.01/0.1 KW	± (1%+0.008KW)
10.00 to 99.99 KW	*0.01/0.1 KW	± (1%+0.08KW)
100.0 to 999.9 KW	0.1 KW	± (1%+0.8KW)
1.000 to 9.999 MW	0.001 MW	± (1%+0.008MW)

\* : The resolution is changed according the different ACA range.

### **Apparent Power**

<b>Range</b>	<b>Resolution</b>	<b>Accuracy</b>
0.000 to 9.999 KVA	*0.001/0.01/0.1KVA	± (1%+0.008KVA)
10.00 to 99.99 KVA	*0.01/0.1 KVA	± (1%+0.08KVA)
100.0 to 999.9 KVA	0.1 KVA	± (1%+0.8KVA)
1.000 to 9.999 MVA	0.001 MVA	± (1%+0.008MVA)

\* : The resolution is changed according the different ACA range.

### **Reactive Power**

<b>Range</b>	<b>Resolution</b>	<b>Accuracy</b>
0.000 to 9.999 KVAR	*0.001/0.01/0.1KVAR	± (1%+0.008 KVAR)
10.00 to 99.99 KVAR	*0.01/0.1 KVAR	± (1%+0.08 KVAR)
100.0 to 999.9 KVAR	0.1 KVAR	± (1%+0.8 KVAR)
1.000 to 9.999 MVAR	0.001 MVAR	± (1%+0.008 MVAR)

\* : The resolution is changed according the different ACA range.

**Watt Hour ( Active Power Hour ) : WH**

<b>Range</b>	<b>Resolution</b>	<b>Accuracy</b>
0.000 to 9.999 KWH	0.001 KWH	± (2%+0.008 KWH)
10.00 to 99.99 KWH	0.01 KWH	± (2%+0.08 KWH)
100.0 to 999.9 KWH	0.1 KWH	± (2%+0.8 KWH)
1.000 to 9.999 MWH	0.001 MWH	± (2%+0.008 MWH)

**VA Hour ( Apparent Power Hour ) : SH**

<b>Range</b>	<b>Resolution</b>	<b>Accuracy</b>
0.000 to 9.999 KVAH	0.001 KVAH	± (2%+0.008 KVAH)
10.00 to 99.99 KVAH	0.01 KVAH	± (2%+0.08 KVAH)
100.0 to 999.9 KVAH	0.1 KVAH	± (2%+0.8 KVAH)
1.000 to 9.999 MVAH	0.001 MVAH	± (2%+0.008 MVAH)

**VAR Hour ( Reactive Power Hour ) : QH**

<b>Range</b>	<b>Resolution</b>	<b>Accuracy</b>
0.000 to 9.999 KVARH	0.001 KVARH	± (2%+0.008 KVARH)
10.00 to 99.99 KVARH	0.01 KVARH	± (2%+0.08 KVARH)
100.0 to 999.9 KVARH	0.1 KVARH	± (2%+0.8 KVARH)
1.000 to 9.999 MVARH	0.001 MVARH	± (2%+0.008 MVARH)

# 3. Front Panel Description

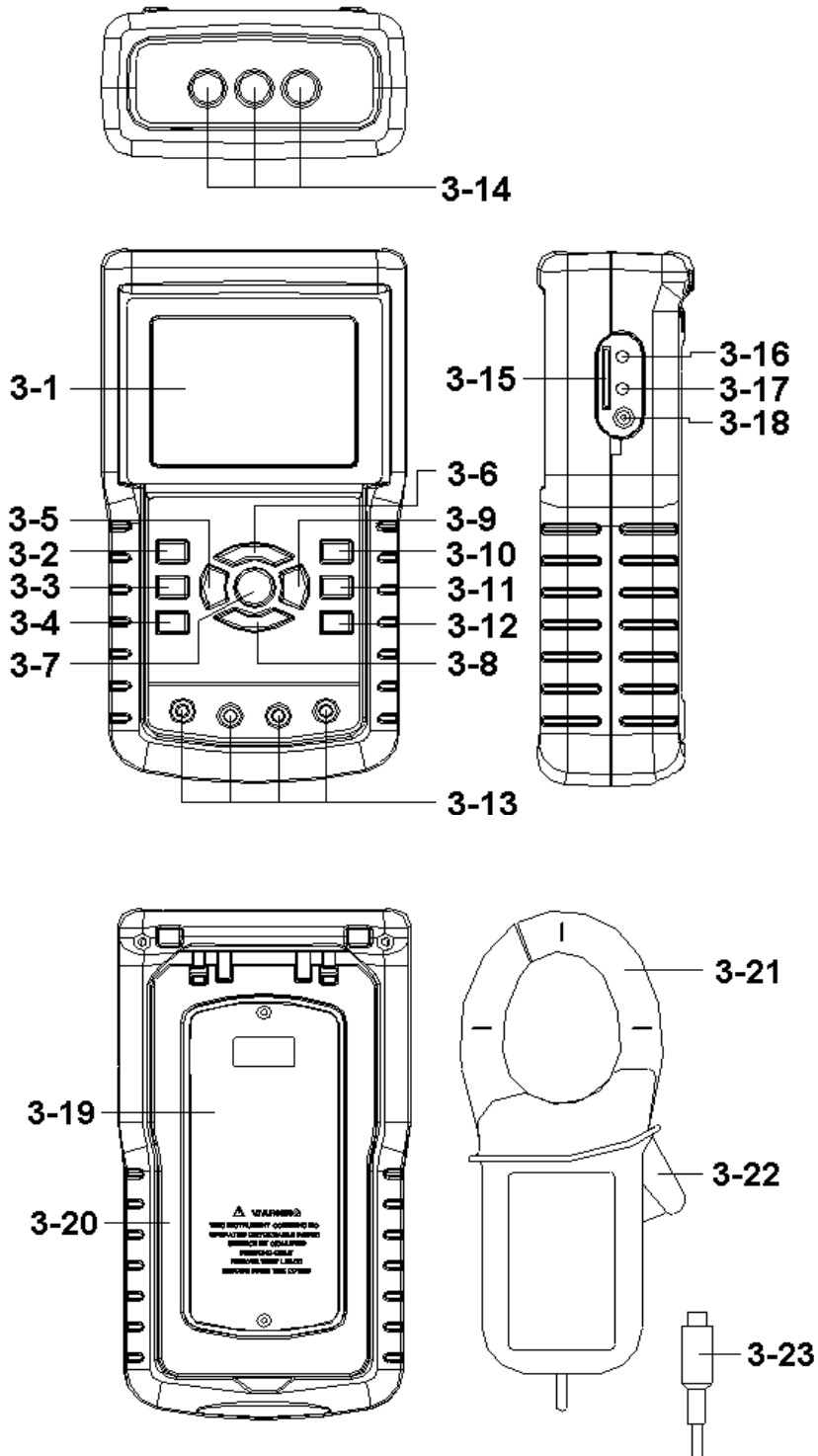

- 3-1 Display
- 3-2 1 $\Phi$  3 $\Phi$  ( Phase/wire ) key button
- 3-3 ▲ key button
- 3-4 ▼ key button
- 3-5 Hold key button
- 3-6 Backlight key button
- 3-7 Power key button
- 3-8 Exit key button
- 3-9 REC key button
- 3-10 A ( current ) range key button
- 3-11 Shift key button
- 3-12 Setup key button
- 3-13 Voltage input terminals
- 3-14 Current probe input sockets
- 3-15 SD card socket
- 3-16 RS232 socket
- 3-17 Reset button
- 3-18 DC 9V power adapter socket
- 3-19 Battery Cover/Battery compartment
- 3-20 Stand
- 3-21 Current Sense Jaw
- 3-22 Trigger
- 3-23 Plug of current probe

## 4. Measuring Preparation

### ***4-1 The original screen***

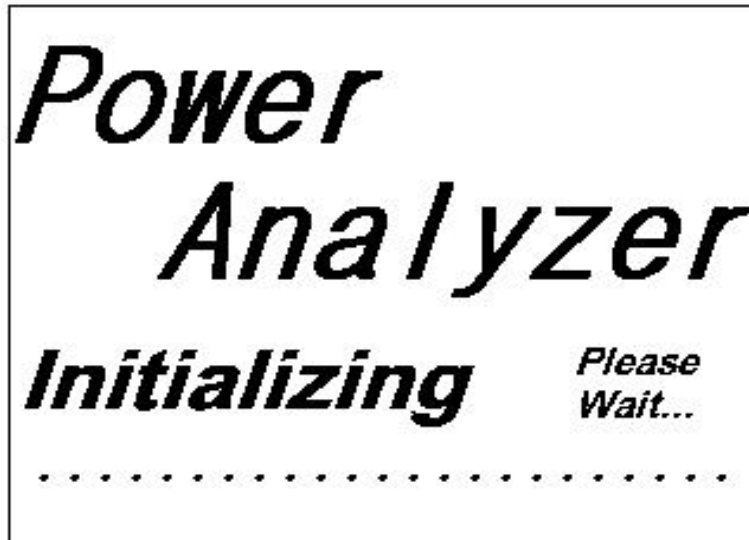

### ***4-2 Entry the measurement Screen***

- 1) The bottom right display of screen 1 will show as " SD Check " along with blinking while inserting SD CARD then disappears after several seconds that indicates the data from SD CARD has been read completed.
- 2) The bottom right display of screen 2 will show as " NO DISK " along with blinking when SD CARD is not inserted.

screen 1 ( 4-2 )

<b>V12:</b>	0.0 V	<b>V1:</b>	0.0 V	<b>A1:</b>	0.00 A
<b>V23:</b>	0.0 V	<b>V2:</b>	0.0 V	<b>A2:</b>	0.00 A
<b>V31:</b>	0.0 V	<b>V3:</b>	0.0 V	<b>A3:</b>	0.00 A
<b>P1:</b>	-0.000 KW	<b>S1:</b>	0.000KVA	<b>Q1:</b>	-0.000 KVAR
<b>P2:</b>	-0.000 KW	<b>S2:</b>	0.000KVA	<b>Q2:</b>	-0.000 KVAR
<b>P3:</b>	-0.000 KW	<b>S3:</b>	0.000KVA	<b>Q3:</b>	-0.000 KVAR
<b>PΣ :</b>	-0.000 KW	<b>SΣ :</b>	0.000KVA	<b>QΣ :</b>	-0.000 KVAR
<b>PF1:</b>	-0.00	<b>PF 2:</b>	-0.00	<b>PF 3:</b>	-0.00
<b>PFΣ :</b>	0.00	<b>PF H:</b>	0.00		
<b>Φ 1:</b>	- 0.0°	<b>Φ 2:</b>	- 0.0°	<b>Φ 3:</b>	- 0.0°
<b>WH:</b>	0.000 KWH	<b>SH:</b>	0.000KVAH		
<b>QH:</b>	0.000 KVARH	<b>FREQ:</b>	0.0 Hz		
<b>AUTO</b>	<b>3Φ4W</b>	<b>SEC: 2</b>	<b>CT: 1</b>	<b>PT: 1</b>	<b>SD</b>
<b>20A</b>					<b>Check</b>

screen 1 ( 4-2 )

<b>V12:</b>	0.0 V	<b>V1:</b>	0.0 V	<b>A1:</b>	0.00 A
<b>V23:</b>	0.0 V	<b>V2:</b>	0.0 V	<b>A2:</b>	0.00 A
<b>V31:</b>	0.0 V	<b>V3:</b>	0.0 V	<b>A3:</b>	0.00 A
<b>P1:</b>	-0.000 KW	<b>S1:</b>	0.000KVA	<b>Q1:</b>	-0.000 KVAR
<b>P2:</b>	-0.000 KW	<b>S2:</b>	0.000KVA	<b>Q2:</b>	-0.000 KVAR
<b>P3:</b>	-0.000 KW	<b>S3:</b>	0.000KVA	<b>Q3:</b>	-0.000 KVAR
<b>PΣ :</b>	-0.000 KW	<b>SΣ :</b>	0.000KVA	<b>QΣ :</b>	-0.000 KVAR
<b>PF1:</b>	-0.00	<b>PF 2:</b>	-0.00	<b>PF 3:</b>	-0.00
<b>PFΣ :</b>	0.00	<b>PF H:</b>	0.00		
<b>Φ 1:</b>	- 0.0°	<b>Φ 2:</b>	- 0.0°	<b>Φ 3:</b>	- 0.0°
<b>WH:</b>	0.000 KWH	<b>SH:</b>	0.000KVAH		
<b>QH:</b>	0.000 KVARH	<b>FREQ:</b>	0.0 Hz		
<b>AUTO</b>	<b>3Φ4W</b>	<b>SEC: 2</b>	<b>CT: 1</b>	<b>PT: 1</b>	<b>NO</b>
<b>20A</b>					<b>DISK</b>

### **4-3 The summary description of keyboard**

- 1) POWER KEY ( 3-7, Fig. 1 ) :  
Press the key to turn the instrument ON/OFF.
- 2) 1 $\Phi$  3 $\Phi$  ( phase/wire ) KEY ( 3-2, Fig. 1 ) :  
Press the key to select  
(1P/2W 、 1P/3W 、 3P/3W 、 3P/4W) measurement  
function mode.
- 3) A ( current ) RANGE KEY ( 3-10, Fig. 1 ) :  
Press the key to change AUTO RANGE to MANUAL  
RANGE mode for current.
- 4) REC KEY ( 3-9, Fig. 1 ) :  
The data record key for SD CARD.
- 5) HOLD KEY ( 3-5, Fig. 1 ) :  
Press the key to freeze the display reading.
- 6) BACKLIGHT KEY ( 3-6, Fig. 1 ) :  
Press the key to switch LCD backlight to ON/OFF.
- 7) SETUP KEY ( 3-12, Fig. 1 ) :  
Press the key to setup the function before measuring.
- 8) EXIT KEY ( 3-8, Fig. 1 ) :  
Press the key to exit setting screen.
- 9) SHIFT KEY ( 3-11, Fig. 1 ) :  
Press the key to set the different functions in setting  
screen.
- 10) UP (▲) KEY ( 3-3, Fig. 1 ) :  
Press the key to move the cursor up in setting  
screen.
- 11) DOWN (▼) KEY ( 3-4, Fig. 1 ) :  
Press the key to move the cursor down in setting  
screen.

## 4-4 SETUP KEY description:

### 4-4-1 SHIFT KEY

- \* SHIFT 1 : When the symbols " SETUP " and " SHIFT 1 " are appeared on up right display of screen 1 in the meantime, and then use the ▲ or ▼ to select the expect item.
- \* SHIFT 2 : When the symbols " SETUP " and " SHIFT 2 " are appeared on up right display of screen 2 in the mean time, and then use the ▲ or ▼ to select ( 1P/2W 、 1P/3W 、 3P/3W 、 3P/4W ) in File Name function.

Folder Name:	WTA01					<b>SETUP</b>
<b>File Name:</b>	3P401001.XLS					<b>SHIFT 1</b> ←
REC Date:	2008-11-28 00:03:17					
Sampling Time:	2					
Delet File:	0 %					
SD Format:	0 %					
Use Size:	388 KB	Decimal:	Basic			
Free Size:	1946 MB	Clamp Type:	1200A			
Total Size:	1946 MB	RS232 Out Sel:				
PT:	1 : 1	V1	I1	P1		
CT:	1 : 1	S1	Q1	PF1		
Beep:	ON	Φ1	WH	FREQ		
Year	Month	Date	Hour	Minute	Second	
2008	12	05	11	15	18	

screen 1 ( 4-4 )

Folder Name:	WTA01					<b>SETUP</b>
<b>File Name:</b>	3P401001.XLS					<b>SHIFT 2</b> ←
REC Date:	2008-11-28 00:03:17					
Sampling Time:	2					
Delet File:	0 %					
SD Format:	0 %					
Use Size:	388 KB	Decimal:	Basic			
Free Size:	1946 MB	Clamp Type:	1200A			
Total Size:	1946 MB	RS232 Out Sel:				
PT:	1 : 1	V1	I1	P1		
CT:	1 : 1	S1	Q1	PF1		
Beep:	ON	Φ1	WH	FREQ		
Year	Month	Date	Hour	Minute	Second	
2008	12	05	11	15	18	

screen 2 ( 4-4 )



## 4-4-2 The Setting Function menu

- \* Folder Name : Set the expect folder name for SD CARD, the range is between WTA01 and WTA10.
- \* File Name: Set the file name for SD CARD, It allows setting 50 filenames in this function.
- \* REC Date: Show the recorded time of existing files ( Year/Month/Date, Hour/Min./Sec. )
- \* Sampling Time : Set the sampling time from 2 to 7200 seconds.
- \* Delete File : To delete the existing data from SD CARD.
- \* SD Format : to Format SD CARD fast.
- \* PT : Set the potential transformer from 1 to 1000.
- \* CT : Set the current transformer from 1 to 600.
- \* Beep : Set to ON/OFF for buzzer.
- \* Clamp Type : Select the Clamp Type to 200A or 1200A.
- \* RS232 out Sel. : Set RS232 output function, maximum up to nine items can be selected to output. screen 1 screen 2.
- \* Year : Set the year.
- \* Month : Set the month.
- \* Date : Set the date.
- \* Hour : Set the hour.
- \* Minute : Set the minute.
- \* Second : Set the second.

## ***4-5 Setting function description before measuring***

Press SETUP KEY to enter setting function screen, the selected item will be displayed in highlight.

### 4-5-1 Folder Name: Set the folder name for SD

screen 1 ( 4-5-1 )

<b>Folder Name:</b> WTA01						<b>SETUP</b>
File Name: 3P401001.XLS						
REC Date: 2008-11-28 00:03:17						
Sampling Time: 2						
Delet File: 0 %						
SD Format: 0 %						
Use Size: 388 KB		Decimal: Basic				
Free Size: 1946 MB		Clamp Type: 1200A				
Total Size: 1946 MB		RS232 Out Sel:				
PT:	1 : 1	V1	I1	P1		
CT:	1 : 1	S1	Q1	PF1		
Beep: ON		Φ1	WH	FREQ		
Year	Month	Date	Hour	Minute	Second	
2008	12	05	11	14	49	

screen 2 ( 4-5-1 )

<b>Folder Name:</b> WTA01						<b>SETUP</b>
File Name: 3P401001.XLS						<b>SHIFT 1</b>
REC Date: 2008-11-28 00:03:17						
Sampling Time: 2						
Delet File: 0 %						
SD Format: 0 %						
Use Size: 388 KB		Decimal: Basic				
Free Size: 1946 MB		Clamp Type: 1200A				
Total Size: 1946 MB		RS232 Out Sel:				
PT:	1 : 1	V1	I1	P1		
CT:	1 : 1	S1	Q1	PF1		
Beep: ON		Φ1	WH	FREQ		
Year	Month	Date	Hour	Minute	Second	
2008	12	05	11	14	34	

- A : Folder Name range: WTA01 to WTA10.
- B : Press ▲ or ▼ to select the expect folder number, the number consists of " 01 to 10 " (as screen 1).
- C : Press ▲ or ▼ continuously at least two seconds can skip the numbers faster.
- D : Press SHIFT KEY once, the symbol " SHIFT1" will appear on up right display, and then press ▼ to entry next setting function as screen 2 (Folder Name → File Name).

#### 4-5-2 File Name: Set the file name for SD

- A : The screen will show " NO File " indicator in REC Date option when the selected file is new ( as screen 1 ).
- B : The screen will show recording date and time in REC Date option when the selected file has been recorded as screen 2.

screen 1 ( 4-5-2 )

	Folder Name: WTA03	<b>SETUP</b>
<b>File Name:</b>	3P401001.XLS	
REC Date:	NO File	
Sampling Time:	2	
Delet File:	0 %	
SD Format:	0 %	
Use Size:	388 KB	Decimal: Basic
Free Size:	1946 MB	Clamp Type: 1200A
Total Size:	1946 MB	RS232 Out Sel:
PT:	1 : 1	V1 I1 P1
CT:	1 : 1	S1 Q1 PF1
Beep: ON		Φ1 WH FREQ
Year	Month	Date
2008	12	05
Hour	Minute	Second
15	10	55

screen 2 ( 4-5-2 )

Folder Name: WTA01						<b>SETUP</b>
→	<b>File Name:</b> 3P401001.XLS					
→	REC Date: 2008-11-28 00:03:17					
	Sampling Time: 2					
	Delet File: 0 %					
	SD Format: 0 %					
	Use Size:	388 KB	Decimal:	Basic		
	Free Size:	1946 MB	Clamp Type:	1200A		
	Total Size:	1946 MB	RS232 Out Sel:			
	PT:	1 : 1	V1	I1	P1	
	CT:	1 : 1	S1	Q1	PF1	
	Beep:	ON	Φ1	WH	FREQ	
	Year	Month	Date	Hour	Minute	Second
	2008	12	05	11	15	31

C : File Name description : press ▲ or ▼ in screen 2 to select expect file number from 001 to 050.

*Remark : When press ▲ or ▼ > 2 sec, the setting no. will change fast.*

- \* 1P201001 : 1P2 means one phase by two wires, 01 means folder number, 001 means file number.
- \* 1P301001: 1P3 means one phase by three wires, 01 means folder number, 001 means file number.
- \* 3P301001 : 3P3 means three phases by three wires, 01 means folder number, 001 means file number.
- \* 3P401001 : 3P4 means three phases by four wires, 01 means folder number, 001 means file number.

D : The up right display will show " SHIFT1 " symbol while pressing SHIFT KEY once in screen 2, and then press ▼ to enter next setting function as screen 3 ( File Name → Sampling Time ).

E : The up right display will show " SHIFT2 " symbol while pressing SHIFT KEY again in screen 4, at this time press ▲ or ▼ to select 1P/2W(1P2) 、 1P/3W(1P3) 、 3P/3W(3P3) and 3P/4W(3P4) as screen 4.

F: One by one to press SHIFT KEY to select different functions circularly.

Folder Name:	WTA01					<b>SETUP</b>
<b>File Name:</b>	3P401001.XLS					<b>SHIFT 1</b>
REC Date:	2008-11-28 00:03:17					← screen 3 (4-5-2)
Sampling Time:	2					
Delet File:	0 %					
SD Format:	0 %					
Use Size:	388 KB	Decimal:	Basic			
Free Size:	1946 MB	Clamp Type:	1200A			
Total Size:	1946 MB	RS232 Out Sel:				
PT:	1 : 1	V1	I1	P1		
CT:	1 : 1	S1	Q1	PF1		
Beep:	ON	Φ1	WH	FREQ		
Year	Month	Date	Hour	Minute	Second	
2008	12	05	11	15	06	

Folder Name:	WTA01					<b>SETUP</b>
<b>File Name:</b>	3P401001.XLS					<b>SHIFT 2</b>
REC Date:	2008-11-28 00:03:17					← screen 4 ( 4-5-2 )
Sampling Time:	2					
Delet File:	0 %					
SD Format:	0 %					
Use Size:	388 KB	Decimal:	Basic			
Free Size:	1946 MB	Clamp Type:	1200A			
Total Size:	1946 MB	RS232 Out Sel:				
PT:	1 : 1	V1	I1	P1		
CT:	1 : 1	S1	Q1	PF1		
Beep:	ON	Φ1	WH	FREQ		
Year	Month	Date	Hour	Minute	Second	
2008	12	05	11	15	18	

**4-5-3 Sampling time: Set the data logger sampling time for SD**

A : When press SHIFT KEY once, the symbol " SHIFT1 " will disappear on up right display, at this time press ▲ or ▼ to adjust expect sampling time as screen 2, adjusting numbers are from 2 to 7200 seconds.

*Remark : When press ▲ or ▼ > 2 sec, the setting no. will change fast.*

B : The up right display will show " SHIFT1 " symbol while pressing SHIFT KEY again, and then press ▼ to enter next setting function (Sampling Time → Delete File)

screen 1 ( 4-5-3 )

Folder Name:	WTA01					<b>SETUP</b>
File Name:	3P401001.XLS					<b>SHIFT 1</b> ←
REC Date:	2008-11-28 00:03:17					
<b>Sampling Time:</b>	2					
Delet File:	0 %					
SD Format:	0 %					
Use Size:	388 KB	Decimal:	Basic			
Free Size:	1946 MB	Clamp Type:	1200A			
Total Size:	1946 MB	RS232 Out Sel:				
PT:	1 : 1	V1	I1	P1		
CT:	1 : 1	S1	Q1	PF1		
Beep:	ON	Φ1	WH	FREQ		
Year	Month	Date	Hour	Minute	Second	
2008	12	05	11	15	51	

screen 2 ( 4-5-3 )

Folder Name:	WTA01					<b>SETUP</b>
File Name:	3P401001.XLS					
REC Date:	2008-11-28 00:03:17					
<b>Sampling Time:</b>	2					
Delet File:	0 %					
SD Format:	0 %					
Use Size:	388 KB	Decimal:	Basic			
Free Size:	1946 MB	Clamp Type:	1200A			
Total Size:	1946 MB	RS232 Out Sel:				
PT:	1 : 1	V1	I1	P1		
CT:	1 : 1	S1	Q1	PF1		
Beep:	ON	Φ1	WH	FREQ		
Year	Month	Date	Hour	Minute	Second	
2008	12	05	11	16	01	

### 4-5-4 Delete File: Delete the files for SD

A : The indicator " Y or N " will appear on right side display of the option while pressing SHIFT KEY continuously at least two seconds, and now press ▲ the display will show " Y " in highlight as screen 2, press SETUP KEY again to confirm, the selected file (ex: 3P401001.XLS) will be erased then return to screen 1, or else press SETUP KEY in " Y or N " option to return to screen 1.

B : Press ▼ in screen 1 to enter next setting function (Delete File → SD Format)

screen 1 ( 4-5-4 )

Folder Name:	WTA01					<b>SETUP SHIFT 1</b>
File Name:	3P401001.XLS					
REC Date:	2008-11-28 00:03:17					
Sampling Time:	2					
<b>Delete File:</b>	0 %					
SD Format:	0 %					
Use Size:	388	KB	Decimal:	Basic		
Free Size:	1946	MB	Clamp Type:	1200A		
Total Size:	1946	MB	RS232 Out Sel:			
PT:	1 : 1		V1	I1	P1	
CT:	1 : 1		S1	Q1	PF1	
Beep:	ON		Φ1	WH	FREQ	
Year	Month	Date	Hour	Minute	Second	
2008	12	05	11	16	20	

screen 2 ( 4-5-4 )

Folder Name:	WTA01					<b>SETUP SHIFT 1</b>
File Name:	3P401001.XLS					
REC Date:	2008-11-28 00:03:17					
Sampling Time:	2					
→ <b>Delete File:</b>	Y OR N					
SD Format:	0 %					
Use Size:	388	KB	Decimal:	Basic		
Free Size:	1946	MB	Clamp Type:	1200A		
Total Size:	1946	MB	RS232 Out Sel:			
PT:	1 : 1		V1	I1	P1	
CT:	1 : 1		S1	Q1	PF1	
Beep:	ON		Φ1	WH	FREQ	
Year	Month	Date	Hour	Minute	Second	
2008	12	05	11	16	45	

#### 4-5-5 SD Format : Formatting function for SD CARD

- A : The indicator " Y or N " will appear on right side display of the option while pressing SHIFT KEY continuously at least two seconds, and press ▲ the display will show " Y " in highlight as screen 2, press SETUP KEY again to confirm to format SD CARD then return to screen 1, or else press SETUP KEY in " Y OR N " option return to screen 1.
- B : Press ▼ in screen 1 to enter next setting function ( SD Format → PT ).



screen 1 ( 4-5-5 )

Folder Name:	WTA01					<b>SETUP SHIFT 1</b>
File Name:	3P401001.XLS					
REC Date:	2008-11-28 00:03:17					
Sampling Time:	2					
Delete File:	0 %					
<b>SD Format:</b>	0 %					
Use Size:	388 KB	Decimal:	Basic			
Free Size:	1946 MB	Clamp Type:	1200A			
Total Size:	1946 MB	RS232 Out Sel:				
PT:	1 : 1	V1	I1	P1		
CT:	1 : 1	S1	Q1	PF1		
Beep:	ON	Φ1	WH	FREQ		
Year	Month	Date	Hour	Minute	Second	
2008	12	05	11	17	05	

screen 2 ( 4-5-5 )

Folder Name:	WTA01					<b>SETUP SHIFT 1</b>
File Name:	3P401001.XLS					
REC Date:	2008-11-28 00:03:17					
Sampling Time:	2					
Delete File:	0 %					
<b>SD Format:</b>	Y OR N					
Use Size:	388 KB	Decimal:	Basic			
Free Size:	1946 MB	Clamp Type:	1200A			
Total Size:	1946 MB	RS232 Out Sel:				
PT:	1 : 1	V1	I1	P1		
CT:	1 : 1	S1	Q1	PF1		
Beep:	ON	Φ1	WH	FREQ		
Year	Month	Date	Hour	Minute	Second	
2008	12	05	11	17	20	

### 4-5-6 PT: Set the Potential Transformer

A : When press SHIFT KEY once, the symbol " SHIFT1 " will disappear as screen 2 at this time press ▲ or ▼ can adjust to expect PT values, the adjusting numbers are from 1 to 1000.

*Remark : When press ▲ or ▼ > 2 sec, the setting no. will change fast.*

B : Press SHIFT KEY once again will return to screen 1 then press ▼ to enter next setting function ( PT → CT ).

screen 1 ( 4-5-6 )

Folder Name:	WTA01					<b>SETUP</b> <b>SHIFT 1</b>
File Name:	3P401001.XLS					
REC Date:	2008-11-28 00:03:17					
Sampling Time:	2					
Delete File:	0 %					
SD Format:	0 %					
Use Size:	388	KB	Decimal:	Basic		
Free Size:	1946	MB	Clamp Type:	1200A		
Total Size:	1946	MB	RS232 Out Sel:			
<b>PT:</b>	1 : 1		V1	I1	P1	
CT:	1 : 1		S1	Q1	PF1	
Beep:	ON		Φ1	WH	FREQ	
Year	Month	Date	Hour	Minute	Second	
2008	12	05	11	17	53	

screen 2 ( 4-5-6 )

Folder Name: WTA01						<b>SETUP</b>
File Name: 3P401001.XLS						
REC Date: 2008-11-28 00:03:17						
Sampling Time: 2						
Delete File: 0 %						
SD Format: 0 %						
Use Size: 388 KB		Decimal: Basic				
Free Size: 1946 MB		Clamp Type: 1200A				
Total Size: 1946 MB		RS232 Out Sel:				
<b>PT:</b>	1 : 1	V1	I1	P1		
CT:	1 : 1	S1	Q1	PF1		
Beep: ON		Φ1	WH	FREQ		
Year	Month	Date	Hour	Minute	Second	
2008	12	05	11	19	07	

#### 4-5-7 CT: Set the Current Transformer

A : When press SHIFT KEY once, the symbol " SHIFT1 " will disappear as screen 2 at this time press ▲ or ▼ can adjust to expect CT values, the adjusting numbers are from 1 to 600.

*Remark : When press ▲ or ▼ > 2 sec, the setting no. will change fast.*

B : Press SHIFT KEY once again will return to screen 1 then press ▼ to enter next setting function ( CT → BEEP ). again will return to screen 1 then press ▼ to enter next setting function ( CT → BEEP ).

screen 1 ( 4-5-7 )

Folder Name:	WTA01					<b>SETUP</b> <b>SHIFT 1</b>
File Name:	3P401001.XLS					
REC Date:	2008-11-28 00:03:17					
Sampling Time:	2					
Delete File:	0 %					
SD Format:	0 %					
Use Size:	388	KB	Decimal:	Basic		
Free Size:	1946	MB	Clamp Type:	1200A		
Total Size:	1946	MB	RS232 Out Sel:			
PT:	1 : 1		V1	I1	P1	
<b>CT:</b>	1 : 1		S1	Q1	PF1	
Beep:	ON		Φ1	WH	FREQ	
Year	Month	Date	Hour	Minute	Second	
2008	12	05	11	19	20	

screen 2 ( 4-5-7 )

Folder Name:	WTA01					<b>SETUP</b>
File Name:	3P401001.XLS					
REC Date:	2008-11-28 00:03:17					
Sampling Time:	2					
Delete File:	0 %					
SD Format:	0 %					
Use Size:	388	KB	Decimal:	Basic		
Free Size:	1946	MB	Clamp Type:	1200A		
Total Size:	1946	MB	RS232 Out Sel:			
PT:	1 : 1		V1	I1	P1	
<b>CT:</b>	1 : 1		S1	Q1	PF1	
Beep:	ON		Φ1	WH	FREQ	
Year	Month	Date	Hour	Minute	Second	
2008	12	05	11	19	30	

### 4-5-8 Beep: Control the buzzer to ON/OFF

A : When press SHIFT KEY once the symbol " SHIFT1 " will disappear as screen 2, at this time press ▲ or ▼ to control the buzzer to ON/OFF.

B : Press SHIFT KEY once again will return to screen 1 then press ▼ to enter next setting function ( BEEP → Decimal type )

screen 1 ( 4-5-8 )

Folder Name:	WTA01					<b>SETUP SHIFT 1</b>
File Name:	3P401001.XLS					
REC Date:	2008-11-28 00:03:17					
Sampling Time:	2					
Delete File:	0 %					
SD Format:	0 %					
Use Size:	388	KB	Decimal:	Basic		
Free Size:	1946	MB	Clamp Type:	1200A		
Total Size:	1946	MB	RS232 Out Sel:			
PT:	1 : 1		V1	I1	P1	
CT:	1 : 1		S1	Q1	PF1	
<b>Beep:</b>	ON		Φ1	WH	FREQ	
Year	Month	Date	Hour	Minute	Second	
2008	12	05	11	19	44	

screen 2 ( 4-5-8 )

Folder Name:	WTA01					<b>SETUP</b>
File Name:	3P401001.XLS					
REC Date:	2008-11-28 00:03:17					
Sampling Time:	2					
Delete File:	0 %					
SD Format:	0 %					
Use Size:	388	KB	Decimal:	Basic		
Free Size:	1946	MB	Clamp Type:	1200A		
Total Size:	1946	MB	RS232 Out Sel:			
PT:	1 : 1	V1	I1	P1		
CT:	1 : 1	S1	Q1	PF1		
<b>Beep:</b>	ON	Φ1	WH	FREQ		
Year	Month	Date	Hour	Minute	Second	
2008	12	05	11	19	58	

4-5-9 Decimal Type: set the Decimal type to Basic ( . ) or Euro ( , )



**The numerical data structure of SD card is default used the " . " as the decimal, for example "20.6" "1000.53" . But in certain countries ( Europe ...) is used the " , " as the decimal point, for example " 20,6 " "1000,53". Under such situation, it should change the Decimal character at first.**

A : When press SHIFT KEY once the symbol " SHIFT1 " will disappear as screen 2, at this time press ▲ or ▼ to select the Decimal type to " Basic " or " Euro " .

*\* Basic type :*

*The numerical data structure of SD card is default used the " . " as the decimal, for example "20.6" "1000.53" .*

*\* Euro type :*

*The numerical data structure of SD card is default used the " , " as the decimal, for example "20,6" "1000,53" .*

B : Press SHIFT KEY once again will return to screen 1 then press ▼ to enter next setting function ( Decimal type → Clamp type ).

screen 1 ( 4-5-9 )

Folder Name:	WTA01	<b>SETUP</b> <b>SHIFT 1</b>			
File Name:	3P401001.XLS				
REC Date:	2008-11-28 00:03:17				
Sampling Time:	2				
Delete File:	0 %				
SD Format:	0 %				
Use Size:	388 KB	<b>Decimal :</b>	Basic		
Free Size:	1946 MB	Clamp Type:	1200A		
Total Size:	1946 MB	RS232 Out Sel:			
PT:	1 : 1	V1	I1	P1	
CT:	1 : 1	S1	Q1	PF1	
Beep:	ON	Φ1	WH	FREQ	
Year	Month	Date	Hour	Minute	Second
2008	12	05	11	20	18

screen 2 ( 4-5-9 )

Folder Name: WTA01						<b>SETUP</b>
File Name: 3P401001.XLS						
REC Date: 2008-11-28 00:03:17						
Sampling Time: 2						
Delete File: 0 %						
SD Format: 0 %						
Use Size: 388 KB		<b>Decimal :</b>		Basic		
Free Size: 1946 MB		Clamp Type:		1200A		
Total Size: 1946 MB		RS232 Out Sel:				
PT: 1 : 1		V1 I1		P1		
CT: 1 : 1		S1 Q1		PF1		
Beep: ON		Φ1 WH		FREQ		
Year	Month	Date	Hour	Minute	Second	
2008	12	05	11	20	18	

4-5-10 Clamp Type: set the clamp type to 200A or 1200A

- A : When press SHIFT KEY once the symbol " SHIFT1 " will disappear as screen 2, at this time press ▲ or ▼ to select the CT type to 200A or 1200A.
- B : Press SHIFT KEY once again will return to screen 1 then press ▼ to enter next setting function ( CLAMP TYPE → RS232 OUT SEL ).



screen 1 ( 4-5-10 )

Folder Name:	WTA01					<b>SETUP</b> <b>SHIFT 1</b>
File Name:	3P401001.XLS					
REC Date:	2008-11-28 00:03:17					
Sampling Time:	2					
Delete File:	0 %					
SD Format:	0 %					
Use Size:	388	KB	Decimal:	Basic		
Free Size:	1946	MB	<b>Clamp Type:</b>	1200A		
Total Size:	1946	MB	RS232 Out Sel:			
PT:	1 : 1		V1	I1	P1	
CT:	1 : 1		S1	Q1	PF1	
Beep:	ON		Φ1	WH	FREQ	
Year	Month	Date	Hour	Minute	Second	
2008	12	05	11	20	18	

screen 2 ( 4-5-10 )

Folder Name:	WTA01					<b>SETUP</b>
File Name:	3P401001.XLS					
REC Date:	2008-11-28 00:03:17					
Sampling Time:	2					
Delete File:	0 %					
SD Format:	0 %					
Use Size:	388	KB	Decimal:	Basic		
Free Size:	1946	MB	<b>Clamp Type:</b>	1200A		
Total Size:	1946	MB	RS232 Out Sel:			
PT:	1 : 1		V1	I1	P1	
CT:	1 : 1		S1	Q1	PF1	
Beep:	ON		Φ1	WH	FREQ	
Year	Month	Date	Hour	Minute	Second	
2008	12	05	11	19	44	

### 4-5-11 RS232 Out Sel setting

- A : When press SHIFT KEY continuously at least two seconds as screen 2 and now press ▲ or ▼ to select the item that intend to output, maximum up to nine items, when the cursor stops on the selected item and then press SHIFT KEY again, the selected item will be displayed in highlight.
- B : If the selected items are over nine, the low right display will show indicator " full " as screen 3.
- C : After the selecting is completed, press SHIFT KEY continuously at least two seconds again will return to screen 1 and show all the selected items at the same time.
- D : Press ▼ in screen 1 to enter next setting function ( RS232 Out Sel → Year )

screen 1 ( 4-5-11 )

Folder Name:	WTA01					<b>SETUP SHIFT 1</b>
File Name:	3P401001.XLS					
REC Date:	2008-11-28 00:03:17					
Sampling Time:	2					
Delete File:	0 %					
SD Format:	0 %					
Use Size:	388	KB	Decimal:	Basic		
Free Size:	1946	MB	Clamp Type:	1200A		
Total Size:	1946	MB	<b>RS232 Out Sel:</b>			
PT:	1 : 1	V1	I1	P1		
CT:	1 : 1	S1	Q1	PF1		
Beep:	ON	Φ1	WH	FREQ		
Year	Month	Date	Hour	Minute	Second	
2008	12	05	11	20	43	

screen 2 ( 4-5-11 )

## RS232 OUTPUT SELECT

- |               |                |                 |
|---------------|----------------|-----------------|
| 1. V12        | 12. P3         | 23. PF2         |
| 2. V23        | 13. PΣ         | 24. PF3         |
| 3. V31        | 14. <b>S1</b>  | 25. PFΣ         |
| <b>4. V1</b>  | 15. S2         | 26. PFH         |
| 5. V2         | 16. S3         | 27. <b>Φ 1</b>  |
| 6. V3         | 17. SΣ         | 28. Φ 2         |
| 7. <b>I1</b>  | 18. <b>Q1</b>  | 29. Φ 3         |
| 8. I2         | 19. Q2         | 30. <b>WH</b>   |
| 9. I3         | 20. Q3         | 31. SH          |
| 10. <b>P1</b> | 21. QΣ         | 32. QH          |
| 11. P2        | 22. <b>PF1</b> | 33. <b>FREQ</b> |

screen 3 ( 4-5-11 )

## RS232 OUTPUT SELECT

- |               |                |                 |
|---------------|----------------|-----------------|
| 1. V12        | 12. P3         | 23. PF2         |
| 2. V23        | 13. PΣ         | 24. PF3         |
| 3. V31        | 14. <b>S1</b>  | 25. PFΣ         |
| <b>4. V1</b>  | 15. S2         | 26. PFH         |
| 5. V2         | 16. S3         | 27. <b>Φ 1</b>  |
| 6. V3         | 17. SΣ         | 28. Φ 2         |
| 7. I1         | 18. <b>Q1</b>  | 29. Φ 3         |
| 8. I2         | 19. Q2         | 30. <b>WH</b>   |
| 9. I3         | 20. Q3         | 31. SH          |
| 10. <b>P1</b> | 21. QΣ         | 32. QH          |
| 11. P2        | 22. <b>PF1</b> | 33. <b>FREQ</b> |
|               |                | <b>FULL</b>     |

**4-5-12 Year/Month/Date/Hour/Minute/Second setting**

- A : When press SHIFT KEY once the symbol " SHIFT1" will disappear as screen 2, at this time press ▲ or ▼ to adjust expect numbers, and press ▲ or ▼ continuously at least two seconds can skip the numbers faster.
- B : Press ▼ in screen 1 to enter next setting function ( Year → Month ).
- C : The settings about ( Month → Date ), (Date → Hour ), (Hour → Minute ), ( Minute → Second ) are same as above step A and step B.
- D : In this setting function ( Year → Minute ), press ▲ or ▼ in addition to adjust the numbers, and the setting value will also be saved during the adjusting.
- E : In the function of setting " second ", press ▲ or ▼ to adjust numbers. at this point the number of second is at a standstill condition and then press setup key that will save setting value and also start counting function of " second ".

Folder Name:	WTA01					<b>SETUP SHIFT 1</b>
File Name:	3P401001.XLS					
REC Date:	2008-11-28 00:03:17					
Sampling Time:	2					
Delete File:	0 %					
SD Format:	0 %					
Use Size:	388	KB	Decimal:	Basic		
Free Size:	1946	MB	Clamp Type:	1200A		
Total Size:	1946	MB	RS232 Out Sel:			
PT:	1 : 1		V1	I1	P1	
CT:	1 : 1		S1	Q1	PF1	
Beep:	ON		Φ 1	WH	FREQ	
<b>Year</b>	Month	Date	Hour	Minute	Second	
2008	12	05	12	02	13	

screen 1  
( 4-5-12 )

Folder Name: WTA01						<b>SETUP</b>
File Name: 3P401001.XLS						
REC Date: 2008-11-28 00:03:17						
Sampling Time: 2						
Delete File: 0 %						
SD Format: 0 %						
Use Size: 388 KB		Decimal: Basic				
Free Size: 1946 MB		Clamp Type: 1200A				
Total Size: 1946 MB		RS232 Out Sel:				
PT: 1 : 1		V1 I1		P1		
CT: 1 : 1		S1 Q1		PF1		
Beep: ON		Φ 1 WH		FREQ		
<b>Year</b>	Month	Date	Hour	Minute	Second	
2008	12	05	12	02	28	

screen 2  
( 4-5-12 )

4-5-13 When all settings are completed, press EXIT KEY to return measuring screen.

4-5-14 The descriptions about SD CARD memory space

- A : Use Size - To show the space data numbers that have been used.
- B : Free Size - To show the data numbers of balance space.
- C : Total Size - To show the data numbers of total space.
- D : Typical SD CARD and SDHC both can be used with the instrument, except the SD CARD memory size is less than 32MB.

4-5-15 RESET KEY : Press this key to reboot the instrument

# 5. Measuring Procedures

## 5-1 1 $\Phi$ 2W ( one phase by two wires ) measurement

A : Diagram

SCREEN 1 ( 5-1 )

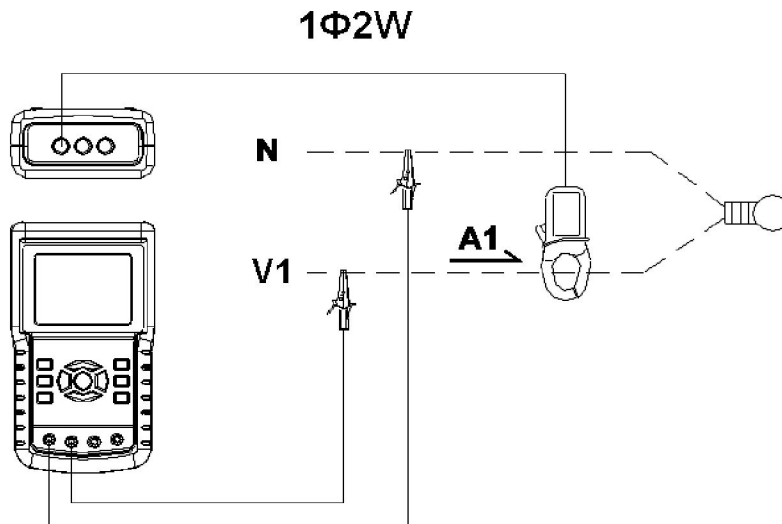

B : Operation Instructions:

B-1 : Power on the instrument by pressing POWER KEY, and then press 1 $\Phi$  3 $\Phi$  KEY to select the 1 $\Phi$  2W system, the selected name of system will be appeared on bottom left display of screen 2.

B-2 : Connect the line voltage L1, Vn ( Neutral ) to V1 and N terminals of the instrument.

B-3: Place the conductor of CP-1200 (A1)to A1 as screen 1.

B-4: Connect the output of clamp meter " CP-1200(A1) " to A1 terminal of the instrument.

B-5: The related measuring factors will be appeared on display, about the instruction of factor please refer appendix 1 ( 5-11, page 49 ).

screen 2 ( 5-1 )

V 1 :	0.0	V			
A 1 :	0.00	A			
P 1 :	- 0.000KW		P F 1 :	- 0.00	
S 1 :	0.000KVA		P F H :	0.00	
Q 1 :	- 0.000KVAR		Φ 1 :	- 0.0°	
W H :	0.000KWH				
S H :	0.000KVAH				
Q H :	0.000KVARH		F R E Q :	50.1	Hz

\*\*

**AUTO**  
**20A**   **1Φ 2W**   **SEC: 2**   **CT: 1**   **PT: 1**

### 5-2 1Φ3W (one phase by three wires) measurement

A : Diagram

screen1 ( 5-2 )

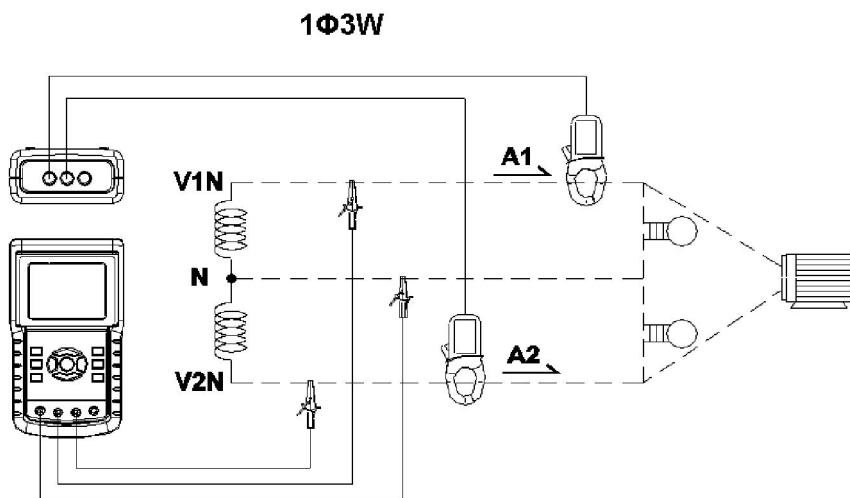

**B : Operation Instructions:**

B-1 : Power on the instrument by pressing POWER KEY, and then press 1Φ 3Φ KEY to select the 1Φ 3W system, the selected name of system will be appeared on bottom left display of screen 2.

B-2 : Connect the line voltage L1, L2 and Vn (Neutral) to V1, V2 and N terminals of the instrument.

B-3 : Place the conductor of CP-1200(A1), CP-1200(A2) hook to A1 and A2 as screen 1.

B-4 : Connect the outputs of clamp meter CP-1200(A1) \ CP-1200(A2) to A1 and A2 terminals of the instrument.

B-5 : The related measuring factors will be appeared on display, about the instruction of factor please refer appendix 1 ( 5-11, page 49 ).

screen 2 ( 5-2 )

V 1 :	0.0	V	P 1 :	-	0.000KW
V 2 :	0.0	V	P 2 :	-	0.000KW
A 1 :	0.00	A	S 1 :		0.000KVA
A 2 :	0.00	A	S 2 :		0.000KVA
Q 1 :	-	0.000KVAR			
Q 2 :	-	0.000KVAR			
<b>PΣ :</b>	0.000	KW	<b>SΣ :</b>	0.000	KVA
<b>PF1:</b>	-	0.00	<b>PF2:</b>	-	0.00
<b>PFH:</b>		0.00	<b>Φ 1:</b>	-	0.0°
			<b>Φ 2:</b>	-	0.0°
<b>WH:</b>	0.000	KWH	<b>SH:</b>	0.000	KVAH
<b>QH:</b>	0.000	KVARH	<b>FREQ:</b>	50.0	Hz
<b>AUTO</b>					
<b>20A</b>	<b>1Φ3W</b>		<b>SEC: 2</b>	<b>CT: 1</b>	<b>PT: 1</b>



## **5-3 3 $\Phi$ 3W (three phases by three wires) measurement**

A : Diagram

screen 1 ( 5-3 )

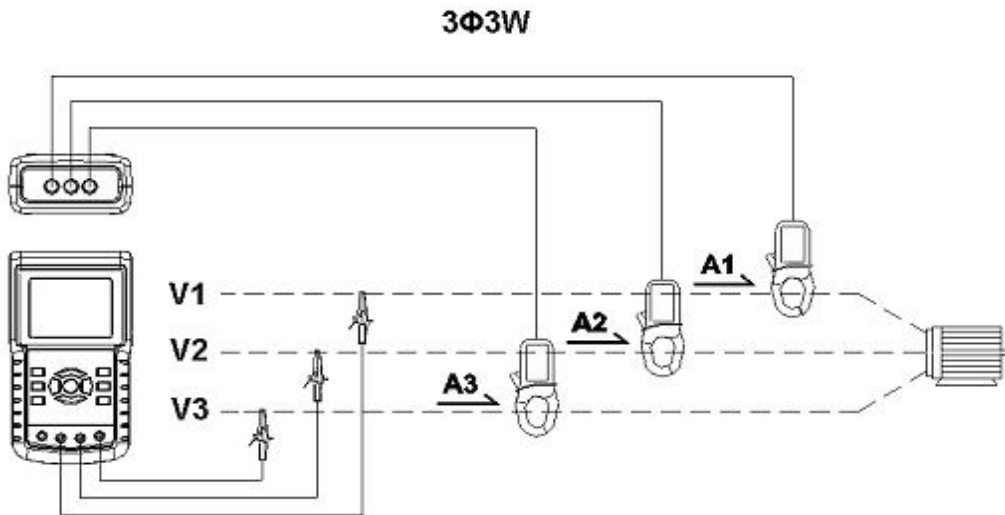

B : Operation Instructions:

B-1 : Power on the instrument by pressing POWER KEY, and then press 1 $\Phi$  3 $\Phi$  KEY to select the 3 $\Phi$  3W system, the selected name of system will be appeared on bottom left display of screen 2.

B-2: Connect the line voltage L1, L2 and L3 to V1, V2 and V3 terminals of the instrument.

B-3: Place the conductor of CP-1200(A1), CP-1200(A2), CP-1200(A3) hook to A1, A2 ,A3 as screen 1.

B-4 : Connect the outputs of clamp meter CP-1200(A1) , CP-1200(A2), CP-1200(A3) to A1, A2, A3 terminals of the instrument.

B-5: The related measuring factors will be appeared on display, about the instruction of factor please refer appendix 1 ( 5-11, page 49 ).

screen 2 ( 5-3 )

V 1 2 :	0.0	V	A 1 :	0.00	A
V 2 3 :	0.0	V	A 2 :	0.00	A
V 3 1 :	0.0	V	A 3 :	0.00	A
P Σ :	-	0.000	K W		
S Σ :		0.000	K V A		
Q Σ :		0.000	K V A R		
PF Σ :		0.00	P F H : 0.00		
<b>WH:</b>	0.000	K W H	<b>SH:</b>	0.000	K V A H
<b>QH:</b>	0.000	K V A R H	<b>FREQ:</b>	50.0	H z
<b>AUTO</b>	<b>20A</b>	<b>3Φ3W</b>	<b>SEC: 2</b>	<b>CT: 1</b>	<b>PT: 1</b>

### ***5-4 3Φ4W (three phases by four wires) measurement***

A : Diagram

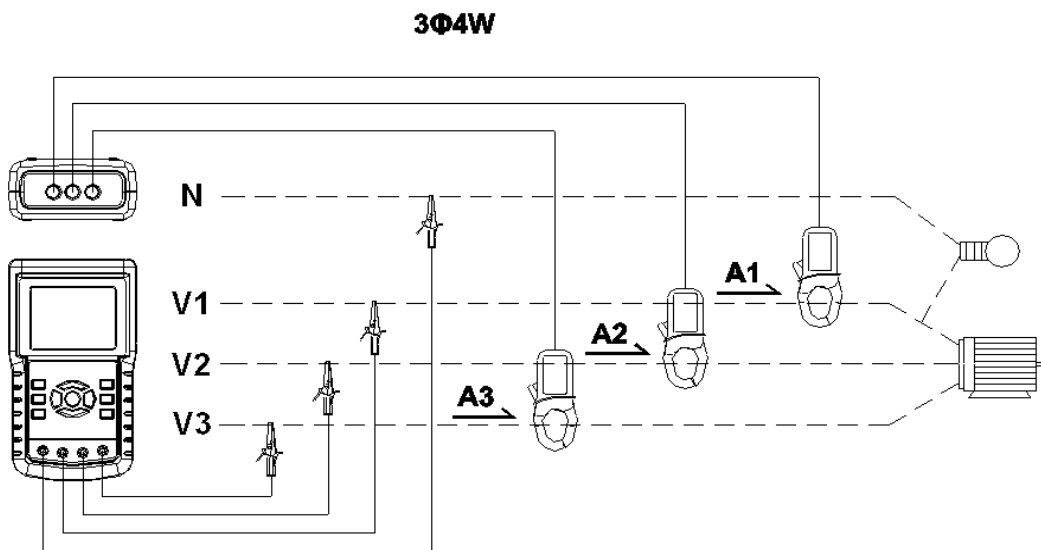

screen 1 ( 5-4 )

## B: Operation Instructions:

B-1 : Power on the instrument by pressing POWER KEY, and then press 1Φ 3Φ KEY to select the 3Φ 4W system, the selected name of system will be appeared on bottom left display of screen 2.

B-2 : Connect the line voltage L1, L2, L3 and Vn to V1, V2, V3 and N terminals of the instrument.

B-3 : Place the conductor of CP-1200(A1), CP-1200(A2) 、 CP-1200(A3) hook to A1, A2, A3 as screen 1.

B-4 : Connect the outputs of clamp meter CP-1200(A1), CP-1200(A2), CP-1200(A3) to A1 、 A2 、 A3 terminals of the instrument.

B-5 : The related measuring factors will be appeared on display, about the instruction of factor please refer appendix 1 ( 5-11, page 49 ).

screen 2 ( 5-4 )

<b>V12:</b> 0.0 V	<b>V1:</b> 0.0 V	<b>A1:</b> 0.00 A
<b>V23:</b> 0.0 V	<b>V2:</b> 0.0 V	<b>A2:</b> 0.00 A
<b>V31:</b> 0.0 V	<b>V3:</b> 0.0 V	<b>A3:</b> 0.00 A
<b>P1:</b> - 0.000 KW	<b>S1:</b> 0.000 KVA	<b>Q1:</b> - 0.000 KVAR
<b>P2:</b> - 0.000 KW	<b>S2:</b> 0.000 KVA	<b>Q2:</b> - 0.000 KVAR
<b>P3:</b> - 0.000 KW	<b>S3:</b> 0.000 KVA	<b>Q3:</b> - 0.000 KVAR
<b>PΣ</b> - 0.000 KW	<b>SΣ :</b> 0.000 KVA	<b>QΣ :</b> - 0.000 KVAR
<b>PF1:</b> - 0.00	<b>PF2:</b> - 0.00	<b>PF3:</b> - 0.00
<b>PFΣ :</b> 0.00	<b>PFH:</b> 0.00	
<b>Φ 1:</b> - 0.0°	<b>Φ 2:</b> - 0.0°	<b>Φ 3:</b> - 0.0°
<b>WH:</b> 0.000 KWH	<b>SH:</b> 0.000 KVAH	
<b>QH:</b> 0.000 KVARH	<b>FREQ:</b> 0.0 Hz	
<b>AUTO</b>		
<b>20A</b>	<b>3Φ 4W</b>	<b>SEC: 2</b>
	<b>CT: 1</b>	<b>PT: 1</b>

## 5-5 The CT and PT measurement

A : Diagram

screen 1 ( 5-5 )

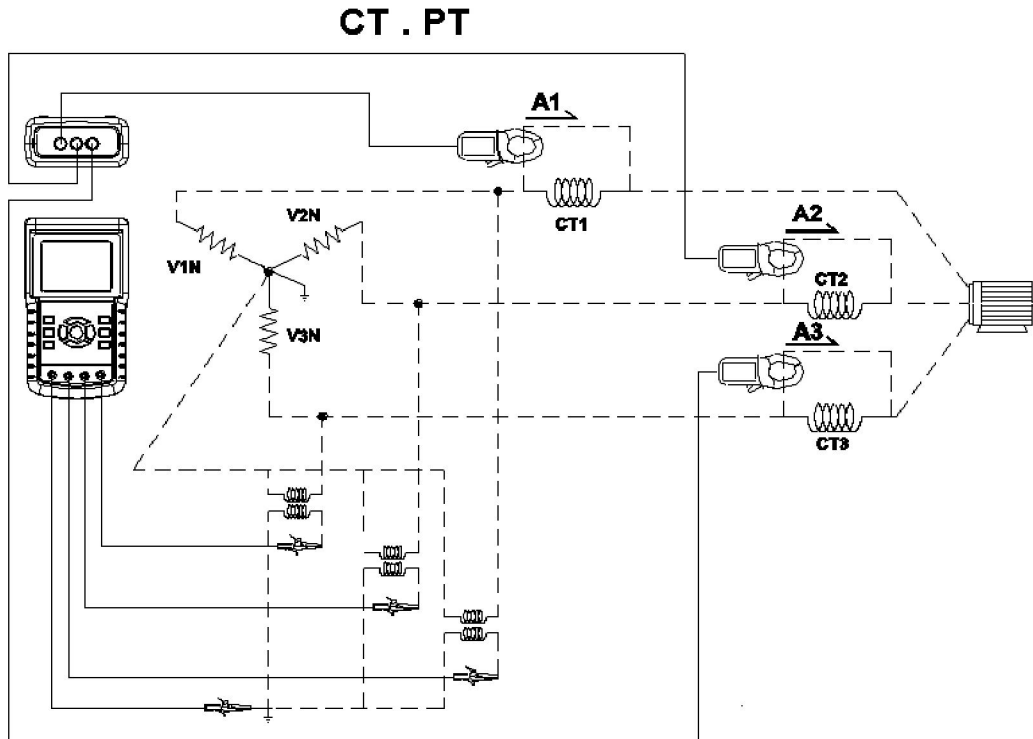

B : Operation Instructions

B-1 : Power on the instrument by pressing POWER KEY, and then press 1Φ 3Φ KEY to select the 3Φ 4W system, the selected name of system will be appeared on bottom left display of screen 2.

B-2 : Connect the line voltage L1, L2, L3 and Vn to V1, V3 and N terminals of the instrument.

B-3 : Place the conductor of CP-1200(A1), CP-1200(A2), CP-1200(A3) hook to A1, A2 , A3 as screen 1.

B-4: Connect the outputs of clamp meter CP-1200(A1), CP-1200(A2), CP-1200(A3) to A1, A2, A3 terminals of the instrument.

B-5: The related measuring factors will be appeared on display, about the instruction of factor please refer appendix 1 ( 5-11, page 49 ).

screen 2 ( 5-5 )

<b>V12:</b> 0.0 V	<b>V1:</b> 0.0 V	<b>A1:</b> 0.00 A
<b>V23:</b> 0.0 V	<b>V2:</b> 0.0 V	<b>A2:</b> 0.00 A
<b>V31:</b> 0.0 V	<b>V3:</b> 0.0 V	<b>A3:</b> 0.00 A
<b>P1:</b> - 0.000 KW	<b>S1:</b> 0.000 KVA	<b>Q1:</b> - 0.000 KVAR
<b>P2:</b> - 0.000 KW	<b>S2:</b> 0.000 KVA	<b>Q2:</b> - 0.000 KVAR
<b>P3:</b> - 0.000 KW	<b>S3:</b> 0.000 KVA	<b>Q3:</b> - 0.000 KVAR
<b>PΣ</b> - 0.000 KW	<b>SΣ :</b> 0.000 KVA	<b>QΣ :</b> - 0.000 KVAR
<b>PF1:</b> - 0.00	<b>PF2:</b> - 0.00	<b>PF3:</b> - 0.00
<b>PFΣ :</b> 0.00	<b>PFH:</b> 0.00	
<b>Φ 1:</b> - 0.0°	<b>Φ 2:</b> - 0.0°	<b>Φ 3:</b> - 0.0°
<b>WH:</b> 0.000 KWH	<b>SH:</b> 0.000 KVAH	
<b>QH:</b> 0.000 KVARH	<b>FREQ:</b> 0.0 Hz	
<b>AUTO</b>		
<b>20A</b>	<b>3Φ4W</b>	<b>SEC: 2</b>
		<b>CT: 1</b>
		<b>PT: 1</b>

### ***5-6 ZERO adjustment for Watt Hour***

If reset the " Exit key button " ( 3-8, Fig. 1 ) continuously and > 6 seconds, the measurement value of " WH ", " SH ", " QH " will reset to Zero value.

### ***5-7 Data Logger Function***

A : Press REC KEY once to start the data record function.

A-1 : If the bottom right shows as " Change Card ", it indicates the memory space is already full either or the SD CARD exist some wrong.

A-2 : If the SD CARD is normal, the data logger function will start to be executed.

<b>V12:</b>	0.0 V	<b>V1:</b>	0.0 V	<b>A1:</b>	0.00 A
<b>V23:</b>	0.0 V	<b>V2:</b>	0.0 V	<b>A2:</b>	0.00 A
<b>V31:</b>	0.0 V	<b>V3:</b>	0.0 V	<b>A3:</b>	0.00 A
<b>P1:</b>	- 0.000 KW	<b>S1:</b>	0.000 KVA	<b>Q1:</b>	- 0.000 KVAR
<b>P2:</b>	- 0.000 KW	<b>S2:</b>	0.000 KVA	<b>Q2:</b>	- 0.000 KVAR
<b>P3:</b>	- 0.000 KW	<b>S3:</b>	0.000 KVA	<b>Q3:</b>	- 0.000 KVAR
<b>PΣ</b>	- 0.000 KW	<b>SΣ :</b>	0.000 KVA	<b>QΣ :</b>	- 0.000 KVAR
<b>PF1:</b>	- 0.00	<b>PF2:</b>	- 0.00	<b>PF3:</b>	- 0.00
<b>PFΣ :</b>	0.00	<b>PFH:</b>	0.00		
<b>Φ 1:</b>	- 0.0°	<b>Φ 2:</b>	- 0.0°	<b>Φ 3:</b>	- 0.0°
<b>WH:</b>	0.000 KWH	<b>SH:</b>	0.000 KVAH		
<b>QH:</b>	0.000 KVARH	<b>FREQ:</b>	0.0 Hz		
<b>AUTO</b>				<b>Change</b>	
<b>20A</b>	<b>3Φ4W</b>	<b>SEC: 2</b>	<b>CT: 1</b>	<b>PT: 1</b>	<b>Card</b>

B : The bottom right display will show the recorded data points.

B-1 : Each file can record up to 30,000 data points as screen 1 when the record points exceed 30,000 points, system will create a new file automatically. (For example, WTA01001.XLS will be replaced by WTA01002.XLS)

B-2 : While pressing REC KEY twice, the data logger function will stop to execute, the record points will disappear on bottom right display as screen 2.

## screen 1 ( 5-6 B )

<b>V12:</b>	0.0 V	<b>V1:</b>	0.0 V	<b>A1:</b>	0.00 A
<b>V23:</b>	0.0 V	<b>V2:</b>	0.0 V	<b>A2:</b>	0.00 A
<b>V31:</b>	0.0 V	<b>V3:</b>	0.0 V	<b>A3:</b>	0.00 A
<b>P1:</b>	- 0.000 KW	<b>S1:</b>	0.000 KVA	<b>Q1:</b>	- 0.000 KVAR
<b>P2:</b>	- 0.000 KW	<b>S2:</b>	0.000 KVA	<b>Q2:</b>	- 0.000 KVAR
<b>P3:</b>	- 0.000 KW	<b>S3:</b>	0.000 KVA	<b>Q3:</b>	- 0.000 KVAR
<b>PΣ</b>	- 0.000 KW	<b>SΣ :</b>	0.000 KVA	<b>QΣ :</b>	- 0.000 KVAR
<b>PF1:</b>	- 0.00	<b>PF2:</b>	- 0.00	<b>PF3:</b>	- 0.00
<b>PFΣ :</b>	0.00	<b>PFH:</b>	0.00		
<b>Φ 1:</b>	- 0.0°	<b>Φ 2:</b>	- 0.0°	<b>Φ 3:</b>	- 0.0°
<b>WH:</b>	0.000 KWH	<b>SH:</b>	0.000 KVAH		
<b>QH:</b>	0.000 KVARH	<b>FREQ:</b>	0.0 Hz		
<b>AUTO</b>				<b>REC</b>	
<b>20A</b>	<b>3Φ 4W</b>	<b>SEC: 2</b>	<b>CT: 1</b>	<b>PT: 1</b>	<b>9</b>

## screen 2 ( 5-6 B )

<b>V12:</b>	0.0 V	<b>V1:</b>	0.0 V	<b>A1:</b>	0.00 A
<b>V23:</b>	0.0 V	<b>V2:</b>	0.0 V	<b>A2:</b>	0.00 A
<b>V31:</b>	0.0 V	<b>V3:</b>	0.0 V	<b>A3:</b>	0.00 A
<b>P1:</b>	- 0.000 KW	<b>S1:</b>	0.000 KVA	<b>Q1:</b>	- 0.000 KVAR
<b>P2:</b>	- 0.000 KW	<b>S2:</b>	0.000 KVA	<b>Q2:</b>	- 0.000 KVAR
<b>P3:</b>	- 0.000 KW	<b>S3:</b>	0.000 KVA	<b>Q3:</b>	- 0.000 KVAR
<b>PΣ</b>	- 0.000 KW	<b>SΣ :</b>	0.000 KVA	<b>QΣ :</b>	- 0.000 KVAR
<b>PF1:</b>	- 0.00	<b>PF2:</b>	- 0.00	<b>PF3:</b>	- 0.00
<b>PFΣ :</b>	0.00	<b>PFH:</b>	0.00		
<b>Φ 1:</b>	- 0.0°	<b>Φ 2:</b>	- 0.0°	<b>Φ 3:</b>	- 0.0°
<b>WH:</b>	0.000 KWH	<b>SH:</b>	0.000 KVAH		
<b>QH:</b>	0.000 KVARH	<b>FREQ:</b>	0.0 Hz		
<b>AUTO</b>				<b>REC</b>	
<b>20A</b>	<b>3Φ 4W</b>	<b>SEC: 2</b>	<b>CT: 1</b>	<b>PT: 1</b>	

### 5-8 Data HOLD Function

A: During the measurement, press HOLD KEY once, the bottom right display will show " HOLD symbol as screen 1.

B: Press the HOLD KEY twice will disable the Data HOLD function and the " HOLD" symbol will disappear in the meantime

screen 1 ( 5-7 )

<b>V12:</b> 0.0 V	<b>V1:</b> 0.0 V	<b>A1:</b> 0.00 A
<b>V23:</b> 0.0 V	<b>V2:</b> 0.0 V	<b>A2:</b> 0.00 A
<b>V31:</b> 0.0 V	<b>V3:</b> 0.0 V	<b>A3:</b> 0.00 A
<b>P1:</b> - 0.000 KW	<b>S1:</b> 0.000 KVA	<b>Q1:</b> - 0.000 KVAR
<b>P2:</b> - 0.000 KW	<b>S2:</b> 0.000 KVA	<b>Q2:</b> - 0.000 KVAR
<b>P3:</b> - 0.000 KW	<b>S3:</b> 0.000 KVA	<b>Q3:</b> - 0.000 KVAR
<b>PΣ</b> - 0.000 KW	<b>SΣ :</b> 0.000 KVA	<b>QΣ :</b> - 0.000 KVAR
<b>PF1:</b> - 0.00	<b>PF2:</b> - 0.00	<b>PF3:</b> - 0.00
<b>PFΣ :</b> 0.00	<b>PFH:</b> 0.00	
<b>Φ 1:</b> - 0.0°	<b>Φ 2:</b> - 0.0°	<b>Φ 3:</b> - 0.0°
<b>WH:</b> 0.000 KWH	<b>SH:</b> 0.000 KVAH	
<b>QH:</b> 0.000 KVARH	<b>FREQ:</b> 0.0 Hz	
<b>AUTO</b>		
<b>20A</b>	<b>3Φ4W</b>	<b>SEC: 2 CT: 1 PT: 1 HOLD</b> ←

screen 2 ( 5-7 )

<b>V12:</b> 0.0 V	<b>V1:</b> 0.0 V	<b>A1:</b> 0.00 A
<b>V23:</b> 0.0 V	<b>V2:</b> 0.0 V	<b>A2:</b> 0.00 A
<b>V31:</b> 0.0 V	<b>V3:</b> 0.0 V	<b>A3:</b> 0.00 A
<b>P1:</b> - 0.000 KW	<b>S1:</b> 0.000 KVA	<b>Q1:</b> - 0.000 KVAR
<b>P2:</b> - 0.000 KW	<b>S2:</b> 0.000 KVA	<b>Q2:</b> - 0.000 KVAR
<b>P3:</b> - 0.000 KW	<b>S3:</b> 0.000 KVA	<b>Q3:</b> - 0.000 KVAR
<b>PΣ</b> - 0.000 KW	<b>SΣ :</b> 0.000 KVA	<b>QΣ :</b> - 0.000 KVAR
<b>PF1:</b> - 0.00	<b>PF2:</b> - 0.00	<b>PF3:</b> - 0.00
<b>PFΣ :</b> 0.00	<b>PFH:</b> 0.00	
<b>Φ 1:</b> - 0.0°	<b>Φ 2:</b> - 0.0°	<b>Φ 3:</b> - 0.0°
<b>WH:</b> 0.000 KWH	<b>SH:</b> 0.000 KVAH	
<b>QH:</b> 0.000 KVARH	<b>FREQ:</b> 0.0 Hz	
<b>AUTO</b>		
<b>20A</b>	<b>3Φ4W</b>	<b>SEC: 2 CT: 1 PT: 1</b>



## 5-9 BACKLIGHT KEY

**Control the backlight function of LCD to ON/OFF**

## 5-10 A ( Current ) RANGE KEY function

**Change AUTO RANGE to MANUAL RANGE**

A : One by one to press A RANGE KEY will entry to different ranges as following screens in sequence. Range 200A (as show on bottom left display of screen 1) to 1200A (as screen 2) to 20A (as screen 3)

B : When hold A RANGE KEY down at least for 2 seconds will change MANUAL to AUTO as show on bottom left display of screen 4.

<b>V12:</b> 0.0 V	<b>V1:</b> 0.0 V	<b>A1:</b> 0.00 A
<b>V23:</b> 0.0 V	<b>V2:</b> 0.0 V	<b>A2:</b> 0.00 A
<b>V31:</b> 0.0 V	<b>V3:</b> 0.0 V	<b>A3:</b> 0.00 A
<b>P1:</b> - 0.000 KW	<b>S1:</b> 0.000 KVA	<b>Q1:</b> - 0.000 KVAR
<b>P2:</b> - 0.000 KW	<b>S2:</b> 0.000 KVA	<b>Q2:</b> - 0.000 KVAR
<b>P3:</b> - 0.000 KW	<b>S3:</b> 0.000 KVA	<b>Q3:</b> - 0.000 KVAR
<b>PΣ</b> - 0.000 KW	<b>SΣ :</b> 0.000 KVA	<b>QΣ :</b> - 0.000 KVAR
<b>PF1:</b> - 0.00	<b>PF2:</b> - 0.00	<b>PF3:</b> - 0.00
<b>PFΣ :</b> 0.00	<b>PFH:</b> 0.00	
<b>Φ 1:</b> - 0.0°	<b>Φ 2:</b> - 0.0°	<b>Φ 3:</b> - 0.0°
<b>WH:</b> 0.000 KWH	<b>SH:</b> 0.000 KVAH	
<b>QH:</b> 0.000 KVARH	<b>FREQ:</b> 0.0 Hz	
<b>MANU</b>		
<b>200A</b>	<b>3Φ4W</b>	<b>SEC: 2</b>
		<b>CT: 1</b>
		<b>PT: 1</b>

screen 1 ( 5-9 )

<b>V12:</b>	0.0 V	<b>V1:</b>	0.0 V	<b>A1:</b>	0.00 A
<b>V23:</b>	0.0 V	<b>V2:</b>	0.0 V	<b>A2:</b>	0.00 A
<b>V31:</b>	0.0 V	<b>V3:</b>	0.0 V	<b>A3:</b>	0.00 A
<b>P1:</b>	- 0.000 KW	<b>S1:</b>	0.000 KVA	<b>Q1:</b>	- 0.000 KVAR
<b>P2:</b>	- 0.000 KW	<b>S2:</b>	0.000 KVA	<b>Q2:</b>	- 0.000 KVAR
<b>P3:</b>	- 0.000 KW	<b>S3:</b>	0.000 KVA	<b>Q3:</b>	- 0.000 KVAR
<b>PΣ</b>	- 0.000 KW	<b>SΣ :</b>	0.000 KVA	<b>QΣ :</b>	- 0.000 KVAR
<b>PF1:</b>	- 0.00	<b>PF2:</b>	- 0.00	<b>PF3:</b>	- 0.00
<b>PFΣ :</b>	0.00	<b>PFH:</b>	0.00		
<b>Φ 1:</b>	- 0.0°	<b>Φ 2:</b>	- 0.0°	<b>Φ 3:</b>	- 0.0°
<b>WH:</b>	0.000 KWH	<b>SH:</b>	0.000 KVAH		
<b>QH:</b>	0.000 KVARH	<b>FREQ:</b>	0.0 Hz		
<b>MANU</b>					
<b>1200A</b>	<b>3Φ4W</b>	<b>SEC: 2</b>	<b>CT: 1</b>	<b>PT: 1</b>	

screen 2 ( 5-9 )

<b>V12:</b>	0.0 V	<b>V1:</b>	0.0 V	<b>A1:</b>	0.00 A
<b>V23:</b>	0.0 V	<b>V2:</b>	0.0 V	<b>A2:</b>	0.00 A
<b>V31:</b>	0.0 V	<b>V3:</b>	0.0 V	<b>A3:</b>	0.00 A
<b>P1:</b>	- 0.000 KW	<b>S1:</b>	0.000 KVA	<b>Q1:</b>	- 0.000 KVAR
<b>P2:</b>	- 0.000 KW	<b>S2:</b>	0.000 KVA	<b>Q2:</b>	- 0.000 KVAR
<b>P3:</b>	- 0.000 KW	<b>S3:</b>	0.000 KVA	<b>Q3:</b>	- 0.000 KVAR
<b>PΣ</b>	- 0.000 KW	<b>SΣ :</b>	0.000 KVA	<b>QΣ :</b>	- 0.000 KVAR
<b>PF1:</b>	- 0.00	<b>PF2:</b>	- 0.00	<b>PF3:</b>	- 0.00
<b>PFΣ :</b>	0.00	<b>PFH:</b>	0.00		
<b>Φ 1:</b>	- 0.0°	<b>Φ 2:</b>	- 0.0°	<b>Φ 3:</b>	- 0.0°
<b>WH:</b>	0.000 KWH	<b>SH:</b>	0.000 KVAH		
<b>QH:</b>	0.000 KVARH	<b>FREQ:</b>	0.0 Hz		
<b>MANU</b>					
<b>20A</b>	<b>3Φ4W</b>	<b>SEC: 2</b>	<b>CT: 1</b>	<b>PT: 1</b>	

screen 3 ( 5-9 )

<b>V12:</b>	0.0 V	<b>V1:</b>	0.0 V	<b>A1:</b>	0.00 A
<b>V23:</b>	0.0 V	<b>V2:</b>	0.0 V	<b>A2:</b>	0.00 A
<b>V31:</b>	0.0 V	<b>V3:</b>	0.0 V	<b>A3:</b>	0.00 A
<b>P1:</b>	- 0.000 KW	<b>S1:</b>	0.000 KVA	<b>Q1:</b>	- 0.000 KVAR
<b>P2:</b>	- 0.000 KW	<b>S2:</b>	0.000 KVA	<b>Q2:</b>	- 0.000 KVAR
<b>P3:</b>	- 0.000 KW	<b>S3:</b>	0.000 KVA	<b>Q3:</b>	- 0.000 KVAR
<b>PΣ</b>	- 0.000 KW	<b>SΣ :</b>	0.000 KVA	<b>QΣ :</b>	- 0.000 KVAR
<b>PF1:</b>	- 0.00	<b>PF2:</b>	- 0.00	<b>PF3:</b>	- 0.00
<b>PFΣ :</b>	0.00	<b>PFH:</b>	0.00		
<b>Φ 1:</b>	- 0.0°	<b>Φ 2:</b>	- 0.0°	<b>Φ 3:</b>	- 0.0°
<b>WH:</b>	0.000 KWH	<b>SH:</b>	0.000 KVAH		
<b>QH:</b>	0.000 KVARH	<b>FREQ:</b>	0.0 Hz		
<b>AUTO</b>					
<b>20A</b>	<b>3Φ4W</b>	<b>SEC: 2</b>	<b>CT: 1</b>	<b>PT: 1</b>	

screen 4 ( 5-9 )

**5-11 The LOWBAT screen: as show on lower right display of the following screen.**

<b>V12:</b>	0.0 V	<b>V1:</b>	0.0 V	<b>A1:</b>	0.00 A
<b>V23:</b>	0.0 V	<b>V2:</b>	0.0 V	<b>A2:</b>	0.00 A
<b>V31:</b>	0.0 V	<b>V3:</b>	0.0 V	<b>A3:</b>	0.00 A
<b>P1:</b>	- 0.000 KW	<b>S1:</b>	0.000 KVA	<b>Q1:</b>	- 0.000 KVAR
<b>P2:</b>	- 0.000 KW	<b>S2:</b>	0.000 KVA	<b>Q2:</b>	- 0.000 KVAR
<b>P3:</b>	- 0.000 KW	<b>S3:</b>	0.000 KVA	<b>Q3:</b>	- 0.000 KVAR
<b>PΣ</b>	- 0.000 KW	<b>SΣ :</b>	0.000 KVA	<b>QΣ :</b>	- 0.000 KVAR
<b>PF1:</b>	- 0.00	<b>PF2:</b>	- 0.00	<b>PF3:</b>	- 0.00
<b>PFΣ :</b>	0.00	<b>PFH:</b>	0.00		
<b>Φ 1:</b>	- 0.0°	<b>Φ 2:</b>	- 0.0°	<b>Φ 3:</b>	- 0.0°
<b>WH:</b>	0.000 KWH	<b>SH:</b>	0.000 KVAH		
<b>QH:</b>	0.000 KVARH	<b>FREQ:</b>	0.0 Hz		
<b>AUTO</b>				<b>LOWBAT</b>	
<b>20A</b>	<b>3Φ4W</b>	<b>SEC: 2</b>	<b>CT: 1</b>	<b>PT: 1</b>	

## **5-12 Appendix 1**

- \* V12, V23, V31 : Line Voltage
- \* V1, V2, V3 : Phase Voltage
- \* A1, A2, A3 : Line Current
- \* P1, P2, P3 : True Power of each phase. (W)
- \* S1, S2, S3 : Apparent Power of each phase. (VA)
- \* Q1, Q2, Q3 : Reactive Power of each phase (VAR)
- \*  $P\Sigma$  : Total True Power (W)
- \*  $S\Sigma$  : Total Apparent Power (VA)
- \*  $Q\Sigma$  : Total Reactive Power (VAR)
- \* PF1, PF2, PF3 : Power Factor of each phase
- \*  $PF\Sigma$  : Total Power Factor
- \* PFH : Long Term Average Power Factor ( WH/SH )
- \*  $\Phi 1, \Phi 2, \Phi 3$  : Phase Angle of each phase
- \* WH : Watt Hour
- \* SH : Apparent Power Hour
- \* QH : Reactive Power Hour
- \* 1 $\Phi$  2W : One phase by two wires
- \* 1 $\Phi$  3W : One phase by three wires
- \* 3 $\Phi$  3W : Three phases by three wires
- \* 3 $\Phi$  4W : Three phases by four wires
- \* SEC : The sampling time of data logger
- \* CT : Current transformer
- \* PT : Potential transformer

## 6. Maintenance

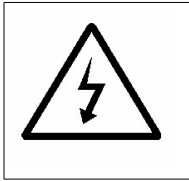

**Caution :** *Remove test leads before opening the battery cover or housing case !*

### **6-1 Cleaning**



**Caution :** *Cleaning - Only use the dry cloth to clean the plastic case !*

### **6-2 Replacement of batteries**

- 1) When Display show the " LOWBAT " indicator ( ref. 5-10 page 48 ), it should change the batteries.
- 2) open the " Battery Cover " ( 3-19, Fig. 1 ) away from the instrument and remove the battery.
- 3) Replace with batteries ( DC 1.5V, AA/UM-3 battery X 8 PCs ) and reinstate the cover.

**\* When install the batteries, should make attention the battery polarity.**

- 4) Make sure the battery cover is secured after changing the batteries.

## 7. RS232 Pc serial output

The instrument is provided an 3.5 mm dia. phone socket ( 3-16, Fig. 1 ) for RS232 computer interface socket.

The connector output is a 16 digits data stream which can be utilized to the user's specific application.

**A RS232 lead with the following connection will be required to link the instrument with the PC serial input.**

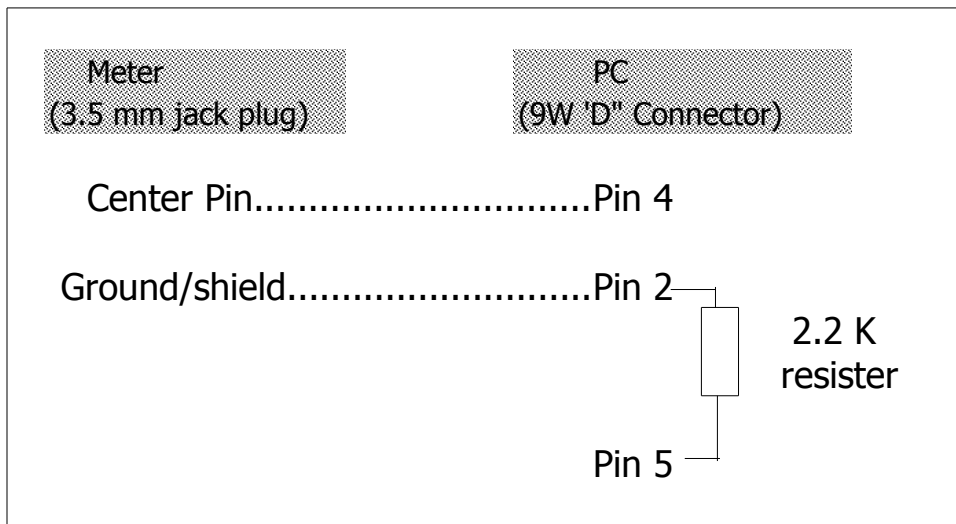

**The 16 digits data stream will be displayed in the following format :**

D15 D14 D13 D12 D11 D10 D9 D8 D7 D6 D5 D4 D3 D2 D1 D0

**Each digit indicate the following status :**

D15	Start Word
D14	4
D13	1
D12 & D11	Annunciator for Display
	31=HZ                      C0 = MW                      D1 = GW/Hr
	32=DEGREE                C1 = GW                      D2 = TW/Hr
	48=K WATT                C2 = TW                      D3 = KVA/Hr
	50=ACV                    C3 = MVA                    D4 = MVA/Hr
	52=ACA                    C4 = GVA                    D5 = GVA/Hr
	64=KVA                    C5 = TVA                    D6 = TVA/Hr
	65=KW/HR                C6 = KVAR                  D7 = KVAR/Hr
	B6 = KACV                C7 = MVAR                  D8 = MVAR/Hr
	B7 = MACV                C8 = GVAR                  D9 = GVAR/Hr
	B8 = KACA                C9 = TVAR                  E0 = TVAR/Hr
	B9 = MACA                D0 = MW/Hr
D10	Polarity 0 = Positive    1 = Negative
D9	Decimal Point(DP), position from right to the left 0 = No DP, 1= 1 DP, 2 = 2 DP, 3 = 3 DP
D8 to D1	Display reading, D1 = LSD, D8 = MSD For example : If the display reading is 1234, then D8 to D1 is : 00001234
D0	End Word

**RS232 setting**

Baud rate	9600
Parity	No parity
Data bit no.	8 Data bits
Stop bit	1 Stop bit

## 8. Download the saving data from the sd card to the computer (excel software)

- 1) After execute the Data Logger function, take away the SD card out from the " SD card socket " ( 3-15, Fig. 1 ).
- 2) Plug in the SD card into the Computer's SD card slot ( if your computer build in this installation ) or insert the SD card into the " SD card adapter ". then connect the " SD card adapter " into the computer.
- 3) Power ON the computer and run the " EXCEL software ".  
 Download the saving data file ( for example the file name : 3P401001.XLS, 1P201001.XLS, 1P301001.XLS, 3P301001.XLS.....) from the SD card to the computer. The saving data will present into the EXCEL software screen ( for example as following EXCEL data screens ) , then user can use those EXCEL data to make the further Data or Graphic analysis usefully.

EXCEL data screen 1 ( for example )

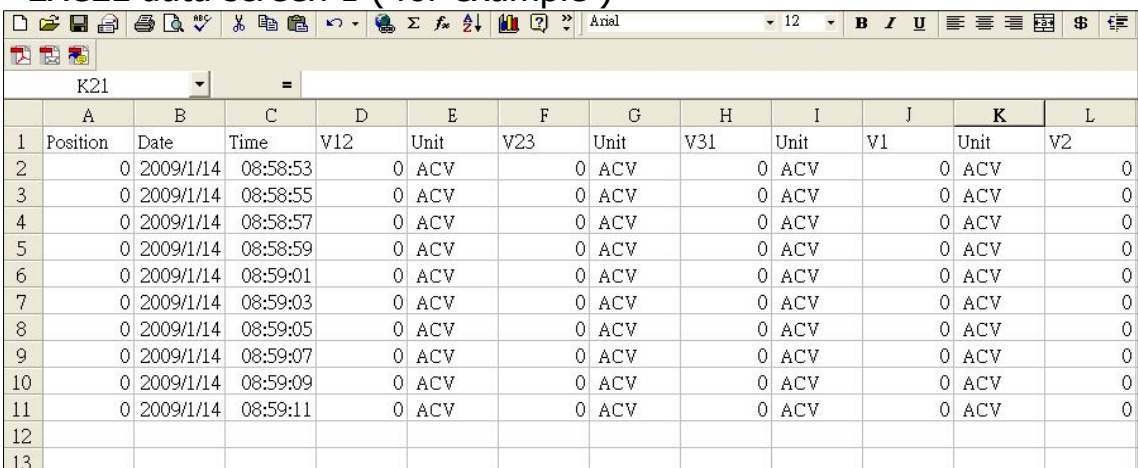

	A	B	C	D	E	F	G	H	I	J	K	L
1	Position	Date	Time	V12	Unit	V23	Unit	V31	Unit	V1	Unit	V2
2	0	2009/1/14	08:58:53	0	ACV	0	ACV	0	ACV	0	ACV	0
3	0	2009/1/14	08:58:55	0	ACV	0	ACV	0	ACV	0	ACV	0
4	0	2009/1/14	08:58:57	0	ACV	0	ACV	0	ACV	0	ACV	0
5	0	2009/1/14	08:58:59	0	ACV	0	ACV	0	ACV	0	ACV	0
6	0	2009/1/14	08:59:01	0	ACV	0	ACV	0	ACV	0	ACV	0
7	0	2009/1/14	08:59:03	0	ACV	0	ACV	0	ACV	0	ACV	0
8	0	2009/1/14	08:59:05	0	ACV	0	ACV	0	ACV	0	ACV	0
9	0	2009/1/14	08:59:07	0	ACV	0	ACV	0	ACV	0	ACV	0
10	0	2009/1/14	08:59:09	0	ACV	0	ACV	0	ACV	0	ACV	0
11	0	2009/1/14	08:59:11	0	ACV	0	ACV	0	ACV	0	ACV	0
12												
13												



## EXCEL data screen 2 ( for example )

	N	O	P	Q	R	S	T	U	V	W	X	Y
1	V3	Unit	A1	Unit	A2	Unit	A3	Unit	P1	Unit	P2	Unit
2		0 ACV	0	0 ACA	0	0 ACA	0	0 ACA	0	0 KW	0	0 KW
3		0 ACV	0	0 ACA	0	0 ACA	0	0 ACA	0	0 KW	0	0 KW
4		0 ACV	0	0 ACA	0	0 ACA	0	0 ACA	0	0 KW	0	0 KW
5		0 ACV	0	0 ACA	0	0 ACA	0	0 ACA	0	0 KW	0	0 KW
6		0 ACV	0	0 ACA	0	0 ACA	0	0 ACA	0	0 KW	0	0 KW
7		0 ACV	0	0 ACA	0	0 ACA	0	0 ACA	0	0 KW	0	0 KW
8		0 ACV	0	0 ACA	0	0 ACA	0	0 ACA	0	0 KW	0	0 KW
9		0 ACV	0	0 ACA	0	0 ACA	0	0 ACA	0	0 KW	0	0 KW
10		0 ACV	0	0 ACA	0	0 ACA	0	0 ACA	0	0 KW	0	0 KW
11		0 ACV	0	0 ACA	0	0 ACA	0	0 ACA	0	0 KW	0	0 KW
12												
13												

## EXCEL data screen 3 ( for example )

	AA	AB	AC	AD	AE	AF	AG	AH	AI	AJ	AK	
1	P3	Unit	P(SUM)	Unit	S1	Unit	S2	Unit	S3	Unit	S(SUM)	Unit
2		0 KW	0	0 KW	0	0 KVA	0	0 KVA	0	0 KVA	0	0 KVA
3		0 KW	0	0 KW	0	0 KVA	0	0 KVA	0	0 KVA	0	0 KVA
4		0 KW	0	0 KW	0	0 KVA	0	0 KVA	0	0 KVA	0	0 KVA
5		0 KW	0	0 KW	0	0 KVA	0	0 KVA	0	0 KVA	0	0 KVA
6		0 KW	0	0 KW	0	0 KVA	0	0 KVA	0	0 KVA	0	0 KVA
7		0 KW	0	0 KW	0	0 KVA	0	0 KVA	0	0 KVA	0	0 KVA
8		0 KW	0	0 KW	0	0 KVA	0	0 KVA	0	0 KVA	0	0 KVA
9		0 KW	0	0 KW	0	0 KVA	0	0 KVA	0	0 KVA	0	0 KVA
10		0 KW	0	0 KW	0	0 KVA	0	0 KVA	0	0 KVA	0	0 KVA
11		0 KW	0	0 KW	0	0 KVA	0	0 KVA	0	0 KVA	0	0 KVA
12												
13												

## EXCEL data screen 4 ( for example )

	AL	AM	AN	AO	AP	AQ	AR	AS	AT	AU	AV	AW
1	Q1	Unit	Q2	Unit	Q3	Unit	Q(SUM)	Unit	PF1	Unit	PF2	Unit
2		0 KVAR	0	0 KVAR	0	0 KVAR	0	0 KVAR	0		0	
3		0 KVAR	0	0 KVAR	0	0 KVAR	0	0 KVAR	0		0	
4		0 KVAR	0	0 KVAR	0	0 KVAR	0	0 KVAR	0		0	
5		0 KVAR	0	0 KVAR	0	0 KVAR	0	0 KVAR	0		0	
6		0 KVAR	0	0 KVAR	0	0 KVAR	0	0 KVAR	0		0	
7		0 KVAR	0	0 KVAR	0	0 KVAR	0	0 KVAR	0		0	
8		0 KVAR	0	0 KVAR	0	0 KVAR	0	0 KVAR	0		0	
9		0 KVAR	0	0 KVAR	0	0 KVAR	0	0 KVAR	0		0	
10		0 KVAR	0	0 KVAR	0	0 KVAR	0	0 KVAR	0		0	
11		0 KVAR	0	0 KVAR	0	0 KVAR	0	0 KVAR	0		0	
12												
13												

### EXCEL data screen 5 ( for example )

	AX	AY	AZ	BA	BB	BC	BD	BE	BF	BG	BH	BI
1	PF3	Unit	PF(SUM)	Unit	PFH	Unit	PHASE1	Unit	PHASE2	Unit	PHASE3	Unit
2	0		0		0		0	Degree	0	Degree	0	Degree
3	0		0		0		0	Degree	0	Degree	0	Degree
4	0		0		0		0	Degree	0	Degree	0	Degree
5	0		0		0		0	Degree	0	Degree	0	Degree
6	0		0		0		0	Degree	0	Degree	0	Degree
7	0		0		0		0	Degree	0	Degree	0	Degree
8	0		0		0		0	Degree	0	Degree	0	Degree
9	0		0		0		0	Degree	0	Degree	0	Degree
10	0		0		0		0	Degree	0	Degree	0	Degree
11	0		0		0		0	Degree	0	Degree	0	Degree
12												
13												

### EXCEL data screen 6 ( for example )

	BJ	BK	BL	BM	BN	BO	BP	BQ	BR	BS	BT	BU
1	WH	Unit	SH	Unit	QH	Unit	FREQ	Unit				
2	0	KWH	0	KVAH	0	KVARH	0	Hz				
3	0	KWH	0	KVAH	0	KVARH	0	Hz				
4	0	KWH	0	KVAH	0	KVARH	0	Hz				
5	0	KWH	0	KVAH	0	KVARH	0	Hz				
6	0	KWH	0	KVAH	0	KVARH	0	Hz				
7	0	KWH	0	KVAH	0	KVARH	0	Hz				
8	0	KWH	0	KVAH	0	KVARH	0	Hz				
9	0	KWH	0	KVAH	0	KVARH	0	Hz				
10	0	KWH	0	KVAH	0	KVARH	0	Hz				
11	0	KWH	0	KVAH	0	KVARH	0	Hz				
12												
13												

### EXCEL graphic screen 1 ( for example )

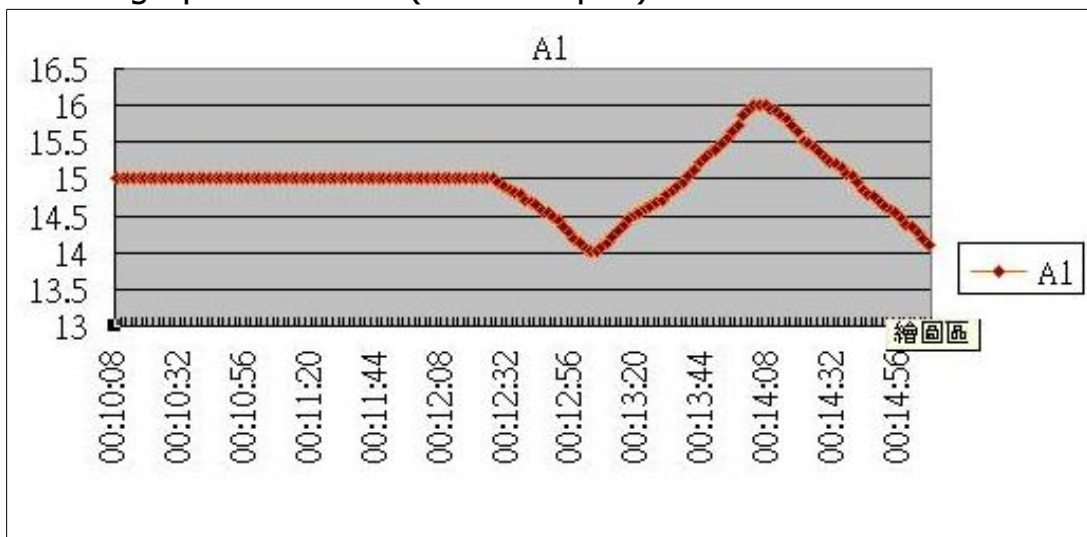

EXCEL graphic screen 2 ( for example )

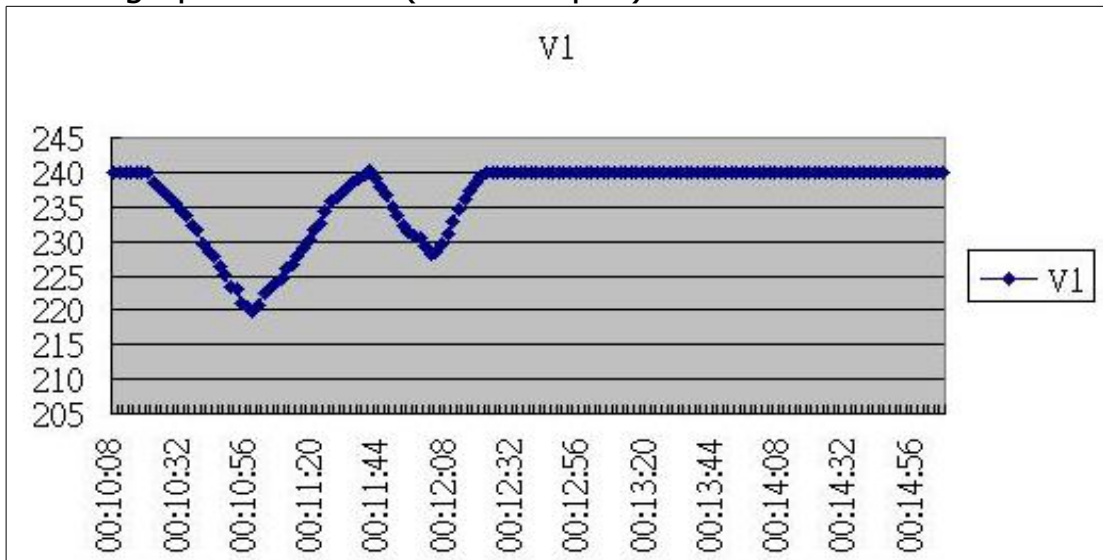

EXCEL graphic screen 3 ( for example )

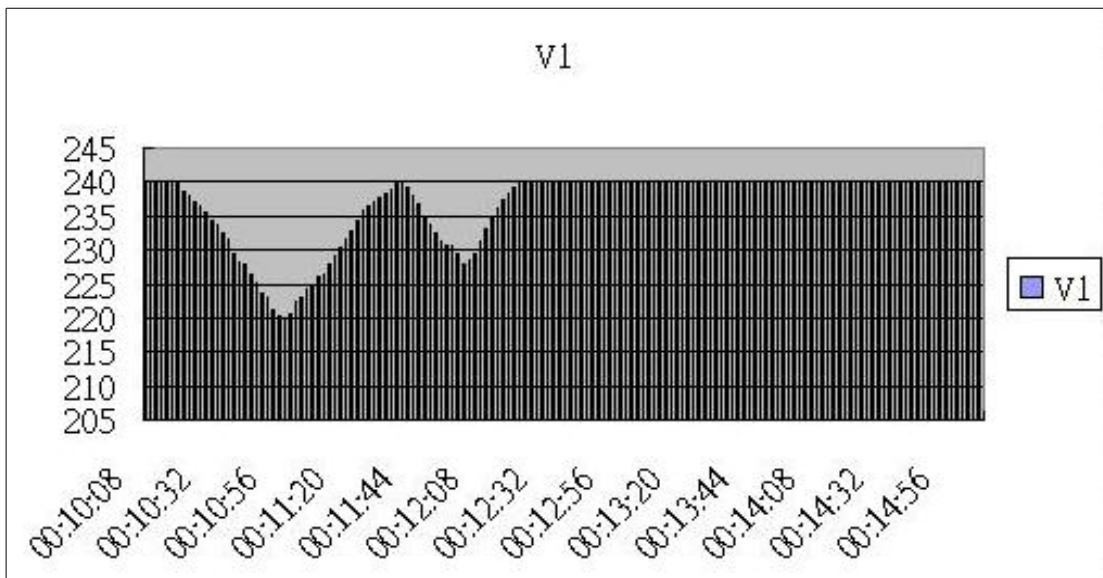

EXCEL graphic screen 4 ( for example )

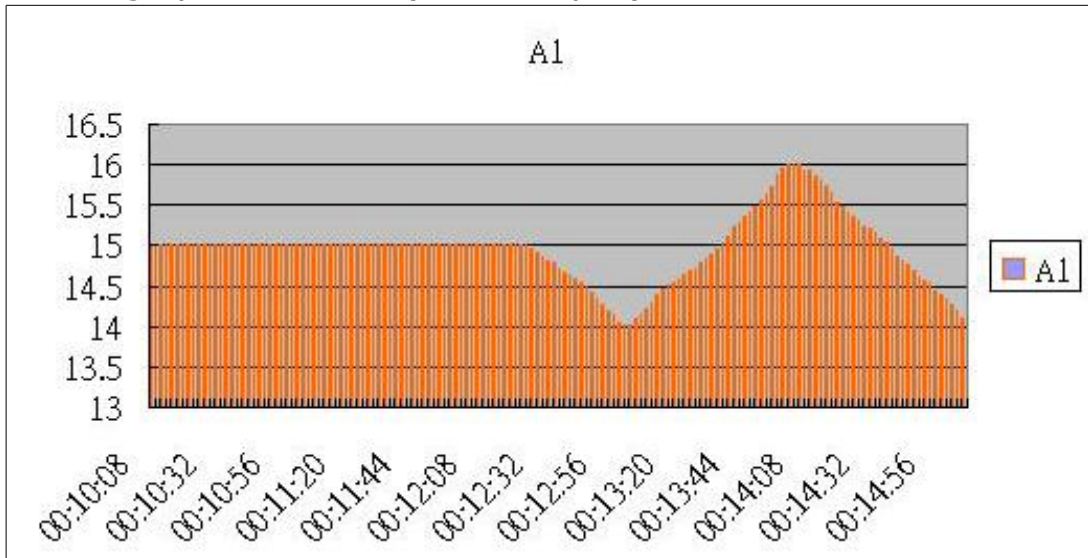

EXCEL graphic screen 5 ( for example )

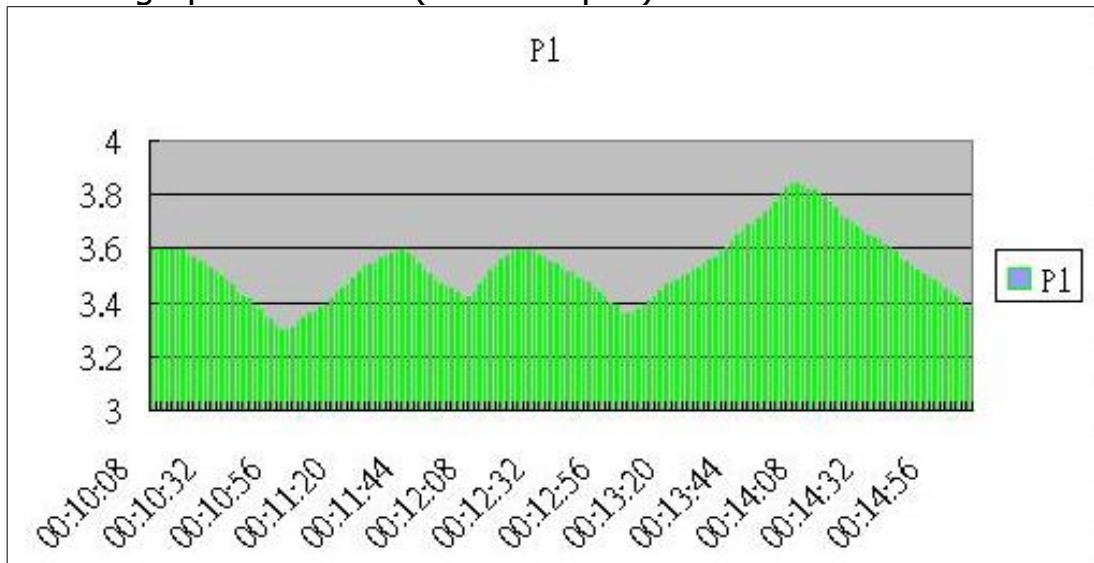

## 9. Patent

**The SD card installation for handheld instruments and the SD card data format structure ( Data to EXCEL file format ) already patent pending in the following countries :**

**U.S.A, CHINA, GERMANY, JAPAN, TAIWAN**

In this direction will find a vision of the measurement technique:  
<http://www.industrial-needs.com/measuring-instruments.htm>

**NOTE:** "This instrument doesn't have ATEX protection, so it should not be used in potentially explosive atmospheres (powder, flammable gases)."