



Tursdale Technical Services Ltd
Unit N12B
Tursdale Business Park
Co. Durham
DH6 5PG
United Kingdom
Phone: +44 (0) 191 377 3398
Fax: +44 (0) 191 377 3357
info@tursdaletechnicalservices.co.uk
<http://www.industrial-needs.com/>

Manual PCE TP 1500B/3000B



1. General description.....	3
2. Completion	4
3. Technical data	4
4. Safety principles	5
5. Principles of used balance treatment.....	5
6. Balance keys and indicators	6
7. Balance preparation to work	7
8. Balance start.....	8
9. Operation principles.....	8
10. Balance test.....	9
11. Balance adjustment	9
12. Connection with computer or printer (option).....	9
13. Balance special functions description	12
13. Common weighing	13
14. Weighing with tare	13
15. Balance resolution increasing.....	14
16. Automatic zeroing function (F..-AUt).....	14
17. Pieces counting function (F..-PCS).....	15
18. Setting printer cooperation mode function (F..-LPt)	16
19. Serial port parameters setting function (F..-rS).....	17
20. Tare entering function (F..-tAr)	18
21. Menu update (F..-ACt)	19
22. Maintenance and small repairs.....	20
<i>Declaration of Conformity</i>	21

1. General description

Drive-through series in basic version from lacquered steel, with SE-01/A/18 meter, are designed for operation in light environmental conditions.

Manual describes standard balance version. In case of special meter use, e.g. dosing meter, it is necessary to use documentation for meter as well.

All balances are tested in respect of metrology. According to order, balances may be verified or calibrated.

EC verification (conformity assessment) of balances is required for special applications, mentioned in Ministry of Labour and Social Policy decree from 11.12.2003 (trade, tariffs, pharmacy recipes, medical and pharmaceutical analysis, packing of goods). For other applications it is recommended to replace verification with calibration.

Verified balances have the following verification features:

- protection stamps, located on balance meter and converters connection box (installed under the bearing surface).
- Office of Measures marks and green metrological mark, located on the rating plate.

EC verification is valid for 25 months from 1st of December of year, when the EC verification took place, under condition of stamp integrity.

Balances classification (PKWiU code) 29.24.23.
Certificates:



Certificate
of type approval
no. PL 04 020



Certificate
DIN EN ISO 9001:2000
no. 78 100 6386

2. Completion

Basic set includes:

1. Bearing surface,
- 2 drive-throughs and balance meter, connected permanently with cable
2. 4 locks
3. RS232C connector
4. Instruction manual
5. Warranty

3. Technical data

Balance type	PCE-TP 1500B	PCE-TP 3000B
Maximum load (Max)	1500kg	3000kg
Reading graduation (d)	0,5kg	1kg
Verification graduation (e)	0,5kg	1kg
Minimum load (Min)	10kg	20kg
Tare set range	-1500kg	-3000kg
Precision class	III	
Operational temperature	-10÷40°C	
Weighing time	<4s	
Skid dimensions (WxLxH)	120×1260×75mm	180×1260×105mm
Skid to skid cable length	5m	
Display to skid cable length	5m	
Power supply	~230V, 50Hz, 8VA	
Balance weight	40kg	
Meter protection rating	IP 54	

4. Safety principles

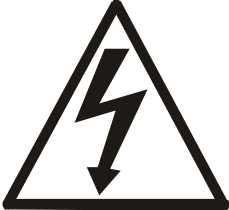
	<p>It is necessary to become familiar with safety principles shown below, which are necessary to avoid electric shock and damage of balance or connected devices.</p>
<ul style="list-style-type: none"> <input type="checkbox"/> Repairs and necessary adjustments must be performed by qualified personnel only. <input type="checkbox"/> To avoid fire hazard, use only typical supply cable, and supply voltage must be consistent with technical data. <input type="checkbox"/> For the balance supply use the socket with protective contact. <input type="checkbox"/> Do not use balance when the cover is removed. <input type="checkbox"/> Do not use balance in explosive atmosphere. <input type="checkbox"/> Do not use balance in locations with high humidity, when the cover does not have special protections (NAN types). <input type="checkbox"/> In case of damage suspicion, switch the balance off and do not use it until it is tested in professional service company. 	

5. Principles of used balance treatment

	<p>According to valid regulations regarding natural environment protection do not place used electronic devices in containers with common waste.</p>
<ul style="list-style-type: none"> <input type="checkbox"/> Used balance after operation period may be transferred to units authorized for collection of used electronic equipment, or to place of purchase. 	

6. Balance keys and indicators

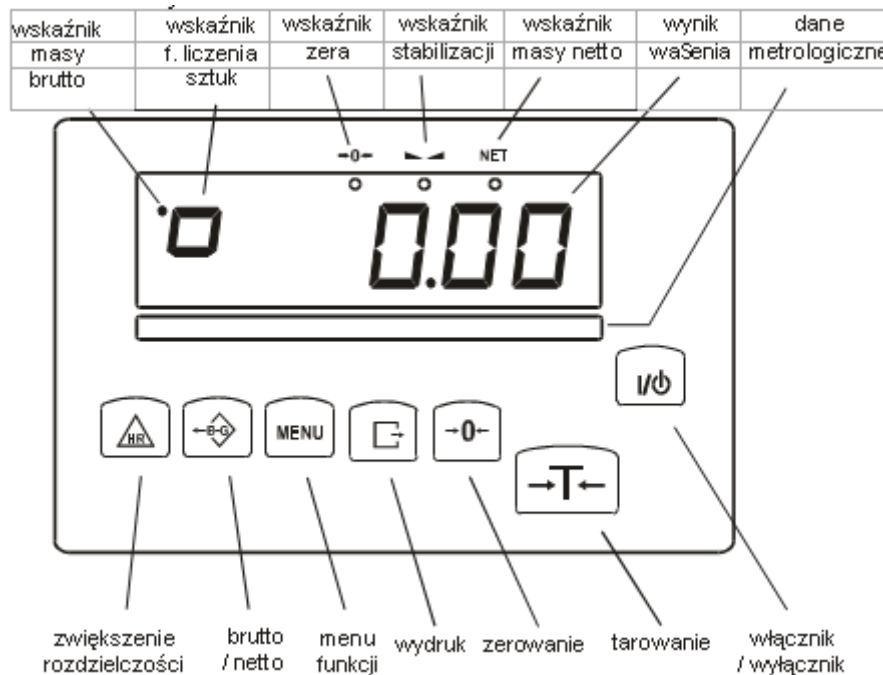

key		- ON/OFF switch (standby),
key		- tare setting (entering of mass subtracted from weighed mass),
key		- gross weight indication,
key		- zeroing,
key	MENU	- special functions menu,
key		- result print,
key		- weight indication resolution increasing,
indicator		- zero indicator (for unloaded balance),
indicator		- signals weighing result stabilization,
indicator	NET	- net weight (after key use),
indicator		- gross weight (after B/G key use),
indicator		- pieces counting function indicator (indications in pieces)

Additionally in LCD display version:

indicator	MODE-	- special function activation menu,
indicator	bar	- balance load indicator (0-100%),
indicator	WYŁ	- balance switched off with key (standby),
indicator	B/G	- gross weight (after B/G key use),
indicator	pcs	- indications in pieces

7. Balance preparation to work

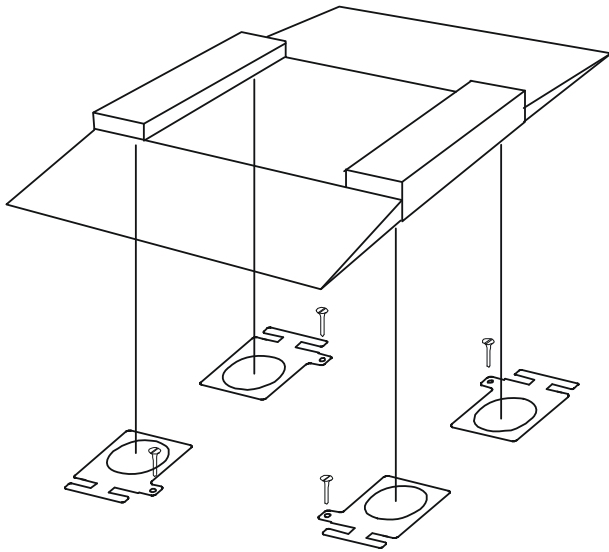

1. Unpack balance, removing protective foils.

2. Place balance on flat, horizontal foundation, in place not subjected to mechanical vibrations and strong air movements. Take care if the scale stays on all four legs.



Good

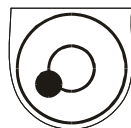

Bad

3. Air bubble in level should be located in the middle position.

4. Lift scale corners up and put locks under in such a way that scale legs go into prepared holes.

5. Mount locks permanently to the ground using $\varnothing 10$ holes.

6. Put balance approaches on settling them into locks.

7. Unscrew transport handles (mounted for transport).

8. Connect the supply cable plug to socket with protective contact, when balance is unloaded.

9. In hermetic scales clog unused connectors with additional caps.

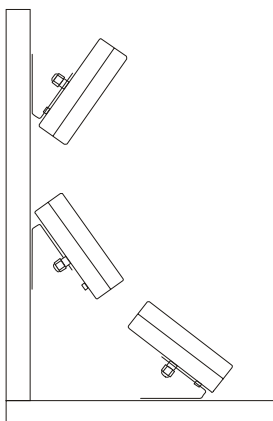

8. Balance start

Connecting of supply plug to socket of ~230V/50Hz installation with unloaded balance will cause the following sequence of actions:

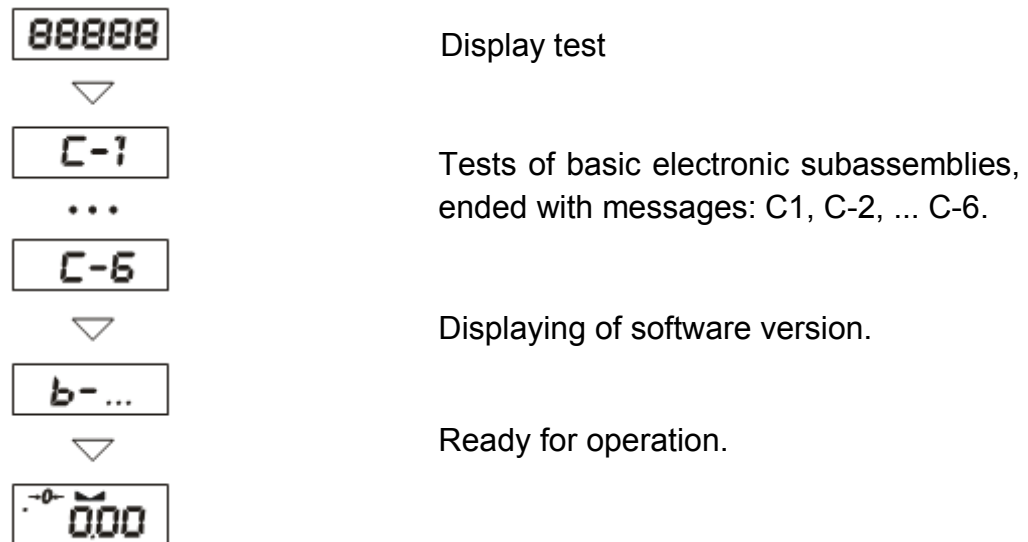

9. Operation principles



1. Before each measurement the balance should be properly zeroed, which is signalled by "0" indicator. If the zero indication is not shown when the balance is unloaded, or "----" is displayed, press the "0" key.
2. The balance enables tare setting in the whole measuring range. It is performed by pressing "T" key.
3. Weighed mass should be placed in the platform centre.



Do not drop weighed objects on the platform.



Do not overload the balance over 20% of maximum load.

4. The weighing result should be read during the "┌" indicator lighting, which indicates the result stabilization.
5. When there is no weighing, but the balance should be ready for operation, it may be switched off by I/  key. It causes the balance reading system deactivation end entering the standby mode. Balance turning on is performed by pressing "I/" key.
6. Protect the balance from dust, aggressive dusts and liquids. For cleaning purposes use water and dry it.

10. Balance test

During balance operation, in order to confirm its efficiency, it is recommended to check the weighing precision by putting an object of exactly known weight before and after a series of measurements.

For testing of verified balances use weight standard, having valid standardization certificates. In case of allowable measurement error exceeding contact authorized service company to perform balance adjustment.

11. Balance adjustment



Balance adjustment must be performed by authorized service company only, as it is connected with necessity of seals breaching, required for warranty purposes.

12. Connection with computer or printer (option)

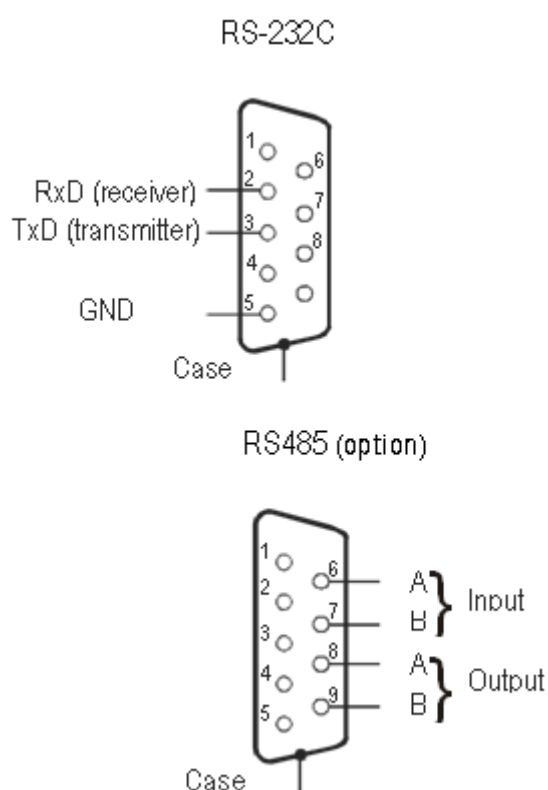

For data transfer to external devices the balance is equipped with RS232C or RS485 (option) connector.

balance sends the weighing result after the initiating signal from the computer, or pressing  key.

During the operation with printer data are sent automatically after sampling and reading stabilization, and the next transmission is possible after the sample removing. Sent results: successive measurement number and weighing result (see Printer cooperation mode).

In special version balance may be equipped with second connector, e.g. performing continuous transmission of current results to the additional display. To cooperate with balance, the computer must have the program, enabling the balance data processing. Such programs are included in balance producer's offer.

Detailed description of data transmission protocol for operation with computer:

Transmission parameters: 8 bits, 1 stop bit, no parity, baud rate 4800bps,

Data exchange method:

Balance indication reading (corresponds to  key use):

Computer \square Balance: S I CR LF (53h 49h 0Dh 0Ah) – initiation signal. Balance \square Computer: balance sends 16 bytes of data according to description:

Byte	1	- sign “-” or space
Byte	2	- space
Byte	3 \square 4	- digit or space
Byte	5 \div 9	- digit, comma or space
Byte	10	- digit
Byte	11	- space
Byte	12	- k, l, c, p or space
Byte	13	- g, b, t, c or %
Byte	14	- space
Byte	15	- CR
Byte	16	- LF

Tare setting from computer (corresponds to \square T \square key use):

Computer \square Balance: S T CR LF (53h 54h 0Dh 0Ah),

Balance \square Computer: no reply.

Balance zeroing (corresponds to \square 0 \square key use):

Computer \square Balance: S Z CR LF (53h 5Ah 0Dh 0Ah),

Balance \square Computer: no reply.

Balance switching on/off (corresponds to I/ ϕ key use):

Computer \square Balance: S S CR LF (53h 53h 0Dh 0Ah),

Balance □ Computer: no reply.
 Menu displaying (corresponds to MENU key use):
 Computer □ Balance: S F CR LF (53h 46h 0Dh 0Ah),
 Balance □ Computer: no reply.
 Setting of threshold 1 value (option):
 Computer □ Balance: S L D1...DN CR LF (53h 4Ch D1...DN 0Dh 0Ah) where: D1...DN – threshold value, maximum 8 characters.
 Balance □ Computer: no reply.

Example:

To set 1000g in balance B1.5 (d=0.5g) enter:
 S L 1 0 0 0 . 0 CR LF (53h 4Ch 31h 30h 30h 2Eh 30h 0Dh 0Ah). To set
 100kg in balance B150 (d=50g) enter:
 S L 1 0 0 . 0 0 CR LF (53h 4Ch 31h 30h 30h 2Eh 30h 30h 0Dh 0Ah),

Setting of threshold 2 value (option):
 Computer □ Balance: S H D1...DN CR LF (53h 48h D1...DN 0Dh 0Ah), where:
 D1...DN – threshold value, maximum 8 characters.
 Balance □ Computer: no reply.

Example:
 To set 1000g in balance B1.5 (d=0.5g) enter:
 S L 1 0 0 0 . 0 CR LF (53h 4Ch 31h 30h 30h 2Eh 30h 0Dh 0Ah). To set
 100kg in balance B150 (d=50g) enter:
 S L 1 0 0 . 0 0 CR LF (53h 4Ch 31h 30h 30h 2Eh 30h 30h 0Dh 0Ah),

Setting of threshold 2 value (option):
 Computer □ Balance: S H D1...DN CR LF (53h 48h D1...DN 0Dh 0Ah), where:
 D1...DN – threshold value, maximum 8 characters.
 Balance □ Computer: no reply.

Caution:

Entering of balance network number (F..rS / nr) different from zero changes balance operation method: computer communication with balance is possible after logging with command: 02h balance_no., logging out requires 03h command.

Connection cable WK-1 (RS232C connector) (connects balance with computer):

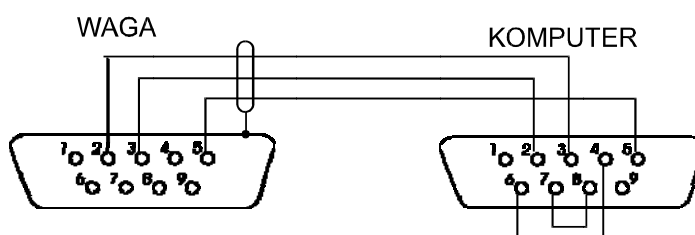

Setting of internal KAFKA printer switches:

SW-1	SW-2	SW-3	SW-4	SW-5	SW-6	SW-7	SW-8
on	off	on	off	off	on	off	off

13. Balance special functions description

All balances, besides the basic metrological functions: weighing and tare setting, have a set of user special functions.

Basic set of user functions includes:

- Automatic zeroing function (AUt)
- pieces counting (PCS),
- entering tare (tAr),
- set of work mode for serial port (LPt)
- set of work mode for serial port (rS)
- menu update (ACt)

Other functions may be available as options for demand (description of all user functions is presented in the separate document).

After pressing Menu button, start menu will be displayed. The functions are displayed with the successive numbers: F1-PCS, F2-AUt, ect.







User may change the menu content by activating or deactivating the available special functions with the Menu update function (ACt).

During the special functions switching the display shows the MODE indicator.

The functions operation are described with the drawings, showing the successive situations during the balance operation. On the drawings the “hand” indicates key, which should be pressed in the given situation.

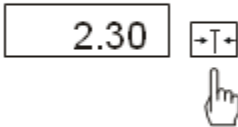
Meaning of drawing symbols:

-  - load on the pan
-  - load removed
-  - press the button during displaying this indication
-  - forced change
-  - automatic change

13. Common weighing

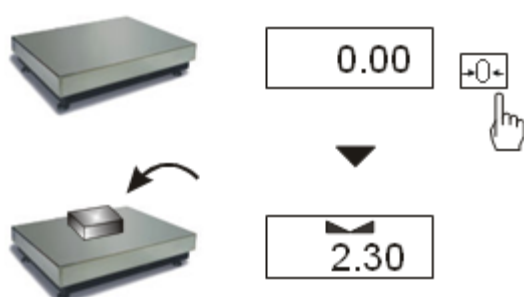

The 0 key operates only with unloaded pan, and zeroes the balance indication.

Weighing results should be read with the "↕" indicator on.

14. Weighing with tare



The balance enables tare setting in the whole measuring range.

The B/G button allows for reading gross weight.

Caution:
Repressing the B/G button switches to the net weight display.

15. Balance resolution increasing

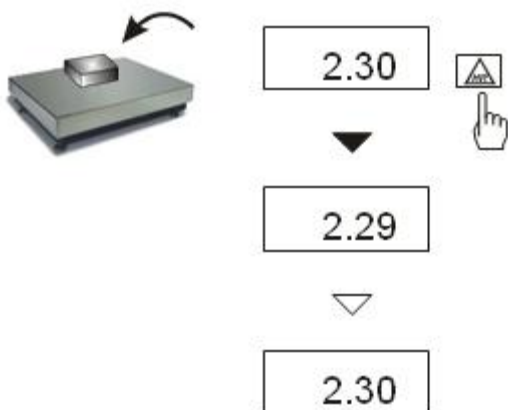

The HR button causes the momentary result displaying (approx. 5 secs) with the maximum resolution, allowed by the balance processor. That button is especially useful in the legalized balances with d=e reading graduation. The increased resolution result is the auxiliary information, and may not be printed or sent to the computer with the button.

16. Automatic zeroing function (F..-AUt)

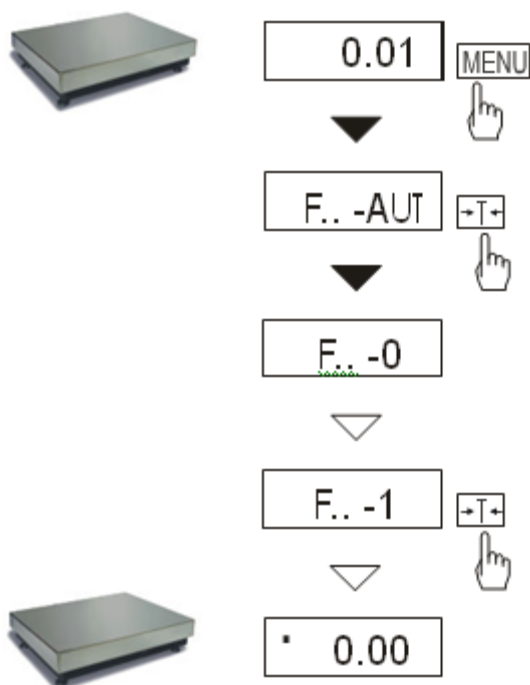

Function activation will cause automatic maintaining of zero indications, when the balance is not loaded, or when zero reading has been achieved by pressing "□T□" key. To finish the function operation press MENU key, then, using □T□ key, select F..-AUT and F..-0..

Caution:
For 10 minutes after switching on the balance, this function operates automatically.

17. Pieces counting function (F..-PCS)

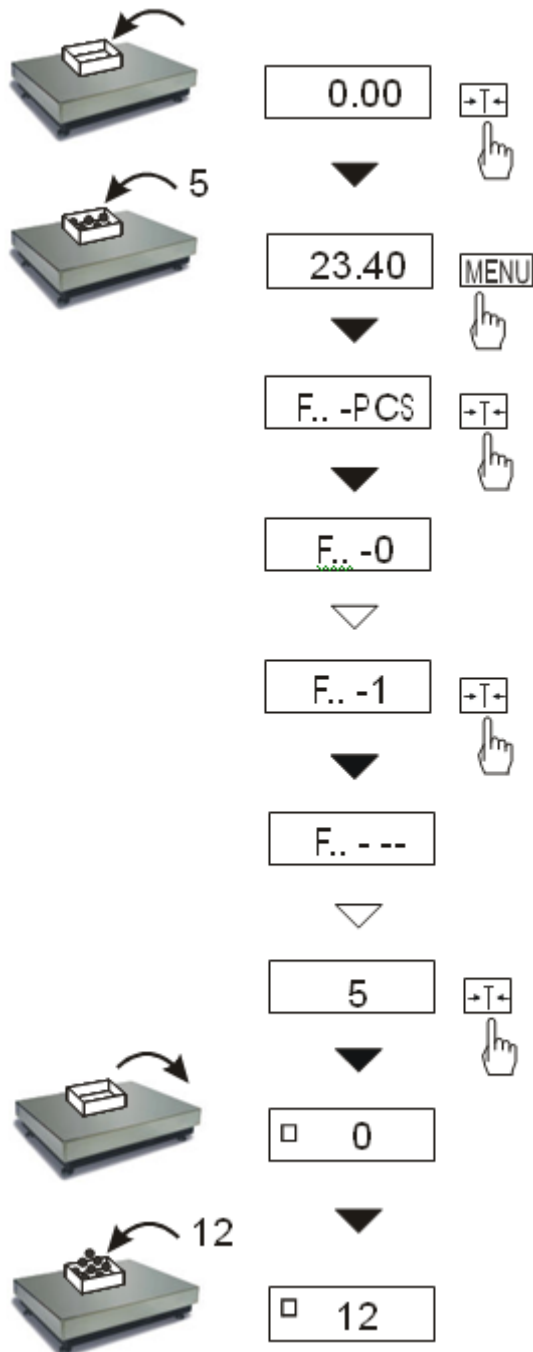

That function allows for counting the identical details, e.g. screws or nails, contained in the weighed batch.

The measurement takes place in two phases:

- first phase – calculation of single detail weight upon the basis of sample of specified number of pieces 5, 10, 20, 50, 100, 200, or 500 details,
- second phase – counting the details in the weighed batch.

It is recommended, that the single detail weight is higher than the balance reading graduation, and the weight of sample, used in the first phase is higher than 100 of reading graduations.

To finish the function operation press MENU button, then, using $\square T \square$ button, select F..-PCS and F..-0.

Notes:

The "Err-3" message means, that no sample is put on the balance.

The same message is displayed, when the single detail weight is lower than one reading graduation (user may calculate the pieces, keeping in mind, that it increases the error).

2. Selecting " _ _ " instead of details number in the sample recalls the previously entered value (that value must be entered, otherwise the error message will be displayed).

3. During that function the $\square T \square$ operates normally.

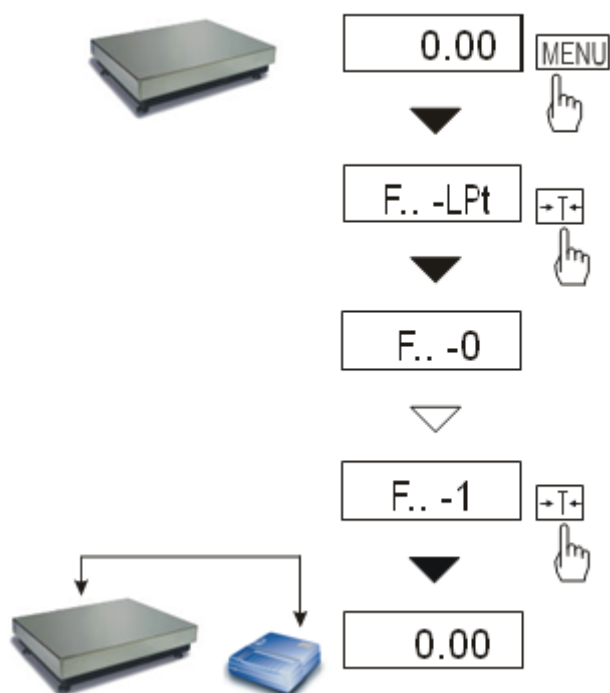

4. In the LCD display balances the " " sign is replaced by "pcs".

18. Setting printer cooperation mode function (F..-LPt)



This function sets the balance interface for the cooperation with printer. After its activation the measurement number and result

is printed automatically after putting and removing the  sample, without pressing key.

To enter the computer cooperation mode (key  activation and results transmission without numbering), press MENU key, then, using  key, select F..-LPt and F..-0.

19. Serial port parameters setting function (F..rS)

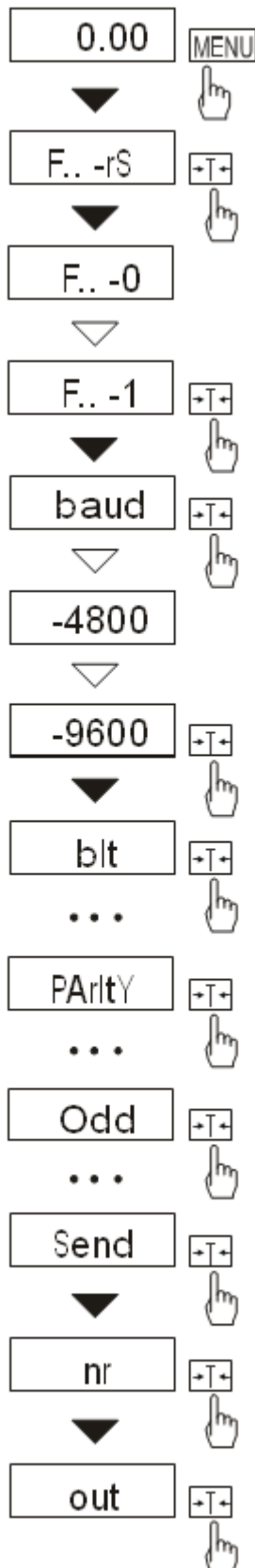

Function is available in balances equipped with serial port, e.g. RS232C, and allows for setting the following serial port transmission parameters:

- baud rate (bAud: 1200, 4800, 9600),
- bits in byte number (bit: 7, 8),
- parity control (PARitY: 0, 1; Odd: 0, 1),
- balance no. during connecting few balances to one computer (when the balance does not operate in multistation network, enter 0),
- continuous transmission – without using  key, approx. 10 results per second (SEnd: 0, 1).

Standard parameters are underlined.

In order to set the required parameters activate F..-Rs function, select the proper parameter and press  key during displaying of required parameter or option value. On the adjacent diagram setting of transmission rate of 9600 bps is shown. After setting of appropriate parameters and options exit by selecting out.

20. Tare entering function (F..-tAr)

This function allows for measurement of product gross weight in the container with known weight, and reading of calculated net weight. To do this, first enter the tare value to the balance memory. Entered tare value may be recalled by pressing

□0□ key, when balance is unloaded. Tare value entering may be performed using balance keys or “from nature”, when it is possible to place empty container on the balance.

Tare value entering:

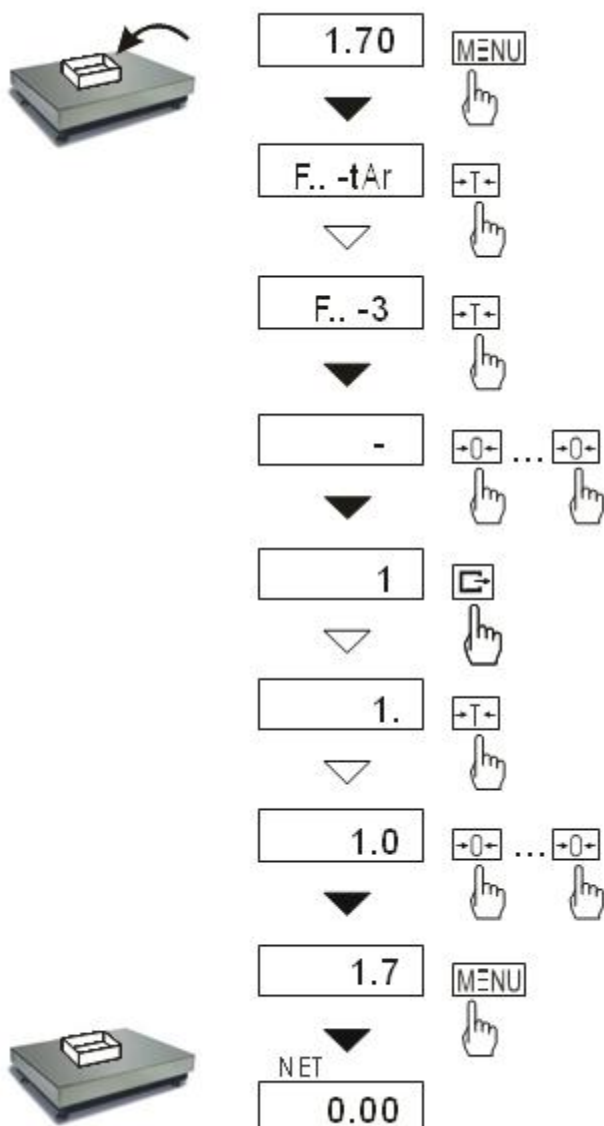

After function selection the following options are displayed:

- F-0 – function deactivation,
- F-1 function activation with previously entered tare,
- F-2 – entering of weight on the balance as tare,
- F-3 – entering tare value using keys: 0, T, MENU and

NET indicator.

F-1 and F-0 options allow for temporary deactivation and reactivation of function with previously entered tare value.

CAUTION

Tare value is stored in balance memory also after switching off.

Measurement with entered tare recalling:

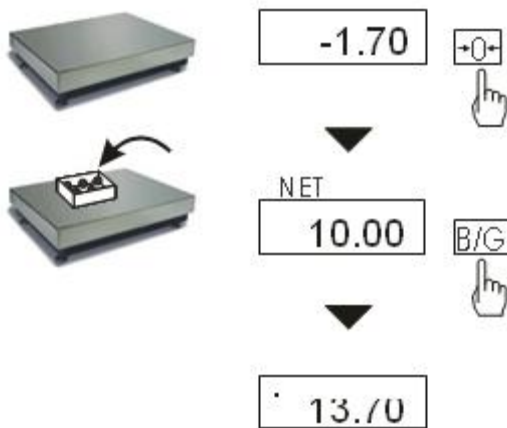

During measurement with activated function tAr use of $\square 0 \square$ causes balance zeroing with simultaneous recalling of tare value from balance memory. This value is displayed with sign “-”.

B/G key allows for switching to gross weight indications. Reprising the B/G key switches to net weight display

Caution:

$\square T \square$ key does not work with unloaded balance, use $\square 0 \square$ to recall tare.

21. Menu update (F..-ACt)

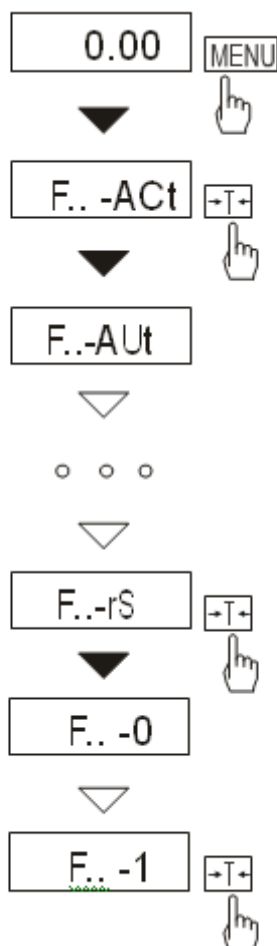

Among available user functions it is possible to select those, which will be displayed just after pressing MENU key. It allows for avoiding displaying of the whole list of available functions, which unnecessarily prolongs operation time.

On the adjacent diagrams there are actions for adding of exemplary function of setting of RS232C connector parameters (F..-rS) to functions menu.

To remove function from menu in last operation select F..-0 instead of F..-1.

22. Maintenance and small repairs

1. Keep the balance clean.
2. Take care, for during the operation some impurities may enter under balance base and into sensors vicinity. In case of impurities finding remove them.
3. In case of improper operation due to short power failure, switch off the balance by unplugging the power cable from the socket, and plug it again after a few seconds.
4. The message “Err-b”, displayed after switching on the unloaded balance, indicates the balance sensor mechanical damage.
5. All repairs must be performed by the authorized personnel.
6. To perform the repair contact the nearest service point.

Emergency messages:

Message	Reason	Recommendation
C-1 ... 6 (over 1min.)	autotest negative result	contact the service
<i>Err-b</i>	balance loaded during turning on	remove load from the balance
	balance sensor mechanical failure	contact the service
I	balance mechanical failure	contact the service
H	balance overload	remove load from the balance
	balance mechanical failure	contact the service
indicator does not work	balance unstable, base vibrations, air blows	place the balance in location, assuring the indications stability
	balance damage	contact the service
- - - - -	tare setting not finished	contact the service
- -	tare setting unsuccessful (too low load or B/G pressed)	zero the balance or pres B/G again
- -	zeroing with too high load	set the tare

Declaration of Conformity

PCE-GROUP Europe

*Im Langel 4
D – 59872 Meschede
E-Mail: info@warensortiment.de*

*Tel: 0049-[0]2903- 976 99-0
Fax: 0049-[0]2903-976 99-29
Internet: www.pce-group-europe.com*

Konformitätserklärung

**Declaration of conformity for apparatus with CE mark
Konformitätserklärung für Geräte mit CE-Zeichen
Déclaration de conformité pour appareils portant la marque CE
Declaración de conformidad para aparatos con disitintivo CE**

Dichiarazione di coformità per apparecchi contrassegnati con la marcatura CE

PCE-TP 1500

1. EN 55022 standard *Limits and methods of measurement of radio disturbance characteristics of information technology equipment* and IEC 61000-4-3 *Electromagnetic compatibility (EMC) - Part 4-3: Testing and measurement techniques - Radiated, radio-frequency, electromagnetic field immunity test* harmonized with the Council Directive 89/336/EEC (Electromagnetic compatibility directive).

Additional information:

Conformity evaluation for the Council Directive 89/336/EEC was carried out by Research

Laboratory of Electrotechnology Institute.

Date: 01.03.2006

Signature: _____



PCE-GROUP Europe OHG

Management

In this direction will find a vision of the measurement technique:
<http://www.industrial-needs.com/measuring-instruments.htm>

NOTE: "This instrument doesn't have ATEX protection, so it should not be used in potentially explosive atmospheres (powder, flammable gases)."