



Tursdale Technical Services Ltd
Unit N12B
Tursdale Business Park
Co. Durham
DH6 5PG
United Kingdom
Phone: +44 (0) 191 377 3398
Fax: +44 (0) 191 377 3357
info@tursdaletechnicalservices.co.uk
<http://www.industrial-needs.com/>

MANUAL PCE-VT 3000



1 General Descriptions

1.1. Basic working principle

PCE-VT 3000 uses piezoelectric acceleration transducer to convert vibration signal into electric signal. Then by analyzing input signal, results including RMS of velocity values, peak-peak value of displacement, peak values of acceleration or real-time spectral charts are displayed or printed out.

1.2. Application range

The vibration meter is designed to test conventional vibration, especially the vibration test in rotating and reciprocating machines. It can be used not only to test the acceleration, velocity, and displacement of vibration as well as rev (or inherent frequency), but also perform simple failure diagnosis.

The technical specifications of PCE-VT 3000 comply with the requirements of GB 13823.3. PCE-VT 3000 is widely used in machinery, power, metallurgy, automobile and other industrial fields.

1.3. Technical Specifications

- Measurement range
 - Acceleration: 0.1 m/s² – 392 m/s² (Peak)
 - Velocity: 0.01 – 80 cm/s (RMS)
 - Displacement: 0.001 – 10 mm (Peak – peak)
- The frequency range
 - Acceleration: 10Hz – 200 Hz, 10Hz – 500 Hz, 10Hz – 1KHz, 10Hz – 10KHz
 - Velocity: 10Hz – 1KHz
 - Displacement: 10Hz – 500 Hz
- Accuracy: ≤±5%
- Temperature range: 0℃ ~ 40℃
- Humidity range: ≤80%

1.4. Basic configuration and Optional accessories

- Basic configuration

| Title | Quantity |
|--------------------------------------|-----------------------|
| TV300 main body | 1 |
| 6V/800mA ~220V / 50Hz power adapters | 1(select one of them) |
| 6V/800mA ~110V / 50Hz power adapters | |
| Vibration transducer TSV-01 | 1 |
| Leather wrap | 1 |
| Package case | 1 |
| Manual | 1 |

- Optional accessories

| Title | Quantity |
|---|----------|
| Data Management software (with a cable) | 1 |
| Printer (with a cable) | 1 |
| Magnetic base | 1 |
| Probe groupware | 1 |
| Long needle | 1 |

- Optional accessories

| Title | Quantity |
|---|----------|
| Data Management software (with a cable) | 1 |
| Printer (with a cable) | 1 |
| Magnetic base | 1 |
| Probe groupware | 1 |
| Long needle | 1 |

1.5. Other parameters

- Display screen: LCD, 320×200 pixels, with LED backlight
- Battery's parameters: Li battery, work 20 hours continuously. Charging time 12 hours.
- Dimensions: 171mm×78.5mm×28 mm
- Weight: 230g

1.6. Features

- Three display modes: Common mode, Special mode and Spectrum mode
- The acceleration, velocity, displacement of vibration and rev (or inherent frequency) can be tested.
- The testing meter can display measurement values in status bar according to alarm limit and warning limit.
- Simple failure diagnosis: Automatically raise the alarm and require the spectrum testing mode when the measurement value is beyond the limit.
- If equipped with printer, measurement value and spectral charts can be printed out.
- Connecting with PC (with the software), updating and memory of data is available and as well as the drawing of trend chart.
- Memory function: It can store 25×62 measurement values and 25 spectral charts.
- Li battery is used: The battery can charge at anytime safely and it can work continuously for a long time after charging is finish.
- With LED backlight and auto-shutdown function.

2 Technical terms

1. Vibration: A rapid linear motion of object about an equilibrium position, like piston, tuning fork or motor.
2. Vibration displacement: The magnitude of a vector from the initial position to a subsequent position assumed by a body.
3. Vibration velocity: The rate of speed of vibration.
4. Vibration acceleration: The rate of change of vibration velocity with respect to time.
5. Vibration frequency: The number of complete cycles of vibration per unit time.
6. Point number: One point number correspond to one testing point, PCE-VT 3000 will keep up to 62 historical results for each point.
7. Patrol test: Test more than one point in a fixed routine. Each point correspond one testing point.
8. Warning limit: Remind users that the vibration is beyond the limit of the safe state.
9. Alarming limit: Remind users that the vibration is beyond the limit of the destruct status.
10. RMS, peak values and peak-peak values (see Figure 2-1)
11. Spectral chart: A chart indicates the magnitude distribution of each frequency in the whole vibration.

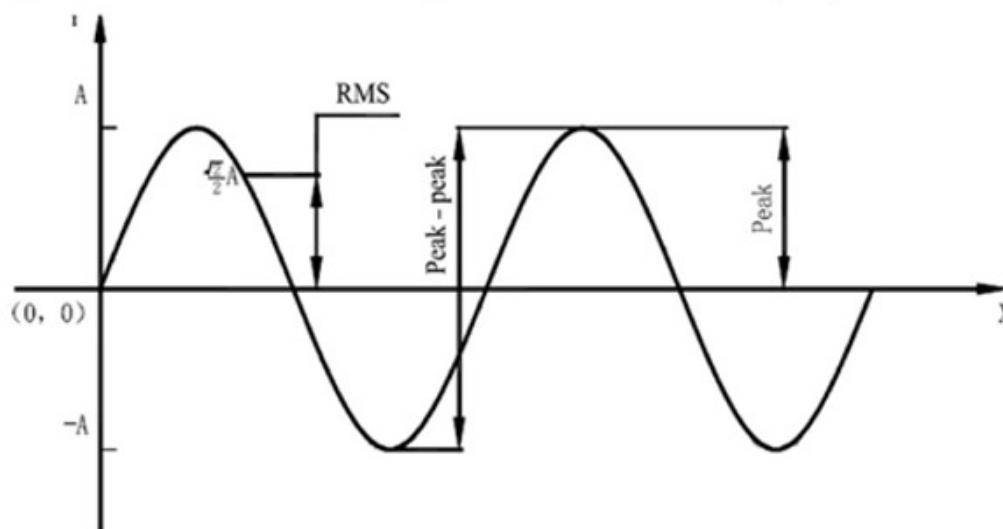

Figure 2-1

3 Configuration

3.1. Description of components

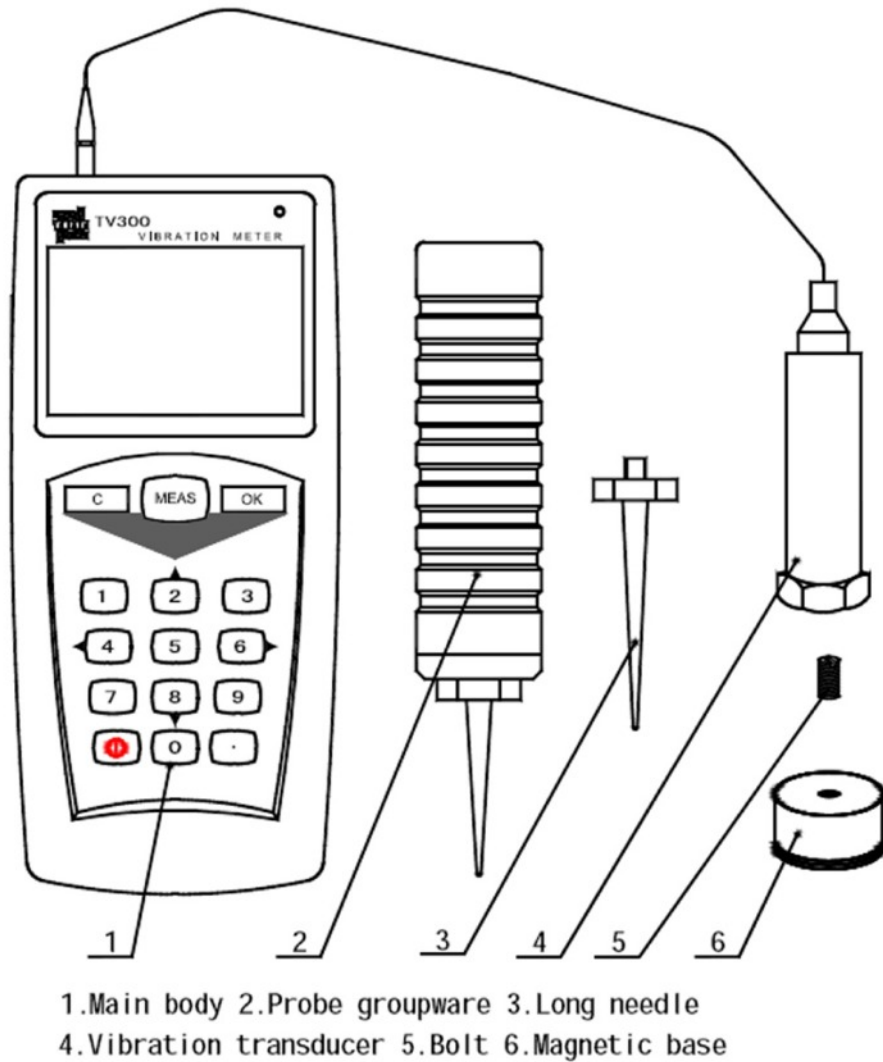

Figure 3-1

According to different situations, the transducers maybe fixed in the probe groupware or connected to the magnetic base (see chapter 4 in detail).

3.2. Appearance

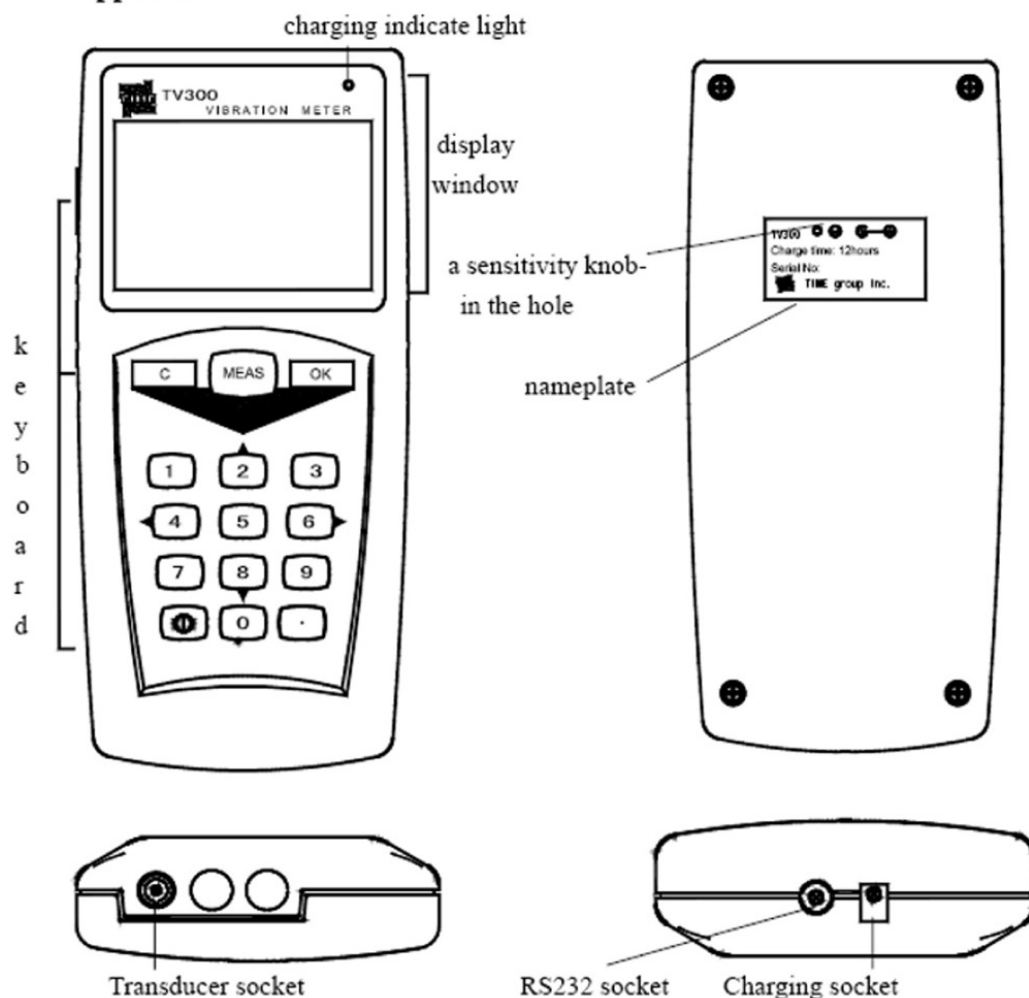
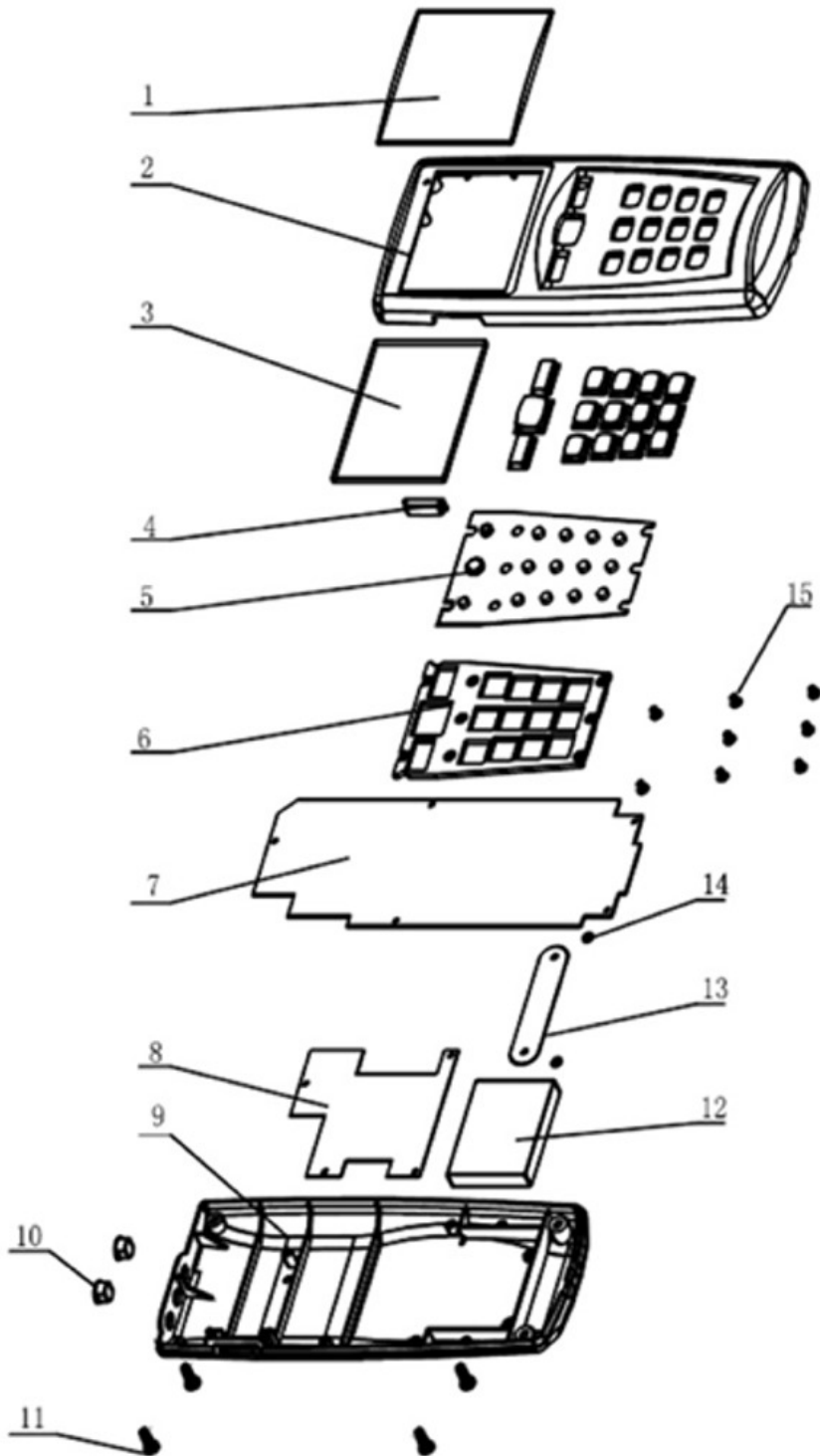

Figure 3-2

3.3. Description of main body

| Title | | | Title | | |
|-------|----------------|----|-------|----------------|----|
| 1 | Display screen | 1 | 9 | Back cover | 1 |
| 2 | Front cover | 1 | 10 | Hole cover | 2 |
| 3 | LCD | 1 | 11 | Bolt M3 | 4 |
| 4 | Keyboard | 16 | 12 | Li battery | 1 |
| 5 | Sealed tray | 1 | 13 | Battery holder | 1 |
| 6 | Plastic frame | 1 | 14 | Gasket M2 | 2 |
| 7 | Front PCB | 1 | 15 | Bolt M2 | 19 |
| 8 | Back PCB | 1 | | | |

The Structure of PCE-VT 3000 Vibration Meter



4 Installation of Transducer

4.1. Installation principle

- The testing position should show the vibration characters of the object to be tested.
- The main axis of the transducers should be consistent with the direction of the object to be tested.
- The transducers should be in close contact with the object to be tested

4.2. Install method

| Install method | Install with bolts | Install with magnetic base | Install with probe |
|-------------------------|--------------------|--|---|
| Cost | None | low | Rather high |
| Affection on the result | None | When roughness is worse than Ra1.6, the result maybe not stable. | When caring about acceleration and the vibration frequency is higher than 1KHz, the result will be smaller. |
| Convenience | Not good | good | Best |

4.2.1. Installed with bolt

Application range: Screw eye has no influence on the running of the object being tested.

Usage: Drill a screw eye 5mm deep in the object being tested. Connect the transducer to the object by bolts (see Figure 4-1). And this is the method that the frequency response is best.

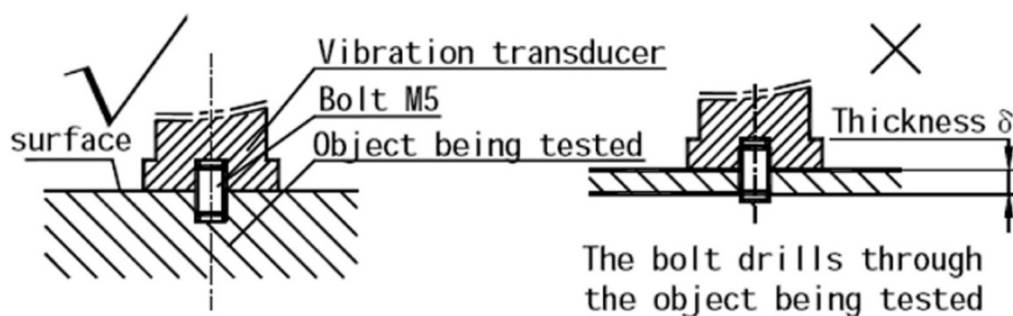

Figure 4-1

4.2.2. Installed with magnetic base

Application range: Magnetic, flat surface, roughness less than Ra1.6, acceleration less than 20 m/s^2 .

Usage: Before using, take off the iron wafer and rubber wafer under magnetic base (ensure enough suction), adsorbed on the object being tested and then screw up the magnetic base on transducer (see Figure 4-2). After usage, put back the iron wafer and rubber wafer to maintain the magnetism.

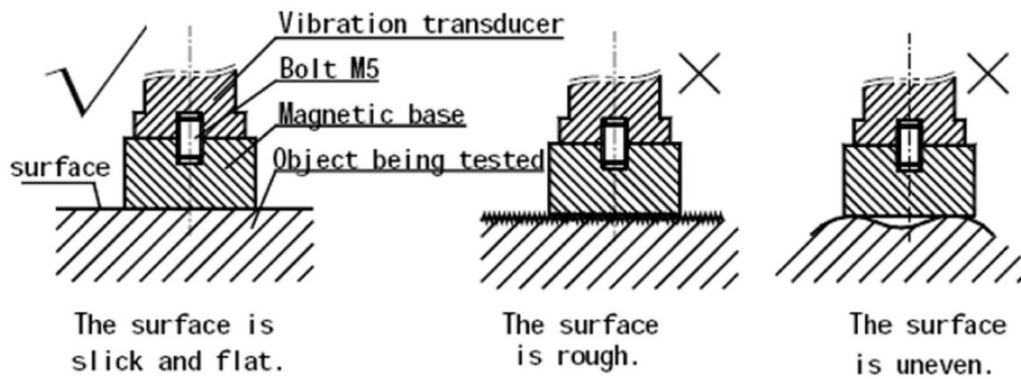

Figure 4-2

4.2.3. Installed with probe

Applications range: Frequency is less than 1KHz; vibration energy is not too small.

Usage: Connect the needle to the transducer directly by using probe groupware (see figure 4-3)

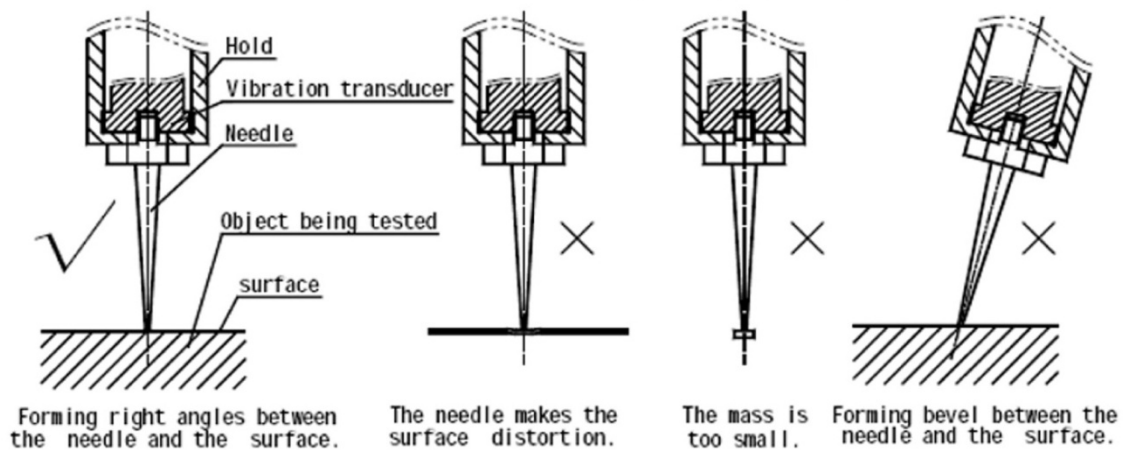

Figure 4-3

5 How to Use the Meter

5.1. Basic concept

Special display mode is as follows (see Figure 5-1).

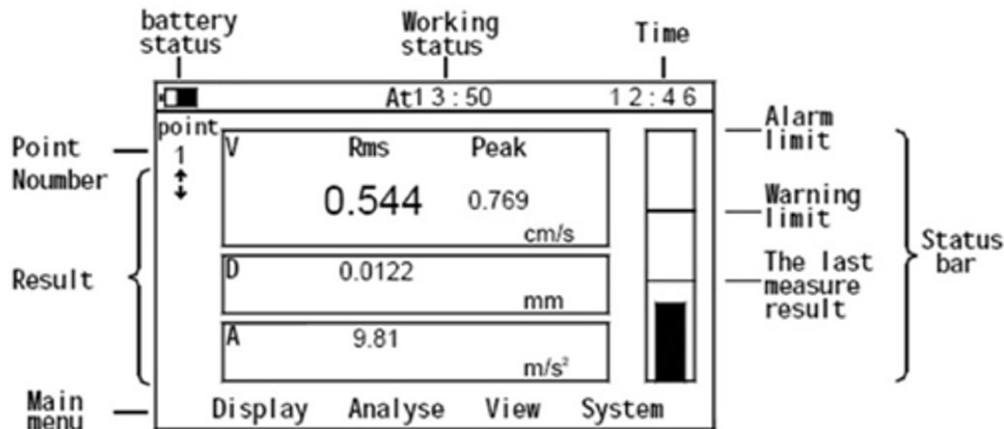





Figure 5-1

- Battery status: The full scale indicates the power is 100%.
- Working status: When the measurement goes on, displays one moving column. When the measurement is finished, displays "at hh : mm".
- Time: Current time.
- Measurement point number: One point number correspond to one testing point. PCE-VT 3000 will keep up to 62 historical results for each point.
- Measurement values: Indicate the testing results of the acceleration, velocity, and displacement.
- Status Bar: Indicate the relative relation of testing result, last testing result, warning limit and alarm limit.
- Main menu: Consist of display, analyse, view and system.

5.2. Simple test

- Press  key to power on → Press  key to start the testing operation (displays one moving column) → Press  key again to finish the test → Read the measurement values
- When testing continuously, the measurement point number can increase automatically. Users can also choose the measurement point number by Up/Down keys.

5.3. How to use the menu

The descriptions of the menu give as follows (adjust): (※ indicates the default settings).

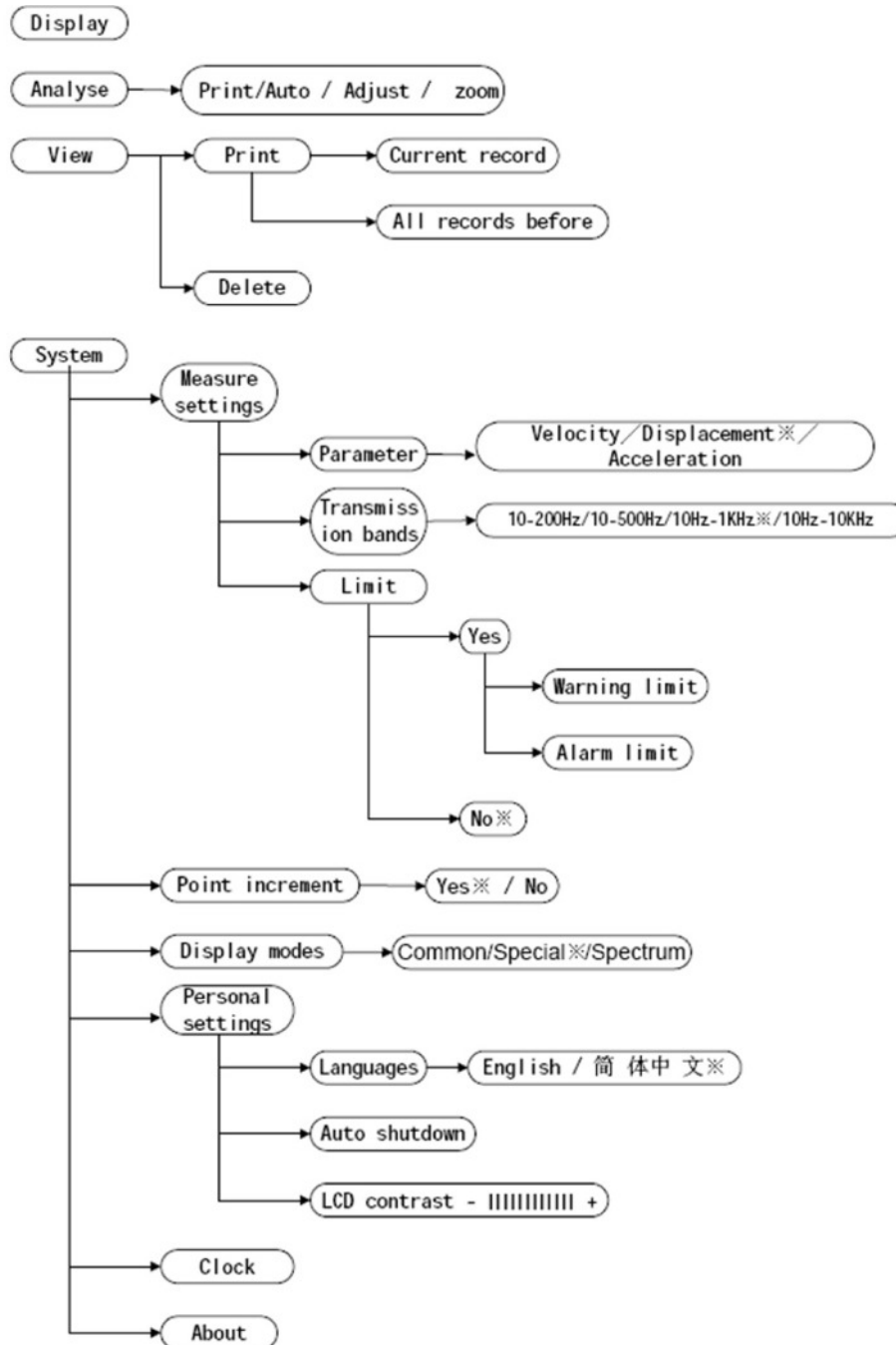

Left/Right keys are used to choose in the rows of the menu. Up/Down keys are used to choose in the columns of the menu. The background color of the fonts in the menu changing to black indicates the item is chosen.

Press key to confirm the operation or enter into the submenu, Press to cancel operation or return to upper menu. Up, Down, Left, Right keys and Number 2,4,6,8 keys are used alternately. When operation is on the menu, the direction keys are in use. When numbers are need, the number keys are available.

5.4. Description of functions

5.4.1. Display

“Display” can change the display modes from common, special and spectrum modes. It can give convenience for users to look through the data from different way, but it does not change the default settings of display modes. If users want to change the default settings of display modes, the submenu “Display modes” in the menu “System” should be changed.

5.4.2. Analyse

When diagnosing the fault, users could use this function. Spectrum chart maybe display like this. (See Figure 5-2)

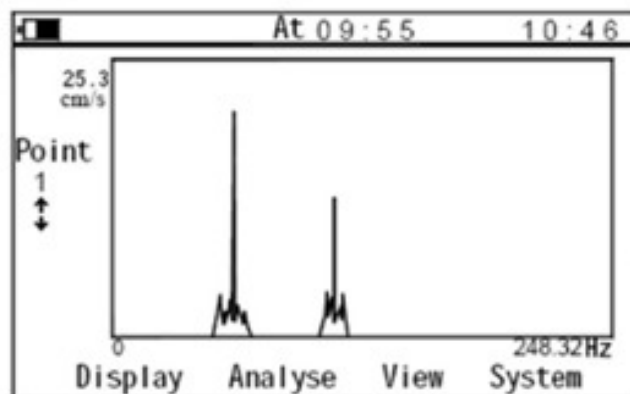

Figure 5-2

When the measurement value is higher than the warning limit, PCE-VT 3000 can automatically give an alarm and request to enter into spectrum testing mode (see Figure 5-3).

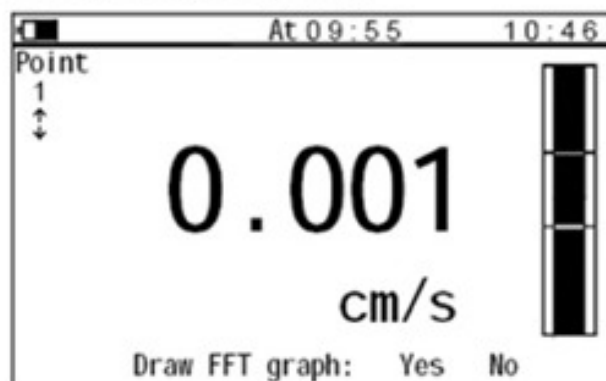
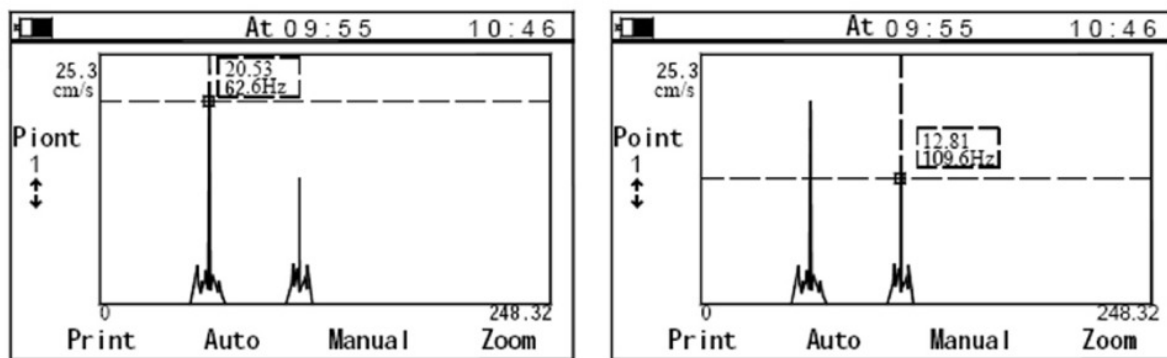

Figure 5-3

The “Analyse” menu consists of “Print”, “Auto”, “Adjust” and “Zoom” four sub items.

- Print: Print out current spectral charts.
- Auto:

Peak values of the spectral chart could be automatically captured. And different peak values could be selected by Left/Right keys. (see Figure 5-4)



(a)

(b)

Figure 5-4

Figure (a) shows the peak-peak value tested is 62.6Hz, that maybe the rev of the tested object;

Figure (b) shows the peak value tested is 109.6Hz, that maybe the inherent frequency of the tested object;

- Manual

The values of different points in the charts can be looked through in the manual style. The cursor position can be adjusted by Left/Right keys. The amplitude and frequency of the point, which the cursor indicates, can be displayed. (see Figure 5-5).

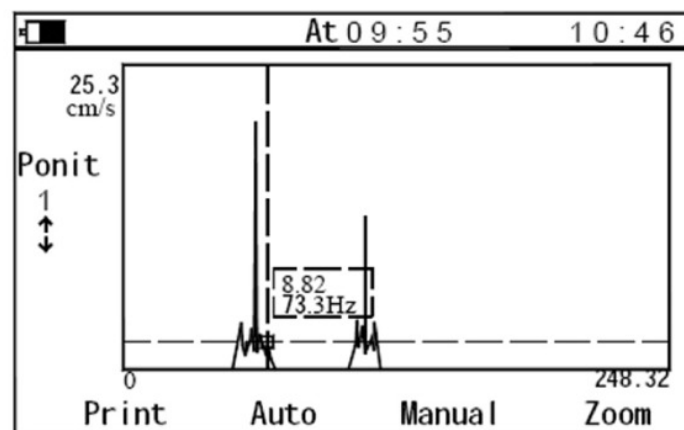

Figure 5-5

- Zoom

In spectrum analysis, the spectrum zoom function can change the frequency resolution in the range selected by users. Firstly, to select the range of the frequency---that is the concerned area, press Left/Right keys to move the cursor. The cursor could move more quickly when the Left or Right key is hold. Secondly, Up/Down keys could change the frequency resolution. The resolution could reach 0.25Hz.

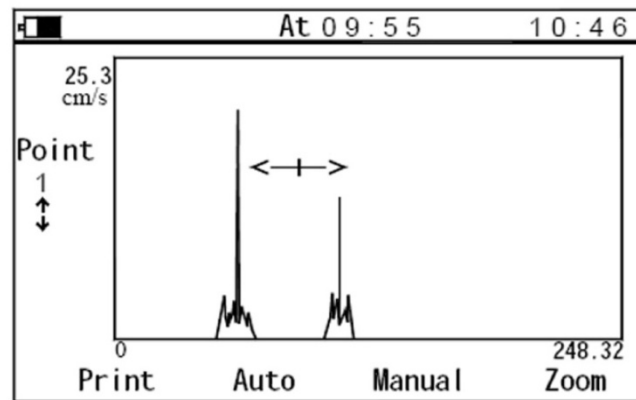

Figure 5-6

5.4.3. View

Users can look through the measurement results stored in the memory by selecting “View”. The information of each measurement result comprises point number, testing time and certain results (see Figure 5-7). Users could print out the list. Also, the data can be deleted.

| | | | | | 1 2 : 4 6 |
|----|--------|-------|-------|-------|-----------|
| | | | | | Point |
| Δ | | | | | 1 |
| 1. | 13: 50 | 01/10 | 0.544 | cm/s | |
| 2. | 13: 49 | 01/10 | 0.249 | cm/s | |
| 3. | 11: 07 | 01/10 | 0.239 | cm/s | |
| 4. | 11: 06 | 01/10 | 0.250 | cm/s | |
| 5. | 11: 06 | 01/10 | 0.205 | cm/s | |
| | | | | Print | Delete |

Figure 5-7

5.4.4. System

5.4.4.1. Measurement settings

- Parameter: Velocity, Displacement and Acceleration. Affection of this setting is shown in 5.4.4.3.
- Transmission bands: According to application, select the bands of frequency.
- Limit: When the limit is set, the meter could display status bar to inspect the status of the running equipment easily. As soon as the tested value is beyond the limit, the meter request to enter into diagnosis (see Figure 5-2).

5.4.4.2. Point increment

If select “Yes”, when a testing operation of the current point number is finished, the point number will increase automatically, and go into the waiting state of the next point number. Up/Down keys can also change the testing point number.

If select “No”, point number will not increase automatically. When tests are performed continuously, the measurement results will be regarded as different testing results of the same testing point number.

5.4.4.3. Display modes

There are three display modes: Common mode (Table 5-1, Figure 5-8), Special mode (Table 5-2, Figure 5-9) and Spectrum mode (Figure 5-2).

Table 5-1 Common mode

| | | | |
|--------------------|-----------------|-----------------------------------|----------------------------|
| Selected parameter | velocity | displacement | acceleration |
| Display area | RMS of velocity | peak – peak value of displacement | peak value of acceleration |

Table 5-2 Special mode

| Display area / Selected parameter | Display area 1 (left) | Display area 1 (right) | Display area 2 | Display area 3 |
|-----------------------------------|-----------------------------------|------------------------|-----------------------------------|-----------------------------------|
| Velocity | RMS of velocity | peak value of velocity | peak – peak value of displacement | peak value of acceleration |
| displacement | peak – peak value of displacement | RMS of displacement | RMS of velocity | peak value of acceleration |
| acceleration | peak value of acceleration | RMS of acceleration | RMS of velocity | peak – peak value of displacement |

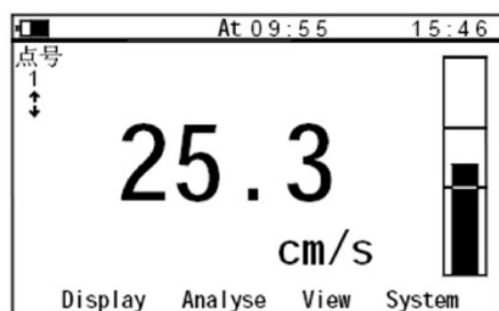

Figure 5-8 Velocity-common

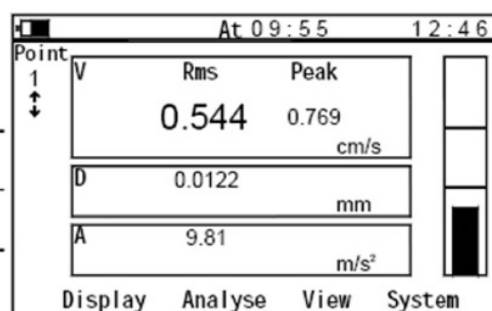

Figure 5-9 Velocity- special

5.4.4.4. Personal settings

- Languages: There are two languages available: Chinese and English.
- Auto shutdown: The meter will shutdown automatically if there is no operation for a while. And users can set the delay time themselves.
- LCD contrast: Users can adjust LCD contrast by Left/Right keys.

5.4.4.5. Time

Time is the assistant information of the measurement results. PCE-VT 3000 can automatically record the time when the test is performed. If the time is not correct, it should be reset manually.

5.4.4.6. Software information

It consists of the model of the meter and the software identifier.

6 How to use the accessories

PCE-VT 3000 has accessories such as printer and corresponding software. If equipped with printer, the printing operation can be performed. The data stored in PCE-VT 3000 can be uploading to PC and do analysis with corresponding software. If PC is equipped with printer, the data can also be printed out from PC.

PCE-VT 3000 connects to printer or PC through a communication cable. One end is connected to PCE-VT 3000 through RS232 serial port, and the other end is connected to printer or PC through a 9-pin connector.

How to use the software can refer to the specifications of the corresponding software.

7 Trouble shooting

- When the battery cannot charge, check the charging indicating light.
- The measurement value is unstable.
 1. Make sure the vibration frequency of the vibration object is in the frequency range of 10Hz—10kHz.
 2. If the magnetic base is used, pay attention to:
 - a. Make sure the surface of the tested object is flat, and roughness is smaller than Ra1.6.
 - b. Make sure the iron wafer below the magnetic base is taken off, and the magnetic force is enough.
- When enter the non-mother language system because of incorrect operation, users can change back the mother language referring to the construction of the menu (see 5.3).

If some trouble cannot be overcome, please contact to TIME Group Inc.

8 Maintenance

1. Operating environment: Strictly avoid collision, heavy dust, dampness, strong magnetic field, oil, grease and dirt.
2. How to clean the main body of the meter: Because alcohol and other chemical liquid can erode the main body of PCE-VT 3000, especial the display window, little water can be used to clean to meter smoothly.
3. How to use the connector: Don't plug the connector of the transducers, printer or PC, when PCE-VT 3000 is power on.
4. Calibration: The vibration meter is a high-precision instrument and the environment will influence on it. So it should be calibrated periodically (half a year or one year). If the sensitivity has changed, it can be adjusted by rotating the knob which is use to adjust the sensitivity.
5. Electromagnetic influence: when the electromagnetic field is over 10 V/m, the accuracy of testing will be influenced.

9. Non-warranty Parts

Appendix 1: Vibration standard

a. Rank of machine vibration (ISO2372)

| Vibration amplitude Vibration Velocity V_{rms} (mm/s) | Machine sort | | | |
|---|--------------|----|-----|----|
| | I | II | III | IV |
| 0~0.28 | A | A | A | A |
| 0.28~0.45 | | | | |
| 0.45~0.71 | | | | |
| 0.71~1.12 | B | B | B | B |
| 1.12~1.8 | | | | |
| 1.8~2.8 | C | C | C | C |
| 2.8~4.5 | | | | |
| 4.5~7.1 | D | D | D | D |
| 7.1~11.2 | | | | |
| 11.2~18 | | | | |
| 18~28 | | | | |
| 28~45 | | | | |
| >45 | | | | |

Note: (1) Class I is small motor (power less than 15kW). Class II is medium motor (power between 15kW~75kW). Class III is high power motor (hard base); Class IV is high power motor (stretch base).

(2) A, B, C, D are vibration rank. "A" means good, "B" means satisfying, "C" means not satisfying, "D" means forbidden. Vibration velocity should be taken from the three perpendicular axes on the motor shell.

b. Maximum vibration of motor that power larger than 1 horsepower (NEMA MG1-12.05)

| Rev (rpm) | Displacement (p-p)(um) |
|-----------|------------------------|
| 3000~4000 | 25.4 |
| 1500~2999 | 38.1 |
| 1000~1499 | 50.8 |
| ≤999 | 63.6 |

* For AC motor, rev is maximum synchronous rev. For DC motor, it is maximum power rev. For motor in series, it is work rev.

c. Maximum vibration of high-power induction drive motor (NEMA MG1-20.52)

| Rev (rpm) | Vibration displacement (p-p)(um) |
|-----------|----------------------------------|
| ≥3000 | 25.4 |
| 1500~2999 | 50.8 |
| 1000~1499 | 63.6 |
| ≤999 | 76.2 |

*National Electric Manufacturers Association (NEMA) establishes two standards above.

d. Maximum vibration of squirrel-cage induction drive motor (API STD 541)

| Synchronous rev (rpm) | Vibration displacement (p-p)(um) | |
|--------------------------|----------------------------------|-----------|
| | Stretch base | Hard base |
| 720~1499 | 50.8 | 63.6 |

| | | |
|-----------|------|------|
| 1500~2999 | 38.1 | 50.8 |
| ≥3000 | 25.4 | 25.4 |

*American Petroleum Institute (API) established this standard.

e. ISO/IS2373 Motor quality standard according as vibration velocity.

| Quality rank | Rev (rpm) | H: High of shaft (mm) | | |
|---------------|-----------|--|-----------|-----------|
| | | Maximum vibration velocity (rms)(mm/s) | | |
| | | 80<H<132 | 132<H<225 | 225<H<400 |
| Normal (N) | 600~3600 | 1.8 | 2.8 | 4.5 |
| Good (R) | 600~1800 | 0.71 | 1.12 | 1.8 |
| | 1800~3600 | 1.12 | 1.8 | 2.8 |
| Excellent (S) | 600~1800 | 0.45 | 0.71 | 1.12 |
| | 1800~3600 | 0.71 | 1.12 | 1.8 |

Limit of rank "N" is suitable for common motor. When the request is higher than that in the table, limit can be gotten by dividing the limit of rank "S" with 1.6 or multiples of 1.6.

Appendix 2 Vibration frequency and possible reason

| Vibration frequency | Most possible reason | Other possible reason | Note |
|---|---|--|---|
| Synchronous with f_s * | Imbalance | 1) Eccentric of gear, belt sheave and bush 2) Shaft is not in the middle or curving (if vibration on the shaft direction is high), 3) Belt fault 4) Syntony 5) Reciprocate force | |
| Double f_s | Mechanical loose | 1) Shaft is not in the middle or curving (if vibration on the shaft direction is high), 2) Belt fault 3) Syntony 4) Reciprocate force | |
| Triple f_s | Not in middle | | |
| N multiple of f_s | Gear fault, liquid force, mechanical loose, reciprocating force | 1) $N \times f_s$ (N is the tooth number of the fault gear). 2) $N \times f_s$ (N is the paddle number of the fault pump or fan) | If loose is worse, there maybe higher multiple frequency. |
| $< f_s$ | Oil film eddy turbulence | 1) Drive belt fault 2) Interferential vibration 3) Beat frequency | |
| Synchronous with power frequency | Armature fault | Electric fault such as rotor broken, rotor eccentric, three phase imbalance and air clearance not symmetry | |
| Double the power frequency | Torsional impulse | | Seldom |
| High frequency (not multiple of f_s) | Shaft is not lubricate | 1) Cavitations and turbulent flow 2) Frictional force | Amplitude and frequency of vibration are always not steady. |



In this direction will find a vision of the measurement technique:
<http://www.industrial-needs.com/measuring-instruments.htm>

NOTE: "This instrument doesn't have ATEX protection, so it should not be used in potentially explosive atmospheres (powder, flammable gases)."