

Manual

PCE-A420 cup vane anemometer



Version 1.0
17.10.2014

Content

1	Introduction	3
2	Safety	3
3	Specifications	3
3.1	Features.....	3
3.2	General Specifications	4
3.3	Electrical Specifications (23 ±5°C).....	4
4	System description	5
5	Measuring Procedure	7
5.1	Wind Speed Measurement.....	7
5.1.1	Unit Change.....	7
5.1.2	Data Hold	7
5.1.3	Data Record (Max., Min. reading).....	7
5.2	Data Logger.....	8
5.2.1	Save data.....	8
5.2.2	Call Data	8
5.2.3	Delete Data (Empty the memory).....	9
6	Battery Replacement	10
7	Contact	10

1 Introduction

Thank you of purchasing a PCE-A420 cup vane anemometer from PCE Instruments.

A handy cup anemometer with digital display. The great advantage of the cup anemometer is no doubt in the possibility that you do not have to hold the cup anemometer exactly in the wind direction. Normal vane anemometers have the disadvantage that they only measure exactly when the impeller is held in the wind direction. The very smooth cup anemometer already responds to small flow rates.

2 Safety

Please, read this user's handbook carefully and completely, before you put it into service for the first time. The usage of the device may take place only through carefully trained staff.

- The device may only be used in approved temperature range
- The opening of the case should only be done by qualified personnel of the PCE Instruments.
- The instrument should never be placed with the user interface (e.g. keyboard side on a table)
- You should not make technical changes on the device
- The appliance should only be cleaned with a damp cloth / use only pH-neutral cleaner

This user's handbook is published from PCE Instruments without any guarantee.

We expressly point to our general guarantee terms, they can be found in our general terms of business.

If you have any questions please contact PCE Instruments.

3 Specifications

3.1 Features

- Cup vane anemometer, available for wind speed measurement, high reliability.
- Measurement range: 0.9 to 35.0 m/s
- Unit: m/s, km/h, ft/min, knot, mile/h.
- LCD display.
- IP 65, water resistance.
- Microprocessor circuit ensures high accuracy and provides special functions and features.
- Records Maximum and Minimum readings with recall
- 100 point data logger with recall
- Data hold.
- Auto power off saves battery life.
- Operates from DC 1.5V (UM4/AAA) x 4 PCs batteries.
- Low-friction ball vane wheels is accurate in both high and low velocities.
- Durable, long-lasting components, enclosed in strong, compact ABS-plastic housing.

3.2 General Specifications

Display	LCD size: 28mm x 19mm.
Measurement Unit	m/S (meters per second) km/h (kilometers per hour) Knot (nautical miles per hour) ft/min (feet per minute) mile/h (miles per hour)
Circuit	Custom one-chip of microprocessor LSI circuit.
Data Logger	Max. can save 100 point data with recall. Manual, push the data logger button once will save data one time.
Sensor Structure	Cup van probe with low friction ball bearing design.
Data Hold	Freeze the display reading.
Memory Recall	Maximum & Minimum value.
Sampling Time of display	Approx. 1 second.
Power Off	Auto shut off saves battery life or manual off by push button
Operating Temperature	0 to 50 °C.
Operating Humidity	Less than 80% R.H.
Power Supply	DC 1.5 V battery (UM4/AAA) x 4 PCs,
Power current	Approx. DC 6.8 mA
Weight	181g
Dimension	Main instrument: 190 x 40 x 32 mm (7.5" x 1.6" x1.3") Cup vane (3 cups with arm) : 135 mm dia.
Accessories Included	Instruction manual.....1PC Carrying case.....1PC

3.3 Electrical Specifications (23 ±5°C)

Measurement	Range	Resolution	Accuracy @reading
m/S	0.9 – 35.0 m/S	0.1m/S	± (2%+0.2 m/S)
Km/h	2.5 – 126.0 Km/h	0.1 Km/h	± (2%+0.8Km/h)
Knot	1.4 – 68.0 Knots	0.1 Knots	± (2%+0.4 Knots)
Ft/min	144 – 6895 Ft/min	1 Ft/min	± (2%+40 Ft/min)
Mile/h	1.6 – 78.2 Mile/h	0.1 Mile/h	± (2%+0.4 Mile/h)

4 System description

Front Panel Description

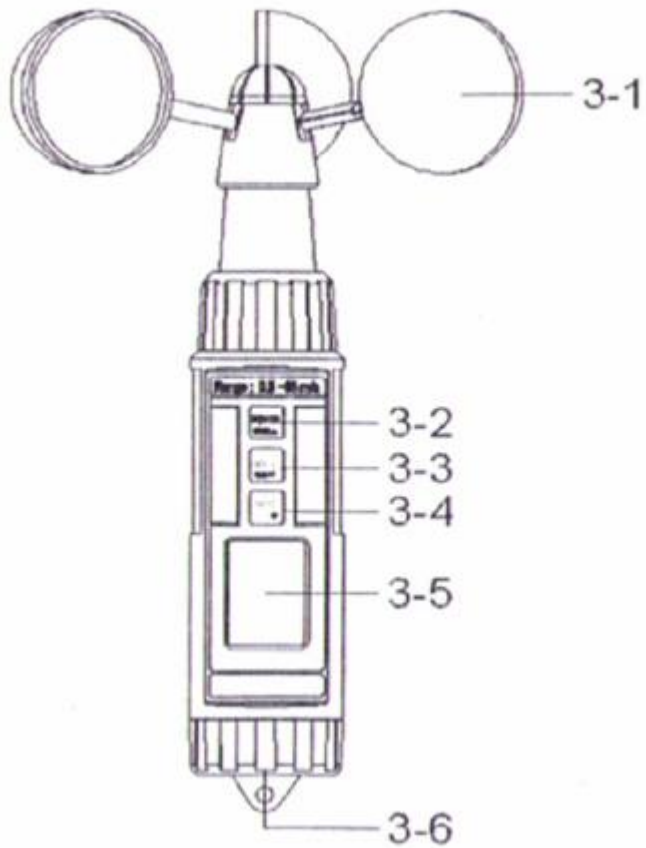

- 3-1 Cup Vane
- 3-2 Power (Logger ▲) Button
- 3-3 Hold (Unit ←) Button
- 3-4 REC (▼) Button
- 3-5 LCD Display**
- 3-6 Battery Compartment/Cover**

Install the Vane Cup

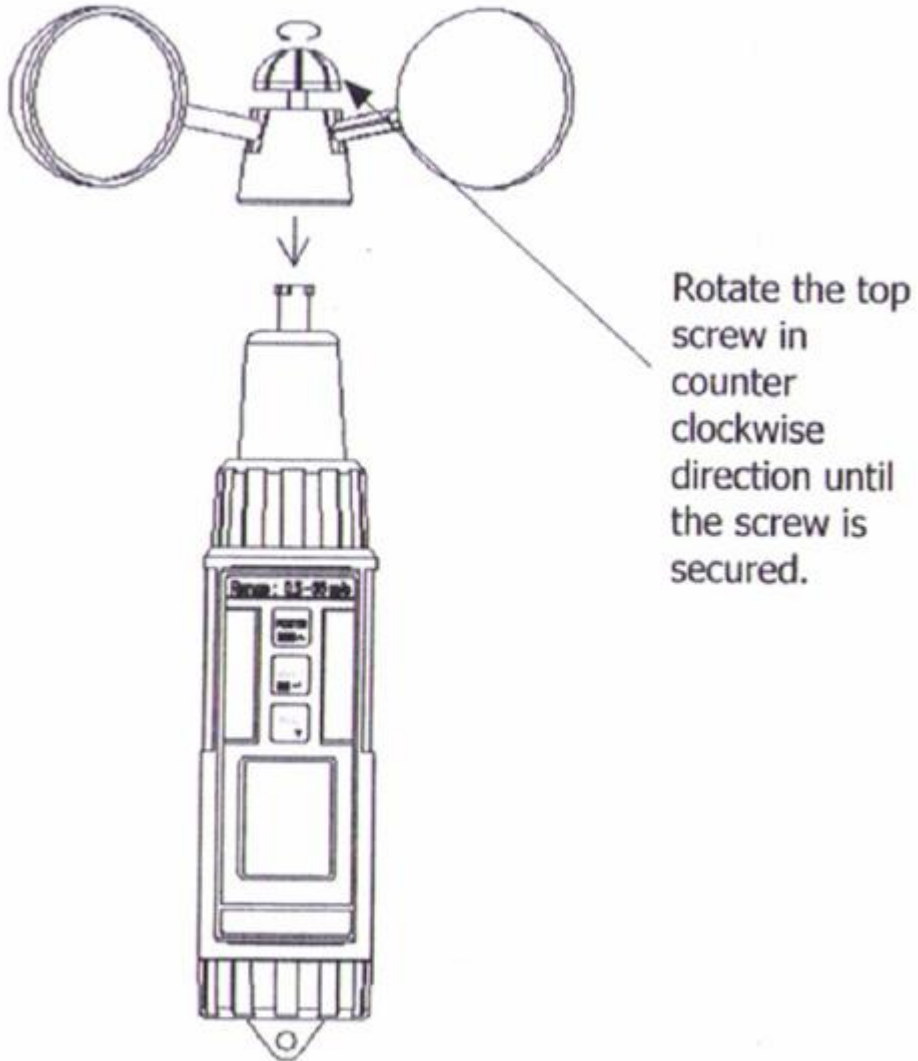

5 Measuring Procedure

5.1 Wind Speed Measurement

Turn on the meter by pressing the “Power Button” (3-2, Fig. 1) momentarily. Pressing the “Power- Button” (3-2, Fig. 1) momentarily again **to** turn off the meter.

- 1) Use the hand to hold the meter vertically. The “Cup Vane” (3-1) will be rotated and shows the measured the wind speed value on the “LCD Display” (3-5, Fig. 1).

5.1.1 Unit Change

- 1) Meter defaults unit value is “m/s”. Meter unit value can be changed to “m/s, km/h, knot, ft/min, mile/h
- 2) The method to change the unit: Press the “Unit Button” (3-3, Fig. 1) continuously, after several seconds the unit will change from m/s, km/h, knot, ft/min, mile/h” in sequence. When the desired unit is reached, release the finger from the “Unit Button” (3-3, Fig. 1), the new unit will be saved into the memory circuit and will be shown when the device is turned on again.

* When the display shows “HOLD” (refer 5-3) or “REC” (refer 5-4), the unit cannot be changed.

5.1.2 Data Hold

- During the measurement, press the “Hold Button” (3-3, Fig.1) momentarily to hold the measured value. The LCD will show a “HOLD” symbol.
- Press the “Hold Button” once again to release the data hold function.

5.1.3 Data Record (Max., Min. reading)

- 1) The data record function records the maximum and minimum readings. Press the “REC Button” (3-4, Fig.1) momentarily to start the data record function, the display shows “REC”.
- 2) With the “REC” symbol on the display.
 - a) Press the “REC Button” (3-4, Fig.1) momentarily again, the “REC MAX” symbol along with the maximum value will appear on the display.
 - b) Press the “REC Button” (3-4, Fig.1) momentarily again, the “REC MIN” symbol along with the minimum value will appear on the display.

* When display shows “REC MAX” or “REC MIN”, press the “Hold Button” (3-3, Fig.1) momentarily, this will delete the max. (min.) value, the display will show the “REC.” only and execute the memory function continuously.

- c) To exit the memory record function, press the “REC” button for 2 seconds at least. The display will revert to the current reading, and will not to show “REC”.

5.2 Data Logger

The meter can save max. 100 point data into the memory circuit

5.2.1 Save data

- 1) Turn on the meter.
- 2) Press the "REC Button" (3-4, Fig.1) momentarily, shows "REC" on the display.
- 3) Press the "Logger Button" (3-2, Fig.1) momentarily will save one measuring value to memory, display will show:

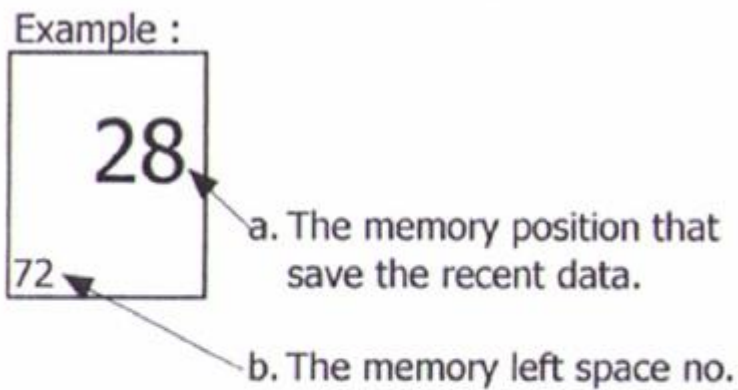

c. $a + b = 100$
 For example : $28 + 72 = 100$

- 4) To exit the memory data logger (record) function, press the "REC" button for 2 seconds at least. The display will revert to the current reading, and will not show "REC".

5.2.2 Call Data

- 1) Turn on the meter. Press the "Hold Button" (3-3, Fig.1) momentarily, LCD shows "HOLD". Following, press the "REC Button" (3-4, Fig.1) momentarily, display shows:

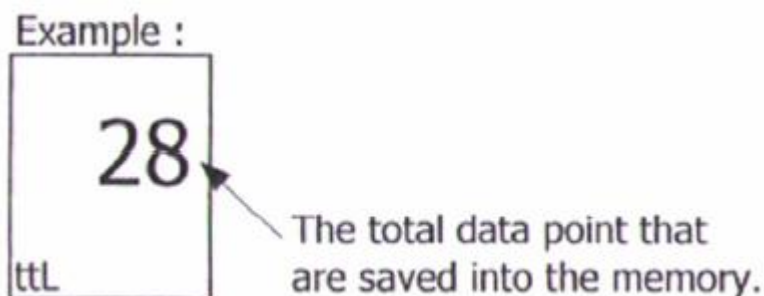

Uses "▲ Button" (3-2, Fig.1) or "▼ Button" (3-4, Fig.1) to call the data **what are** already saved into the memory.

Note:

* During call the data, the unit display will be flashed.

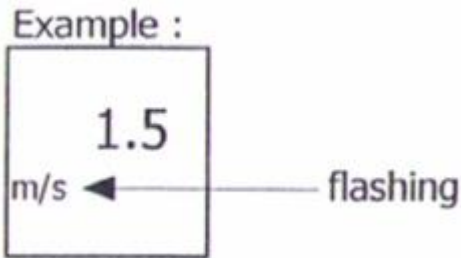

* Press “Hold Button” (3-3, Fig.1) will exit the data call function.

5.2.3 Delete Data (Empty the memory)

- 1) Turn off the meter first.
- 2) Press the “REC Button” (3-4, Fig.1) continuously and do not release, at the same time press the “Power Button” (3-2, Fig.1) momentarily, the display will show following screen, then release both fingers from the buttons.

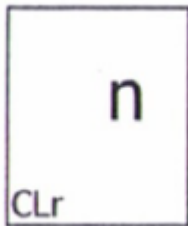

Press “▼ Button” momentarily, display shows:

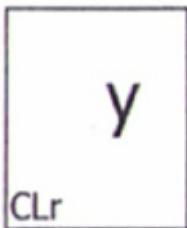

Press “← Button” (3-3, Fig.1) momentarily, the display shows:



Now all saved data's are deleted, memory is empty.

6 Battery Replacement

- Replace the batteries when the left corner of the LCD displays shows the low battery icon “”, using 4 fresh 1.5V (UM4, AAA) batteries.
- To change the batteries, open (rotate clockwise direction) the “Battery Cover” (3-6, Fig.1).
- Make sure the “Battery Cover” (3-6, Fig.1) is secured after changing the batteries.

7 Contact

If you have any questions about our range of products or measuring instruments please contact PCE Instruments UK Ltd.

By post:

PCE Instruments UK Ltd.
Units 12/13 Southpoint Business Park
Ensign Way, Southampton
Hampshire

United Kingdom, SO31 4RF

By phone:

Support: 02380 987 035

Sales: 02380 987 030

You can find an overview of our measuring instruments here: <http://www.industrial-needs.com/measuring-instruments.htm>

You can find an overview of our scales here <http://www.industrial-needs.com/balances.htm>

